

Mentor Storybook Bench Project

Transform a Fiberglass Book Bench into Vibrant Art!

Artist Application Packet

Concept and Theme

Transform a fiberglass book bench into a captivating piece of art while capturing the essence of storytelling!

These one-of-a-kind story book benches will be placed outdoors at Springbrook Gardens Park June through August 2025 for the enjoyment of the public.

By bringing your creative vision to life, the fiberglass book bench will be a delightful addition to the park and serve as a testament to the power of imagination and storytelling.



Suggested Design Elements

- **Storybook Characters:** Choose a book from the PBS Great American Read 100 book list (attached). Iconic characters from beloved books could be subtly integrated into the design, peeking out from the pages of the bench.
- **Literary Quotes:** Quotes could be included along the edges of the bench.
- **Vibrant Colors:** Adorn the book benches with a palette of bright and inviting colors to attract attention and evoke curiosity.
- **Sealing and Finishing:** A protective sealant will be provided to the artist that once applied will maintain the integrity of the artwork, protecting it from the elements and ensuring longevity.

Benefits of Participation

- **Showcase Talent:** Displaying artwork at such a prominent location provides an excellent platform to showcase the artist's skills.
- **Increased Exposure:** Springbrook Gardens Park is among the most popular parks in our system which will result in high visibility of the selected pieces.
- **Media and Social Media Attention:** The project will receive coverage in local media, enhancing the artist's profile and reaching new audiences through social media platforms.
- **Networking Opportunities:** The gala book bench auction on August 20, 2025, offers a chance to connect with other artists, art enthusiasts, and potential patrons.
- **Monetary and Experience Rewards:** An honorarium of \$500 and a ticket to the gala provide both financial and experiential benefits, making participation rewarding on multiple levels.

How to Apply

- Five applications will be chosen for production.
- Complete and submit application form along with \$40.00 nonrefundable application fee, proposed design, resumes, and work samples.
- Please complete your proposed designs in full color using the provided templates. Please do not submit designs larger than a standard 8.5" x 11" piece of paper.
- Your application must be accompanied with a resume, and/or printed samples of your work.
- Submissions open to artists 18 and older who reside in Lake County, Ohio.
- All submissions must be received by Monday, March 17, 2025 at 4:00 PM.
- Send via email to Wildwood@cityofmentor.com or in hard copy form to Wildwood Cultural Center, ATTN: Story Book Bench Project, 8500 Civic Center Blvd., Mentor, Ohio. 44060. Checks payable to the City of Mentor.



For questions or additional information, contact Wildwood Cultural Center at 440-974-5735 or wildwood@cityofmentor.com.

Brought to you by the city of Mentor and the Mentor Community Arts Commission.

Mentor Storybook Bench Project

Transform a Fiberglass Book Bench into Vibrant Art!

Artist Application Packet

Criteria

- Originality of design concept (must be your own design).
- Submissions may not be exact replicas of existing book cover art. It is forbidden to duplicate copyrighted material.
- Clarity of design that clearly depicts book choice.
- Design must reflect imagery that is appropriate for all audiences.
- Designs that are religious, political, or sexual, in nature will not be accepted. Corporate logos and advertising are not permitted.
- The selection committee reserves the sole discretion to accept, or reject, any design.
- Designs cannot be changed from the initial proposal; if the Artist wishes to make changes, a new design specification must be submitted and approved.
- All submitted designs will be judged by members of the Community Arts Commission along with professional artists.
- Application fees are NOT refundable.
- Only 5 application submissions will be chosen for production. Selected artists will be notified of acceptance.
- Artists must meet all contractual obligations and adhere to the project timeline.
- Artists must send progress photos on a weekly basis to (potentially) be used in advertising.
- Artists must supply their own materials and paints.
- Selected artists will receive detailed instructions for the pickup and delivery of the book benches.
- Book benches measure 48" x 38" x 38" and weigh a total of 180 lbs. Primer white fiberglass laminated book with a permanent powder coated white steel plate base measuring 48" x 20" x .25".
- Artists will be given a gallon of sealant to apply to bench prior to submitting the final project.
- Book benches will be placed outdoors at Springbrook Gardens Park from June through August 2025.
- Artists should consider the weather and other elements, including sun, rain, wind, and dirt.
- Artists will receive a preliminary payment of \$100.00 for production materials. An additional \$400 will be paid upon delivery and approval of the finished sculpture.

Important Dates

- Deadline for submission is **Monday, March 17, 2025 at 4:00pm**
- Selected artists will be notified on or before **March 28, 2025**.
- Artists must pick up their bench from the Wildwood Cultural Center between **March 31 and April 4, 2025**.
- Artists must deliver completed benches on **May 12, 2025**, to Springbrook Gardens Park, 6776 Heisley Road, Mentor, OH 44060.
- Story Book Bench Project Gala will be held from 7:00 to 9:00pm on **August 20, 2025**, at Springbrook Gardens Park.

**The city of Mentor reserves the right to change project timeline as necessary.*

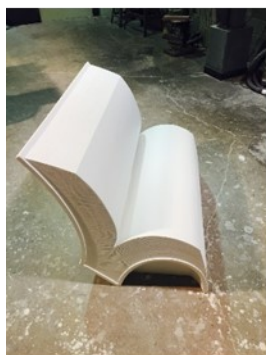

Front View

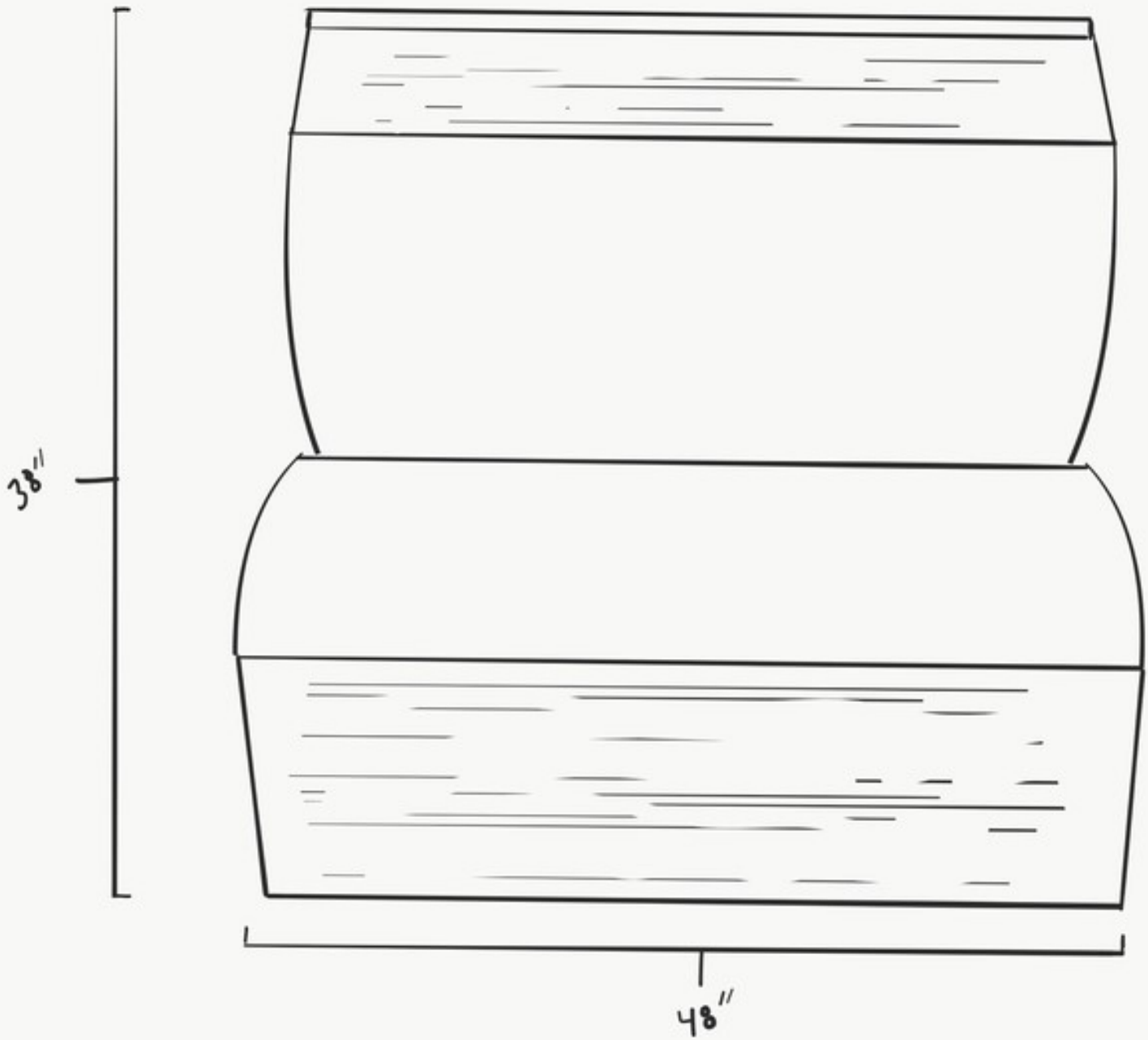

Back View

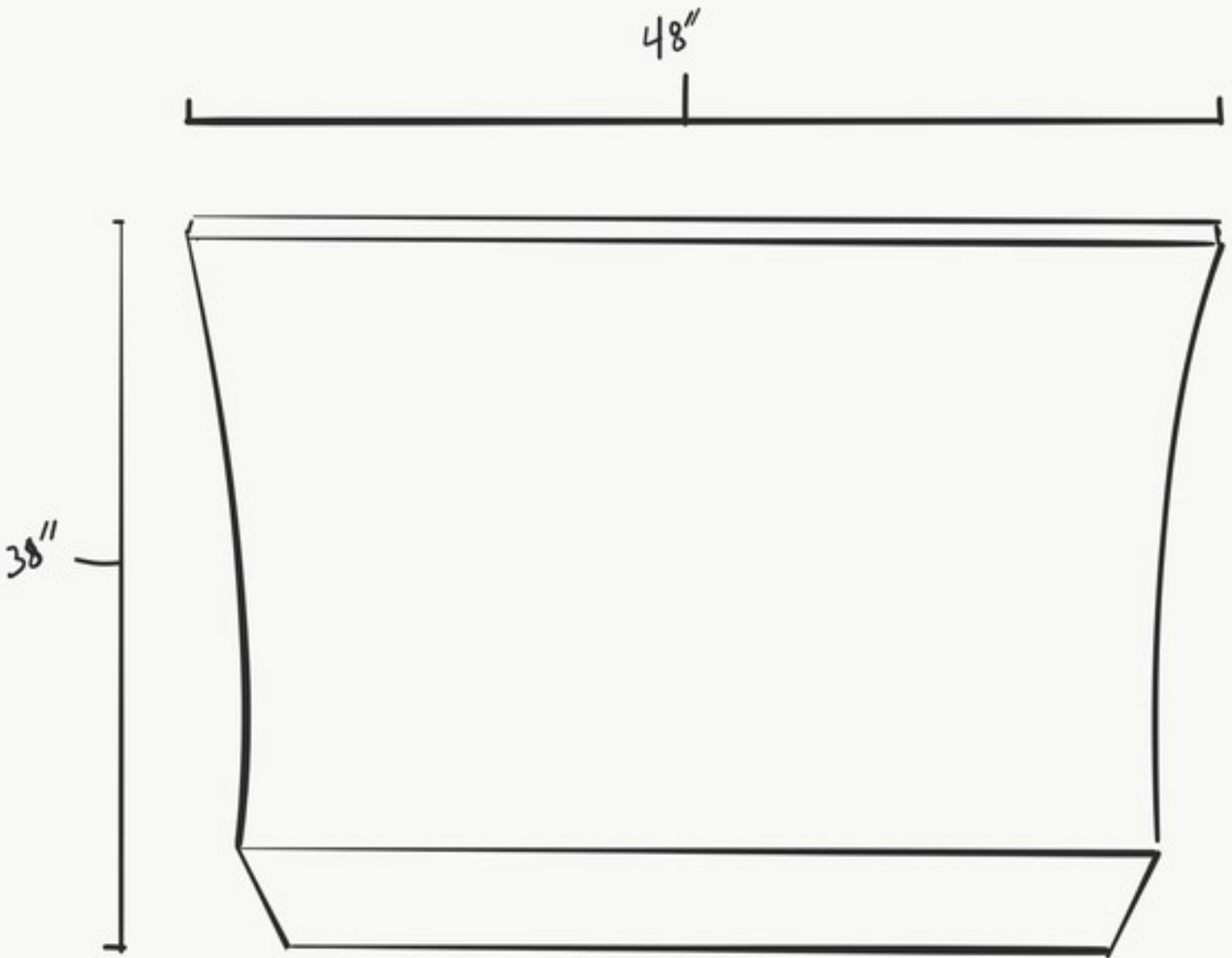

Left Side

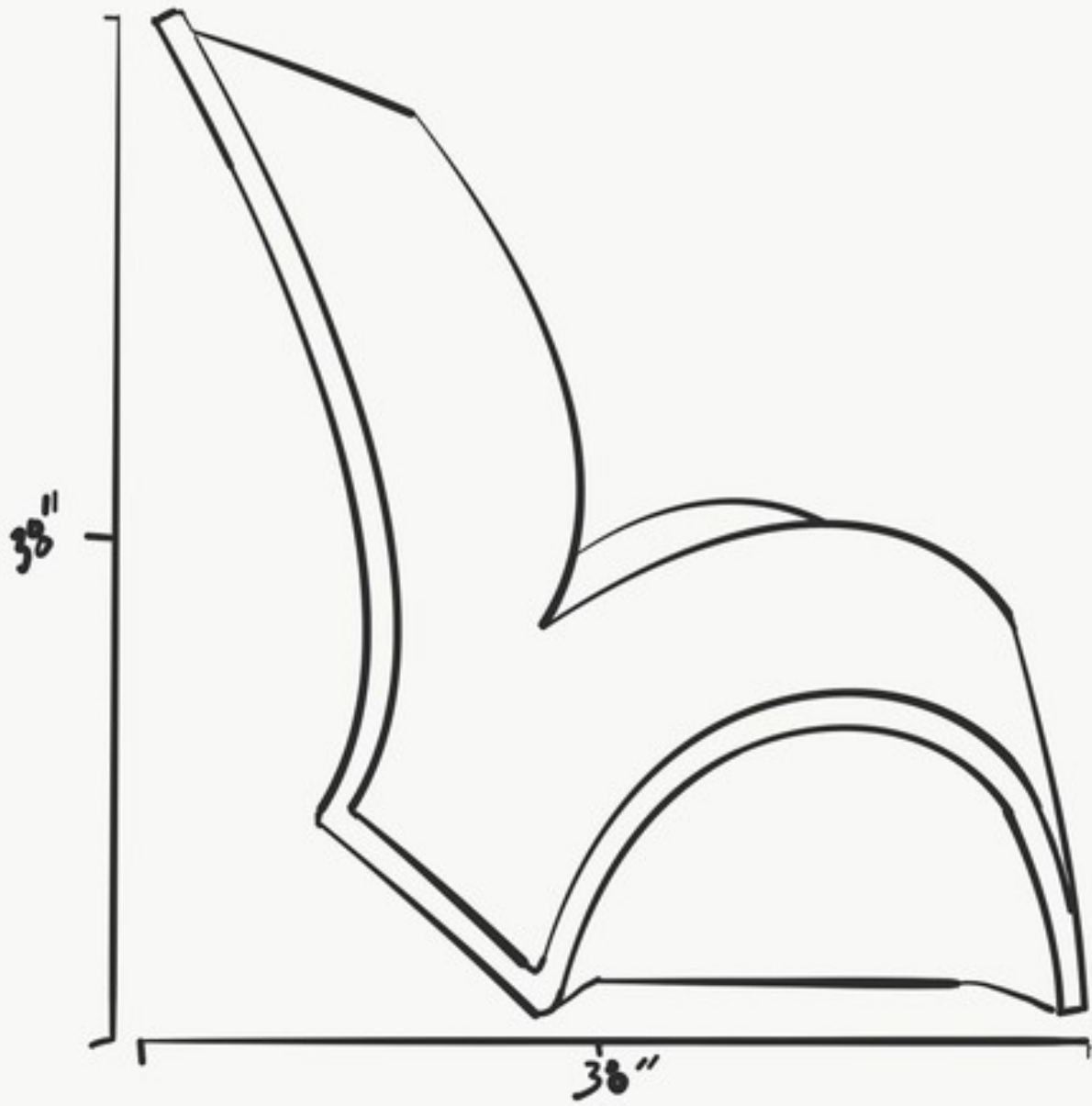

Right Side

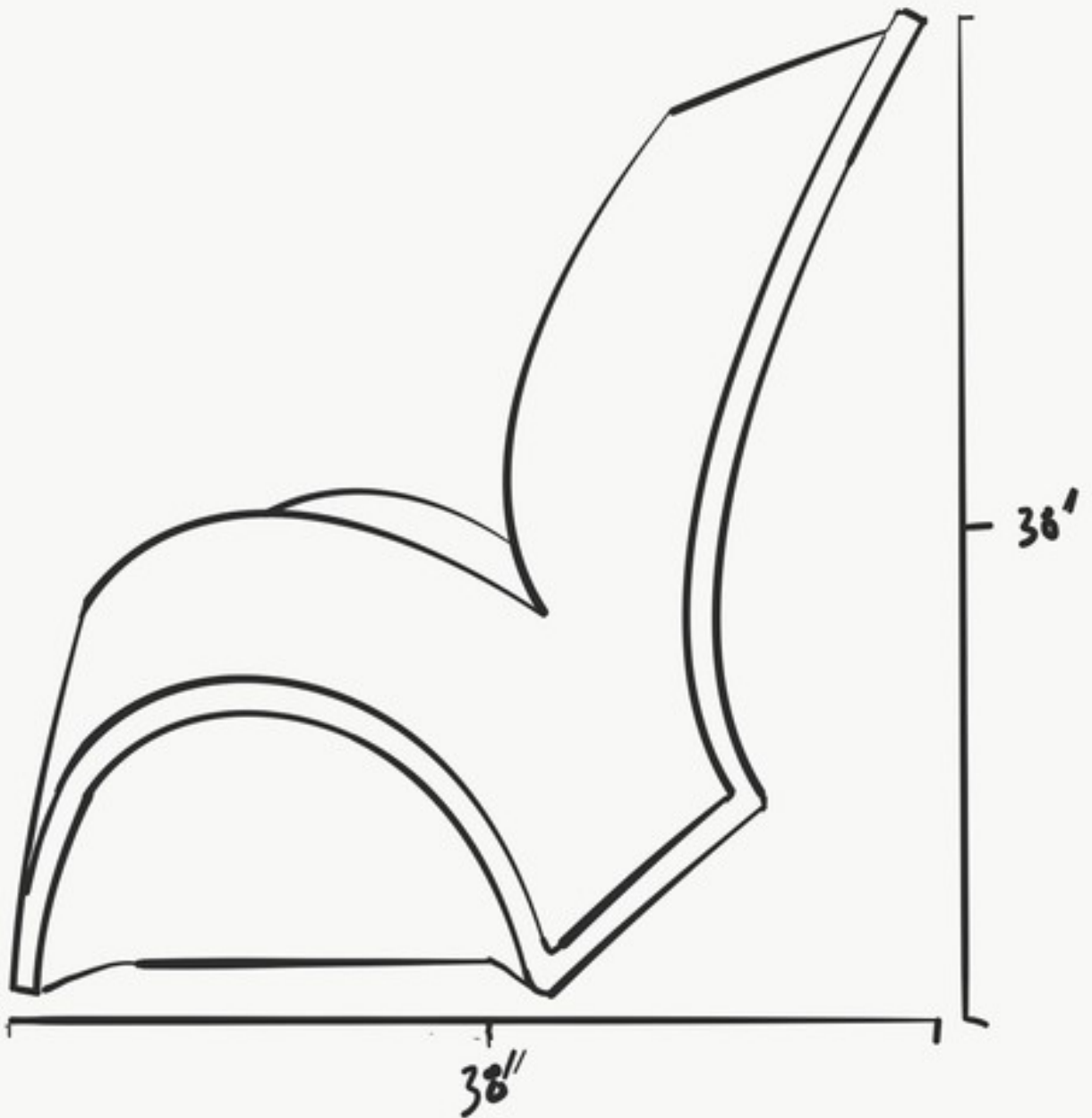

Mentor Storybook Bench Project

Transform a Fiberglass Book Bench into Vibrant Art!

Artist Application Form

Entry Deadline: March 17, 2025 | 4:00pm

Entry Fee of \$40 - checks payable to the City of Mentor

Artist Name: _____

Phone Number: _____

Email Address: _____

Street Address: _____

City: _____ State: _____ Zip Code: _____

Business Website if applicable: _____

Business Facebook/Instagram Page: _____

Below write the title of the design and a brief description of the art piece. This will be used during the review of the submission, and if chosen will be used in public relations/media announcements regarding the project:

How I plan to take my design from concept to completed work; materials used, process etc. (attach a separate page, if necessary)

Entry Deadline: Application forms, design diagrams, resume and/or samples of your artwork must be received by 4:00pm on March 17, 2025. Send your submissions via email to wildwood@cityofmentor.com or by mail to: Wildwood Cultural Center, Att. Storybook Benches, 8500 Civic Center Blvd., Mentor, Ohio 44060. Make checks payable to City of Mentor.

I _____ (applicant's printed name) understand that if my submission is selected and I design a book bench, all rights, title and interest to the submitted design will become the sole property of City of Mentor and I relinquish all rights, title and interest in the design and the finished book bench sculpture.

Applicant's Signature: _____ Date: _____

For questions or additional information, contact
Wildwood Cultural Center at 440-974-5735 or wildwood@cityofmentor.com.

Mentor Storybook Bench Project

Transform a Fiberglass Book Bench into Vibrant Art!

Artist Application Form

Entry Deadline: March 17, 2025 | 4:00pm

Entry Fee of \$40 - checks payable to the City of Mentor

COPYRIGHT ASSIGNMENT

WHEREAS, _____ [Artist Name], an individual having an address of _____ [Artist Address] is the author of the design and sketches (collectively referred to as the “Design”) attached to the application submitted to Mentor Community Arts Commission on the same date as the date of this Assignment;

WHEREAS, Artist understands and acknowledges that, as part of the application process, it is intended that the City of Mentor, with an address of 8500 Civic Center Blvd. Mentor, OH 44060 own the entire right, title and interest in and to the Design;

WHEREAS, Artist understands and acknowledges that, if the Design is approved, he/she shall apply that design to a bench sculpture provided by Mentor Community Arts Commission thereby creating a “Book Bench Sculpture.”

WHEREAS, Artist desires to transfer all of his/her right, title and interest in and to the Design, including, but not limited to, all derivative works which are based on the Design to the City of Mentor.

WHEREAS, Artist understands and acknowledges that City of Mentor shall continue to be the sole and exclusive owner of the entire right, title and interest in and to the Design, including, but not limited to, all derivative works based on the Design if the Book Bench Sculpture is approved for exhibition, as described in detail in the Request For Proposals and Application Mentor’s Story Book Bench Project and that in such case Mentor Community Arts Commission shall pay to Artist an honorarium of \$500.00 total, paying \$100 of that upon design acceptance by a sponsor, for production costs, with the final \$400 paid upon completion of their bench.

NOW, THEREFORE, for good and valuable consideration, receipt of which is hereby acknowledged, and intending to be legally bound hereby, Artist hereby assigns to City of Mentor all his/her right, title and interest in and to the Design, and to any derivative works based on the Design including but not limited to any rights it may have in the Book Bench Sculpture, together with any and all copyright applications and registrations, therefore. Artist acknowledges and agrees that, due to the nature of the public display of the Book Bench Sculpture, City of Mentor shall not be liable for any distortion, mutilation, modification, or destruction of the Finished Bench by accident, act of God or person. Artist hereby waives his/her rights under the Visual Artists Rights Act (“VARA”), 17 U.S.C. '106A, as against City of Mentor in the event of such distortion, mutilation, modification, or destruction. Artist further acknowledges and agrees that if the Book Bench Sculpture is vandalized, damaged, or otherwise modified and the Artist is unable or unwilling to promptly repair such alteration, City of Mentor shall have the right to make, or have made, such repairs, even if the repairs would constitute a distortion, mutilation, or modification under VARA. Artist hereby waives his/her rights under VARA in the event and to the extent City of Mentor deems such repair necessary. Artist represents to The Story Book Bench Project that he/she is the sole author of the Designs and that the Design is an original work of authorship which does not infringe upon the copyright rights or any intellectual property rights of others, and that he/she has the unencumbered right to make this assignment. In the event the Design is not approved or selected for exhibition, as described in the Request for Proposals, Mentor Community Arts Commission shall assign [and hereby does assign] back to Artist all its right, titles and interest in and to the Design.

Artist Signature: _____

Print Name: _____

Book Bench Title: _____

Date: _____



the GREAT American READ

Storybook Bench Project Design Elements

- **Storybook Characters:** Choose a book from the PBS, Great American Read 100 book list.
- **Literary Quotes:** Quotes could be included along the edges of the bench.
- **Vibrant Colors:** Adorn the book benches with a palette of bright and inviting colors to attract attention and evoke curiosity.
- **Sealing and Finishing:** A protective sealant will be provided to the artist that once applied will maintain the integrity of the artwork, protecting it from the elements and ensuring longevity.

- 1984** George Orwell
#VOTE1984 1-855-443-6500
- A Confederacy of Dunces** John Kennedy Toole
#VOTEDuncesBook 1-855-443-6501
- A Prayer for Owen Meany** John Irving
#VOTEOwenMeany 1-855-443-6502
- A Separate Peace** John Knowles
#VOTEPeaceBook 1-855-443-6503
- A Tree Grows in Brooklyn** Betty Smith
#VOTEBrooklyn 1-855-443-6504
- The Adventures of Tom Sawyer** Mark Twain
#VOTESawyer 1-855-443-6505
- The Alchemist** Paulo Coelho
#VOTEAlchemist 1-855-443-6506
- Alex Cross Mysteries** (series) James Patterson
#VOTEAlexCross 1-855-443-6507
- Alice's Adventures in Wonderland** Lewis Carroll
#VOTEAlice 1-855-443-6508
- Americanah** Chimamanda Ngozi Adichie
#VOTEAmericanah 1-855-443-6509
- And Then There Were None** Agatha Christie
#VOTEAndThen 1-855-443-6510
- Anne of Green Gables** Lucy Maud Montgomery
#VOTEGables 1-855-443-6511
- Another Country** James Baldwin
#VOTECountryBook 1-855-443-6512
- Atlas Shrugged** Ayn Rand
#VOTEAtlas 1-855-443-6513
- Beloved** Toni Morrison
#VOTEBeloved 1-855-443-6514
- Bless Me, Ultima** Rudolfo Anaya
#VOTEUltima 1-855-443-6515
- The Book Thief** Markus Zusak
#VOTEBookThief 1-855-443-6516
- The Brief Wondrous Life of Oscar Wao** Junot Díaz
#VOTEOscarWao 1-855-443-6517
- The Call of the Wild** Jack London
#VOTECallWild 1-855-443-6518
- Catch-22** Joseph Heller
#VOTECatch22 1-855-443-6519
- The Catcher in the Rye** J.D. Salinger
#VOTECatcherRye 1-855-443-6520
- Charlotte's Web** E.B. White
#VOTECharlotte 1-855-443-6521
- The Chronicles of Narnia** (series) C.S. Lewis
#VOTENarnia 1-855-443-6522
- The Clan of the Cave Bear** Jean M. Auel
#VOTECaveBear 1-855-443-6523
- The Coldest Winter Ever** Sister Souljah
#VOTEWinterBook 1-855-443-6524
- The Color Purple** Alice Walker
#VTEColorPurple 1-855-443-6525
- The Count of Monte Cristo** Alexandre Dumas
#VOTEMonteCristo 1-855-443-6526
- Crime and Punishment** Fyodor Dostoyevsky
#VOTECrimeBook 1-855-443-6527
- The Curious Incident of the Dog in the Night-Time** Mark Haddon
#VOTECurious 1-855-443-6528
- The Da Vinci Code** Dan Brown
#VOTEDaVinci 1-855-443-6529
- Don Quixote** Miguel de Cervantes
#VOTEQuixote 1-855-443-6530
- Doña Bárbara** Rómulo Gallegos
#VOTEBarbara 1-855-443-6531
- Dune** Frank Herbert
#VOTEDune 1-855-443-6532
- Fifty Shades of Grey** (series) E.L. James
#VOTE50Shades 1-855-443-6533
- Flowers in the Attic** V.C. Andrews
#VOTEFlowers 1-855-443-6534
- Foundation** (series) Isaac Asimov
#VOTEFoundation 1-855-443-6535
- Frankenstein** Mary Shelley
#VOTEFrankenstein 1-855-443-6536
- A Game of Thrones** (series) George R.R. Martin
#VOTEGOT 1-855-443-6537
- Ghost** Jason Reynolds
#VOTEGhost 1-855-443-6538
- Gilead** Marilynne Robinson
#VOTEGilead 1-855-443-6539
- The Giver** Lois Lowry
#VOTEGiver 1-855-443-6540
- The Godfather** Mario Puzo
#VOTEGodfather 1-855-443-6541
- Gone Girl** Gillian Flynn
#VOTEGoneGirl 1-855-443-6542
- Gone with the Wind** Margaret Mitchell
#VOTEGoneWind 1-855-443-6543

The list continues on the back >

- ❑ **The Grapes of Wrath** John Steinbeck
#VOTEGrapesWrath 1-855-443-6544
- ❑ **Great Expectations** Charles Dickens
#VOTEGreatExpect 1-855-443-6545
- ❑ **The Great Gatsby** F. Scott Fitzgerald
#VOTEGatsby 1-855-443-6546
- ❑ **Gulliver's Travels** Jonathan Swift
#VOTEGulliver 1-855-443-6547
- ❑ **The Handmaid's Tale** Margaret Atwood
#VOTEHandmaid 1-855-443-6548
- ❑ **Harry Potter** (series) J.K. Rowling
#VOTEPotter 1-855-443-6549
- ❑ **Hatchet** (series) Gary Paulsen
#VOTEHatchet 1-855-443-6550
- ❑ **Heart of Darkness** Joseph Conrad
#VOTEHeartDark 1-855-443-6551
- ❑ **The Help** Kathryn Stockett
#VOTTheHelp 1-855-443-6552
- ❑ **The Hitchhiker's Guide to the Galaxy** Douglas Adams
#VOTEGalaxy 1-855-443-6553
- ❑ **The Hunger Games** (series) Suzanne Collins
#VOTEHungerGames 1-855-443-6554
- ❑ **The Hunt for Red October** Tom Clancy
#VOTERedOctober 1-855-443-6555
- ❑ **The Intuitionist** Colson Whitehead
#VOTEIntuition 1-855-443-6556
- ❑ **Invisible Man** Ralph Ellison
#VOTEInvisible 1-855-443-6557
- ❑ **Jane Eyre** Charlotte Brontë
#VOTEJaneEyre 1-855-443-6558
- ❑ **The Joy Luck Club** Amy Tan
#VOTEJoyLuck 1-855-443-6559
- ❑ **Jurassic Park** Michael Crichton
#VOTEJurassic 1-855-443-6560
- ❑ **Left Behind** (series) Tim LaHaye and Jerry B. Jenkins
#VOTELeftBehind 1-855-443-6561
- ❑ **The Little Prince** Antoine de Saint-Exupéry
#VOTEPrinceBook 1-855-443-6562
- ❑ **Little Women** Louisa May Alcott
#VOTELittleWomen 1-855-443-6563
- ❑ **Lonesome Dove** Larry McMurtry
#VOTELonesome 1-855-443-6564
- ❑ **Looking for Alaska** John Green
#VOTEAlaska 1-855-443-6565
- ❑ **The Lord of the Rings** (series) J.R.R. Tolkien
#VOTELOTR 1-855-443-6566
- ❑ **The Lovely Bones** Alice Sebold
#VOTELovelyBones 1-855-443-6567
- ❑ **The Martian** Andy Weir
#VOTEMartian 1-855-443-6568
- ❑ **Memoirs of a Geisha** Arthur Golden
#VOTEGeisha 1-855-443-6569
- ❑ **Mind Invaders** Dave Hunt
#VOTEInvaders 1-855-443-6570
- ❑ **Moby-Dick** Herman Melville
#VOTEMobyDick 1-855-443-6571
- ❑ **The Notebook** Nicholas Sparks
#VOTENotebook 1-855-443-6572
- ❑ **One Hundred Years of Solitude** Gabriel García Márquez
#VOTE100Years 1-855-443-6573
- ❑ **Outlander** (series) Diana Gabaldon
#VOTEOutlander 1-855-443-6574
- ❑ **The Outsiders** S.E. Hinton
#VOTEOutsiders 1-855-443-6575
- ❑ **The Picture of Dorian Gray** Oscar Wilde
#VOTEDorian 1-855-443-6576
- ❑ **The Pilgrim's Progress** John Bunyan
#VOTEPilgrims 1-855-443-6577
- ❑ **The Pillars of the Earth** Ken Follett
#VOTEPillars 1-855-443-6578
- ❑ **Pride and Prejudice** Jane Austen
#VOTEPrizePrej 1-855-443-6579
- ❑ **Ready Player One** Ernest Cline
#VOTEPlayer1 1-855-443-6580
- ❑ **Rebecca** Daphne du Maurier
#VOTERebecca 1-855-443-6581
- ❑ **The Shack** William P. Young
#VOTTheShack 1-855-443-6582
- ❑ **Siddhartha** Hermann Hesse
#VOTESidd 1-855-443-6583
- ❑ **The Sirens of Titan** Kurt Vonnegut
#VOTESirens 1-855-443-6584
- ❑ **The Stand** Stephen King
#VOTTheStand 1-855-443-6585
- ❑ **The Sun Also Rises** Ernest Hemingway
#VOTESunRises 1-855-443-6586
- ❑ **Swan Song** Robert R. McCammon
#VOTESwanSong 1-855-443-6587
- ❑ **Tales of the City** (series) Armistead Maupin
#VOTETalesCity 1-855-443-6588
- ❑ **Their Eyes Were Watching God** Zora Neale Hurston
#VOTEWatchingGod 1-855-443-6589
- ❑ **Things Fall Apart** Chinua Achebe
#VOTEFallApart 1-855-443-6590
- ❑ **This Present Darkness** Frank E. Peretti
#VOTEDarkness 1-855-443-6591
- ❑ **To Kill a Mockingbird** Harper Lee
#VOTEMockingbird 1-855-443-6592
- ❑ **The Twilight Saga** (series) Stephenie Meyer
#VOTETwilight 1-855-443-6593
- ❑ **War and Peace** Leo Tolstoy
#VOTWarPeace 1-855-443-6594
- ❑ **Watchers** Dean Koontz
#VOTEWatchers 1-855-443-6595
- ❑ **The Wheel of Time** (series) Robert Jordan and Brandon Sanderson
#VOTWheelTime 1-855-443-6596
- ❑ **Where the Red Fern Grows** Wilson Rawls
#VOTERedFern 1-855-443-6597
- ❑ **White Teeth** Zadie Smith
#VOTEWhiteTeeth 1-855-443-6598
- ❑ **Wuthering Heights** Emily Brontë
#VOTEWuthering 1-855-443-6599

READ. VOTE. SHARE.

pbs.org/greatamericanread | #GreatReadPBS

Detailed information about voting rules and conditions are available on the website.



PBS