

City of Mentor

**BID SET**

**Decorative Street Lights  
Materials Only**

---

**Prepared under the supervision  
of Dave Rorapaugh  
Date August 30, 2019**

**Approved By: Matt Schweikert  
Director of Public Works Date  
August 30, 2019**

## **CITY OF MENTOR OFFICIALS**

### **ADMINISTRATION**

Kenneth J. Filipiak, City Manager

David W. Malinowski, Finance Director

Joseph P. Szeman, Law Director

David A. Swiger, City Engineer

Matthew Schweikert, Director of Public Works

Kenneth Kaminski, Director of Parks, Recreation and Public Facilities

Kevin Malecek, Economic Development Director

Kathleen Mitchell, Planning Director

Kevin Knight, Chief of Police

Robert Searles, Fire Chief

### **COUNCIL**

John A. Krueger, President, Ward 4 Councilman

Bruce R. Landeg, Vice President, Ward 3 Councilman

Sean P. Blake, Ward 1 Councilman

Matthew E. Donovan, Ward 2 Councilman

Janet A. Dowling, Councilwoman-at-Large

Ray Kirchner, Councilman-at-Large

Scott J. Marn, Councilman-at-Large

Julie Schiavoni, Clerk of Council

THE CITY OF MENTOR  
8500 CIVIC CENTER BOULEVARD  
MENTOR, OH 44060

SPECIFICATIONS AND BID FORMS FOR:

**Decorative Street Lighting – Material only**

**CONTENTS:**

I. LEGAL NOTICE ..... Page LN-1

II. INSTRUCTIONS TO BIDDERS ..... Pages IB-4B

III. BUSINESS ENTITY RESOLUTION..... Page BER-1

IV. NONCOLLUSION AFFIDAVIT ..... Page NCA-1

V. BID SUBJECT TO ACCEPTANCE AS CONTRACT.. BAC 1 - 6

VI. SPECIFICATIONS..... Pages 7 - 9

VII. PROPOSAL-CONTRACT FORM ..... Pages 10

VIII. STATEMENT OF BIDDER QUALIFICATIONS .....Pages 11 – 12

VIII. NORTH YORKSHIRE (OR EQUAL) SERIES POLE DRAWINGS

CITY OF MENTOR  
PURCHASING OFFICE

**DATE: September 13, 2019**

**12:00 noon**

ALL BIDS SUBMITTED MUST INCLUDE THE REQUIRED BID DEPOSIT AND A PROPERLY EXECUTED ***BID SUBJECT TO ACCEPTANCE AS CONTRACT.***

**BID SUBJECT TO ACCEPTANCE AS CONTRACT (BAC-1)** has been intentionally omitted. Please contact VERONICA FETSKO, at 440-974-5776 or fetsko@cityofmentor.com to request a copy of the omitted form.

**I. LEGAL NOTICE**

The CITY OF MENTOR will receive sealed bids at the Purchasing Department, 8500 Civic Center Blvd., Mentor, Ohio 44060, until NOON (local time) on September 13, 2019 and will be opened and read immediately thereafter for the following project:

**Decorative Street Lights - Materials Only**

Bids must be in accordance with specifications advertised on the City of Mentor website: [www.cityofmentor.com/category/rfp](http://www.cityofmentor.com/category/rfp) or RFP's will be available for the cost of printing, pick-up at the Purchasing Office. The bidder shall be responsible to check for Addenda and obtain same from the website.

Kenneth Filipiak, City Manager  
(cityofmentor.com)

NEWS HERALD:

PUBLISH DATES:

August 30, 2019  
September 6, 2019

## II.

### INSTRUCTIONS TO BIDDERS

*The Instructions to Bidders governs, except where amended by the Specifications.*

The Bidder is responsible for reading and understanding all items herein:

1. Except as otherwise provided herein, the Instructions to Bidders, Proposal-Contract Form, and all specifications, drawings and other documents referred to herein shall be a part of the contract.

2. DEFINITIONS:

A. The term "Bidder" or "Contractor" shall mean the corporation, partnership or individual proposing or under contract to furnish the material, labor, and/or equipment listed in the Specifications.

B. The term "City" shall mean the City of Mentor, Ohio.

C. "Calendar Day" shall mean every day shown on the calendar.

D. "City Manager" shall mean the Mentor City Manager or his duly authorized representative.

3. PROPOSAL: To be entitled to consideration, a proposal must be made in accordance with the following instructions:

A. Preparation: Each proposal shall be submitted on the forms furnished by the City. All signatures shall be clearly and legibly written in long hand. No oral, facsimile or telephonic proposal or modifications will be considered. Each proposal shall show the breakdown for each item as directed on the Proposal-Contract Form. All proposals shall be considered informal which contain items not specified in the Proposal-Contract Form.

Prices for material and equipment shall include transporting and delivery to any place designated on the City's purchase order, within the corporate limits of the City. In the event of a discrepancy between unit proposal prices and extension thereof, the unit proposal price shall govern.

B. Names of Bidders: Each proposal shall give the full business address of the Bidder(s) and be signed by them with their usual signature. Proposals by partnerships shall furnish the full names of all partners and shall be signed with the partnership name by one of the members of the partnership or by an authorized representative, followed by the signature and title of the person signing.

Proposals by corporations must be signed with the legal name of the corporation, followed by the name of the state of incorporation and by the signature and title of the President, Secretary or other person authorized to bind it in the matter.

The name of each person signing shall also be typed or printed below the signature. A proposal by a person

who affixes to their signature the word "President," "Secretary," "Agent" or other title without disclosing their principal may be held to be the proposal of the individual signing.

When requested by the City, satisfactory evidence of the authority of the officer or agent signing on behalf of a corporation or partnership shall be furnished.

C. Delivery: The proposal shall be sealed in an envelope, addressed to:

City of Mentor  
c/o Purchasing Department  
8500 Civic Center Boulevard  
Mentor, Ohio 44060

and delivered to the office of the Purchasing Coordinator on the date set forth in the legal advertisement. The sealed envelope shall also bear the name of the Bidder, the general item(s) proposed, and the date the proposals are to be opened. Proposals will be received until the date and time specified in the legal advertisement. Proposals will be opened and read immediately thereafter, in 2nd Floor Conference Room, Mentor Municipal Center. Proposals received after the date and time specified will be returned unopened to the Bidder.

D. Proposal to Include All Work: Each proposal shall include all equipment, material, supplies or services described in the Instructions to Bidders, Specifications, Proposal-Contract Form and all drawings.

E. Withdrawal of Proposal: Permission will not be given to withdraw or modify any proposal after it has been deposited as provided above. Negligence on the part of a Bidder in preparing the proposal confers no right for the withdrawal of the proposal after it has been opened.

F. Acceptance or Rejection of Proposal: The City reserves the right to accept any proposals within sixty (60) calendar days after the same are opened, as provided above. The City reserves the right to accept any proposals which, in its opinion, are deemed to be in the best interest of the City. The City reserves the right to reject any or all proposals.

In determining the award, each item may be considered separately, and separate contracts may be awarded on the various items, unless specified to the contrary in the Specifications.

G. Proposal Bond or Check: Each proposal must be accompanied by a cashier's or certified check, an irrevocable letter of credit, or by a proposal bond, signed by a surety company authorized to do business in the State

of Ohio, in the amount of five (5) percent of the proposal and made payable to the City of Mentor, as a guarantee that the contract will be honored in the event it is awarded to the Bidder, and as a guarantee that the Bidder to whom the contract is awarded will sign all documents necessary to formalize the contract, if any.

H. Forfeiture of Check or Proposal Bond: If the Bidder to whom the contract is awarded shall fail to honor the contract, or fail to sign the documents necessary to formalize the contract, if any, the deposit accompanying the proposal shall thereupon be forfeited to the City for and as liquidated damages. The work may then be readvertised or awarded to the deemed second best Bidder as the City may determine.

I. Quantities: The quantities of the work shown on the Specifications and Proposal-Contract Form are estimated by the City and will be used as the basis for comparison of the proposals only. The City reserves the right to decrease or increase any quantities and to eliminate any item(s) on the plans or proposal.

J. Informal Proposals: Proposals may be rejected for the following reasons:

- 1) If the proposal is on a form other than that furnished by the City or if the form is altered or any part thereof detached.
- 2) If there are any unauthorized additions, conditional or alternate proposals, or other irregularities of any kind which may tend to make the proposal incomplete, indefinite or ambiguous as to its meaning.
- 3) If the Bidder adds any provisions reserving the right to accept or reject an award, or to enter into a contract pursuant to an award. This does not exclude a proposal limiting the maximum gross amount of awards acceptable to any one Bidder at any one proposal letting, provided that the City will make any selection of awards.
- 4) If the proposal does not contain a unit price for each pay item listed, except in the case of authorized alternate pay items or lump sum items.

4. A. Competency of Bidders: No proposal will be considered unless the Bidder submitting the same shall furnish evidence satisfactory to the City Manager that they have the necessary equipment, ability and financial resources to fulfill the conditions of the contract and Specifications. Previous experience and responsibility of the Bidders will be considered in awarding the contract. No contract will be awarded to any Bidder who is in arrears to the City upon debt or contract, or who is in default as surety or otherwise upon any obligation to the City.

B. Disqualification of Bidders: Any of the following reasons may be considered as being sufficient for the disqualification of a Bidder and the rejection of their proposal or proposals.

- 1) More than one proposal for the same work from an individual, firm or corporation under the same or different names.
- 2) Evidence of collusion among Bidders. Participants in such collusion will receive no recognition as Bidders for any further work of the City until any such participant shall have been reinstated as a qualified Bidder.
- 3) Proposal prices that obviously are unbalanced.

5. WRITTEN AND ORAL EXPLANATIONS: Should a Bidder find discrepancies in, or omissions from, the drawings or Specifications, or should they be in doubt as to their meaning, they shall at once notify the City, which may send written instructions to all Bidders. The City will not be responsible for any oral instructions.

6. ADDENDUM OR MODIFICATION: Any addendum or modification issued during the time of bidding shall be covered in the proposal and in awarding a contract, such addendum or modification will become part thereof. In the event any such addendum or modification is issued by the City within 72 hours of the time set for the closing of proposals, excluding Saturdays, Sundays and legal holidays, the time for submitting proposals shall be extended one (1) week, with no further advertising of proposals.

7. TAX EXEMPTIONS: The City is exempt from federal excise and transportation taxes and Ohio State sales tax. Prices quoted should not include either federal excise or Ohio State sales tax. Tax exemption certificates covering these taxes will be furnished upon request.

The transportation tax is not applicable on any purchase consigned to the City and no tax exemption certificate is required. If for any reason a contemplated purchase would not be tax exempt, this fact will be indicated in the Specifications, and such taxes may be included in the price or shown as a separate item in the proposal.

8. DISCRIMINATION: In hiring of employees for the performance of work under this contract or any subcontract, neither the Contractor, subcontractor, nor any person acting in their behalf shall by reason of race, creed, color, age, sex or handicap discriminate against any citizen of the State in the employment of any laborer or worker who is qualified and available to perform the work to which the employment relates.

Neither the Contractor, subcontractor, nor any person in their behalf shall in any manner discriminate against or intimidate any employee hired for the performance of work under this contract on account of race, creed, color, age, sex or handicap.

9. INSURANCE: If the Specifications indicate insurance is required, then the Contractor shall obtain and pay for liability insurance, \$1,000,000 combined single limit for each occurrence--to protect the Contractor and the City against any claims arising out of any operations conducted in connection with the contract. **The policy shall carry a rider giving a**

**one-month (30-day) cancellation notice to the City. This policy shall include contractual liability insurance as applicable to the Contractor's obligations and shall name the City of Mentor as additionally insured.**

10. **LIABILITY:** The Bidder shall defend, indemnify, and save harmless the City and its officers and agents from all claims, demands, payments, suits, actions, recoveries and judgments of every description, whether or not well founded by law, brought or recovered against it, by reason of any act or omission of said Bidder(s), their agents, subcontractors or employees, in the execution of the contract, or for the use of any patented inventions by said Bidder. A sum sufficient to cover aforesaid claims, including attorneys' fees, may be retained by the City from monies due or to become due to the Bidder under contract, until such claims shall have been discharged.
11. **ROYALTIES AND/OR LICENSE FEES:** The Bidder shall pay all royalties and license fees. The Bidder herein agrees to assume and save the City, its officers and agents harmless from liability of any kind or nature whatsoever, arising out of the use by the City, its officers and agents of any item, appliance, apparatus or mechanism, material or service which may be furnished or installed by the Bidder under the terms of this contract, including patent or copyright infringement, and to defend the City from any and all such liabilities whether or not such claims are well founded by law.
12. **ASSIGNMENT OF CONTRACT:** The Bidder who is awarded a contract shall not assign, transfer, convey, sublet or otherwise dispose of said contract, or right, title or interest in or to the same, or any part thereof, without previous consent in writing from the City Manager, endorsed on or attached to the contract.
13. **CANCELLATION:** Should the material(s) supplied or delivered to the City under this contract fail at any time to meet the Specifications required by the contract, then in such event, the City may cancel this contract upon written notice to the Bidder.
14. **CONTROL OF WORK:** The City Manager, or his designated agent, will decide all questions which may arise as to the quality and acceptability of materials furnished and work performed and as to the rate of progress of the work; all questions which may arise as to the interpretation of the plans and Specifications; all questions as to the acceptable fulfillment of the contract on the part of the Contractor, and as to compensation.
15. **CLAIMS FOR ADJUSTMENT AND DISPUTES:** If, in any case, the Contractor deems that additional compensation is due for work or material not clearly covered in the contract or not ordered by the City Manager as extra work, as defined herein, the Contractor shall notify the City Manager in writing of their intention to make claim for such additional compensation before they begin the work on which the claim is based. If such notification is not given and the City Manager is not afforded proper facilities by the Contractor for keeping strict account of actual costs as required, then the Contractor hereby agrees to waive any claim for such additional compensation. Such notice by the Contractor, and the fact that the City Manager has kept account

of the cost aforesaid, shall not in any way be construed as proving or substantiating the validity of the claim. If the claim, after consideration by the City Manager, is found to be just, it will be paid as extra work in the amount as approved by the City Manager.

16. **DURATION OF CONTRACT:** The duration of the contract shall be for the period stated in the Specifications, and shall include all material, equipment and/or services ordered or delivered during the period. All prices quoted shall be for a definite fixed period unless otherwise noted in the Specifications.
17. **PURCHASES:** After a contract has been signed, it shall only become operative upon delivery to the Bidder a duly signed purchase order. The City shall only be obligated under the contract to the extent of such purchase order. The City shall not become liable for any claims in the event that the total quantity of material ordered or services performed under the contract should prove to be greater or less than the estimated amount in the Specifications.
18. **DELIVERY:** The Bidder agrees to make deliveries of supplies and materials within a reasonable period from the time purchase orders are received, which reasonable time is estimated to be thirty (30) days.

If deliveries are not made within such period, then the City may purchase such items in the open market; and if the prices paid by the City shall be greater than the contract price, the Bidder agrees to reimburse the City for any loss or losses that the City may thereby sustain.

Delivery time for vehicles and equipment may be extended beyond thirty (30) days, provided the Bidder has noted the delivery time in the appropriate space on the Proposal-Contract Form.

19. **PAYMENT OF INVOICES:** Invoices will be due and payable within thirty (30) days of receipt of the invoice by the City. All invoices should be mailed to the attention of the Accounts Payable Department. Payments may be made on a basis of estimated partial completion of work or delivery, and the City may withhold a percentage of each partial payment until completion of the contract. The City may withhold a percentage of the final estimate for a specified period as a guarantee. Such a procedure for partial payments must be provided for in the Specifications.
20. **CONTRACT BOND:** The successful Bidder will be required to furnish the approved bond for the faithful performance of the contract in the amount of one hundred percent (100%) of the contract price. Such bond shall be that of an approved surety company or personal bond upon which the sureties are persons not interested in the contract, or, if interested, collateral security shall be furnished, all of which is to be to the satisfaction of the Law Director, including sureties.

In lieu of a performance bond the City may elect to hold the Proposal Deposit Check, submitted with the proposal, until the contract has been fulfilled. **Any deviation from the required one hundred percent (100%) figure will be noted in the Specifications.**

21. GENERAL: Contractors shall furnish all labor, equipment, materials, services and supplies necessary to complete the proposed work. All work shall be performed according to all standards of good workmanship complete in every detail. Contractors shall coordinate their work with the work of others and, upon completion, remove tools, equipment, waste and debris and leave the site in "broom-clean" condition. Contractors shall warrant all equipment, materials, services and supplies with the normal and usual warranties, including, where applicable, warranties of merchantability and fitness for a particular purpose.
22. WAIVERABILITY: The City of Mentor reserves the right to accept any part of any proposal and reject all or parts of any and all proposals, and waive any informalities in the bidding procedure.
23. PREVAILING WAGE: Contractors must comply with ORC Chapter 4115 when applicable. It is the Contractor's responsibility to contact the City's Prevailing Wage Coordinator to determine requirements.
24. TAXES: Contractor shall pay and/or withhold all sales, consumer, use, employment and other taxes (including the City of Mentor 2% income tax) paid or withheld by Contractor in accordance with the Laws and Regulations of the United States, State of Ohio and City of Mentor which are applicable during the performance of the work.

QUESTIONS: Call the Finance Department at (440) 974-5776.



### III. BUSINESS ENTITY RESOLUTION

\_\_\_\_\_, of \_\_\_\_\_  
(Name of Officer) (Name of Business Entity)

an \_\_\_\_\_ Business Entity hereby certifies that the following is a true  
(State where incorporated/organized if applicable)

and correct copy of a resolution duly adopted by the Board of Directors of \_\_\_\_\_,  
(Business Entity Name)

on \_\_\_\_\_, \_\_\_\_\_, to wit:  
(Month, Day) (Year)

“Resolved, that \_\_\_\_\_\* of this Business Entity, namely  
(Name of Officer)

\_\_\_\_\_, be and he/she hereby is authorized and directed to enter into any and all  
(Title of Officer)

contracts, bid guaranty and performance bonds with **THE CITY OF MENTOR, OHIO**, for the purpose of

furnishing labor and/or materials as to \_\_\_\_\_  
(Title of Bid)

at such price and upon such terms and conditions, including any amendments or modifications thereto, as

said \_\_\_\_\_ in his/her sole discretion shall deem best,  
(Title of Officer)

and that said actions shall be binding upon the Business Entity.

“Resolved, further, that said \_\_\_\_\_\* be, and he/she further is  
(Name of Officer)

hereby authorized and directed to execute and deliver unto said **CITY OF MENTOR, OHIO** other  
instruments which in his/her discretion he/she shall deem necessary to carry out the forgoing resolution.”

IN WITNESS WHEREOF, I have hereunto set my hand and affixed the seal of said Business  
Entity (if applicable) at \_\_\_\_\_ this \_\_\_\_\_ day of \_\_\_\_\_,  
and I further certify that said resolution is still in force and effect.

\_\_\_\_\_  
**SECRETARY**

**SEAL**

BER-1

\*Name must agree with signature on *Bid Subject to Acceptance as Contract* Form (BAC-1).

**IV. FORM OF NONCOLLUSION AFFIDAVIT**

STATE OF \_\_\_\_\_ )  
 ) SS  
COUNTY OF \_\_\_\_\_ )

\_\_\_\_\_, being first duly sworn, deposes  
(Individual Name)

and says that he/she is \_\_\_\_\_ of \_\_\_\_\_  
(Sole Owner, Partner, President, Secretary, etc.) (Corporation Name)

the party making the proposal or bid; that such bid is genuine and not collusive or sham; that said Bidder has not colluded, conspired, connived, or agreed, directly or indirectly with any Bidder or person, to put in a sham bid, or that such other person shall refrain from bidding, and has not in any manner, directly or indirectly sought by agreement or collusion or communication or conference, with any person, to fix the bid price of affiant or any other Bidder, or to fix any overhead, profit, or cost element of said Bid price, or of that of any other Bidder, or to secure any advantage against the Owner, or any person interested in the proposed Contract; and that all statements contained in said proposal or bid are true; and further, that such Bidder has not, directly or indirectly submitted this Bid, or the contents thereof, or divulged information or data relative thereto to any association or to any member or agent thereof.

\_\_\_\_\_  
Affiant

Subscribed and sworn to before me this \_\_\_\_\_ day of \_\_\_\_\_, 2019.

\_\_\_\_\_  
Notary Public

My Commission Expires:\_\_\_\_\_

## V. BID SUBJECT TO ACCEPTANCE AS CONTRACT

Page intentionally left blank, contact Veronica Fetsko at [fetsko@cityofmentor.com](mailto:fetsko@cityofmentor.com) or 440-974-5776 for the omitted form.

## B. NOTICE OF AWARD

Whereas, \_\_\_\_\_ responded to an invitation to bid as to Sandblasting and Painting Services for Civic Center Waterpark and Wading Pools and whereas said bid by \_\_\_\_\_ was approved by the City Council as the lowest and best bid, now, therefore, the City of Mentor awards the contract subject to final acceptance below to \_\_\_\_\_ to be performed pursuant to the terms and conditions specified in the following documents (component parts):

1. Instructions to Bidders
2. Bond or Certified Check
3. Specifications: General Requirements/Contractor's Responsibilities
4. Proposal/Contract Form
5. Other

\_\_\_\_\_  
Veronica Fetsko, **Purchasing**

\_\_\_\_\_  
**Date**

## C. VENDOR AGREEMENT

\_\_\_\_\_ hereby agrees to perform the services as bid and agrees to abide by all terms and conditions as identified. In the event of contradiction or ambiguity between the paragraphs contained in the *Instructions to Bidders* versus the other more specific paragraphs under *Specifications: General Requirements/Contractor's Responsibilities, Proposal/Contract Form, Other*, the paragraphs in the *Specifications: General Requirements/Contractor's Responsibilities, Proposal/Contract Form and Other*, shall control. And whereas, the City of Mentor intends to be bound by the contract, it will pay to \_\_\_\_\_ the sums so stated in the *Proposal/Contract Form* upon satisfactory delivery of the goods and/or performance of the service.

\_\_\_\_\_ has reviewed the above component parts of the contract documents and finds no ambiguity in the terms and conditions thereof.

\_\_\_\_\_  
, **Company Officer**

\_\_\_\_\_  
**Date**

**D. ACCEPTANCE BY THE CITY OF MENTOR**

THE FOREGOING CONTRACT IS HEREBY ACCEPTED AS TO ALL OF THE COMPONENT PARTS AND, IN SPECIFIC, TO ITEM(S) #

Item(s) #

Pursuant to Ordinance \_\_\_\_\_ Passed on \_\_\_\_\_.

By the Council of the City of Mentor, from receipt of Purchase Order and delivery.

**FUNDS AVAILABLE:**

\_\_\_\_\_  
David W. Malinowski, **Finance Director**

\_\_\_\_\_  
**Date**

\_\_\_\_\_  
Kenneth J. Filipiak, **City Manager**

\_\_\_\_\_  
**Date**

**APPROVED AS TO FORM:**

\_\_\_\_\_  
Joseph P. Szeman, **Law Director**

\_\_\_\_\_  
**Date**

**E. DELINQUENT PERSONAL PROPERTY STATEMENT**

\_\_\_\_\_, having been awarded a contract by City of Mentor; hereby affirms under oath, pursuant to Ohio Revised Code Section 5719.042, that at the time the bid was submitted, my company **was / was not** charged with delinquent personal property taxes on the General Tax List of Personal Property for \_\_\_\_\_ County, Ohio.

If such charge for delinquent personal property tax exists on the General Tax List of Personal Property for \_\_\_\_\_ County, Ohio, the amount of such due and unpaid delinquent taxes, including due and unpaid penalties and interest shall be set forth below.

This statement shall be incorporated into the Contract made between the City of Mentor and \_\_\_\_\_ and no payment shall be made with respect to any Contract unless such statement has been so incorporated as a part thereof.

Delinquent Personal Property Tax	\$ _____
Penalties	\$ _____
Interest	\$ _____

COMPANY

\_\_\_\_\_  
*Name, Title*

Subscribed in my presence, and sworn to before me, this \_\_\_ day of \_\_\_\_\_, 2019.

\_\_\_\_\_  
Notary Public

**F. AFFIDAVIT OF COMPLIANCE WITH OHIO REVISED  
CODE SECTION 3517.13**

STATE OF OHIO

COUNTY OF \_\_\_\_\_

\_\_\_\_\_ being duly sworn deposes and states as follows:

1. I am duly authorized to make the statements contained herein on behalf of \_\_\_\_\_ (“the Contracting Party”).
2. The Contracting Party is a/an (select one):
  - Individual, partnership, or other unincorporated business association (including without limitation, a professional association organized under Ohio Revised Code Chapter 1787), estate, or trust
  - Corporation organized and existing under the laws of the State of \_\_\_\_\_
  - Labor organization
3. I hereby affirm that the Contracting Party and each of the individuals specified in R.C. 3517.13(I) (with respect to non-corporate entities and labor organizations) or R.C. 3517.13(J) (with respect to corporations) are in full compliance with the political contribution limitations set forth in R.C. 3517.13(I) and (J), as applicable.
4. I understand that a false representation on this certification will incur penalties pursuant to 3517.992(R)(3).

Affiant further sayeth naught.

By: \_\_\_\_\_

Title: \_\_\_\_\_

SWORN TO BEFORE ME and subscribed in my presence this \_\_\_\_\_ day of \_\_\_\_\_, 2019.

\_\_\_\_\_  
Notary Public

My commission expires: \_\_\_\_\_

## **G. ESCROW WAIVER**

In accordance with a certain Contract between the City of Mentor, Mentor, OH, (hereinafter referred to as "the Owner") and \_\_\_\_\_, (hereinafter referred to as "the Contractor") it is mutually agreed by and between the parties hereto that because of the short-term duration of the within contract, no escrow account will be established pursuant to Sections 153.13, 153.14 and 153.63 of the Ohio Revised Code nor shall any interest be paid on any retainage.

### **CONTRACTOR:**

\_\_\_\_\_  
*Name, Title*

### **CITY OF MENTOR**

\_\_\_\_\_  
Kenneth J. Filipiak, City Manager



## VI. SPECIFICATIONS FOR THE PURCHASE OF DECORATIVE STREETLIGHTS

### A. GENERAL REQUIREMENTS

This project will involve purchasing approximately seventy-two (72), eighteen (18) Single Arm and fifty-four (54) Double Arm streetlight assemblies. The City of Mentor reserves the right to modify these amounts based on final spacing decisions, engineering design and budgetary constraints. The components of these lights (i.e., luminaire[s], arms and poles) must be fully compatible with one another.

1. Brand or Trade Name: Brand names, where mentioned in these specifications, are not intended to be restrictive, but rather to indicate the level of quality required by the City. In any instance where a brand name is mentioned, it is assumed that the phrase "or equal" shall follow.
2. Warranty: Bidder shall submit written conditions and periods of warranty with the bid proposal. A minimum five-year warranty is required for each bid item.
3. Delivery: The successful bidder will be required to deliver the equipment within the number of days as stated on the Proposal-Contract form. Deliveries of the material will be made to the 6645 Hopkins Road storage yard, or any other site within the City as designated by the Director of Public Works
4. Proposal (Bid) Bond: Section 3G of the Instructions to Bidders is hereby amended. A certified check or proposal bond in the amount of \$500.00 will be required.
5. Contract Bond: Section 20 of the Instructions to Bidders is hereby amended. A performance bond in the amount of \$500.00 will be required. The City of Mentor may elect to hold the bid deposit as a contract bond.

### B. MINIMUM REQUIREMENTS

These specifications detail minimum requirements acceptable to the City of Mentor. Should the manufacturer's current specifications exceed these, they shall be considered minimum and shall be furnished, and equipment and components included in the bid shall be stipulated.

Any and all parts not specifically mentioned in these specifications but which are required for proper and safe operation shall be furnished by the bidder and shall conform in strength, quality of material and workmanship to that provided by the industry in general. All items not specifically mentioned but which are standard factory items shall be furnished.

C. MATERIAL SPECIFICATIONS:

LUMINAIRE ASSEMBLY:

<b>QTY</b>	<b>DESCRIPTION</b>
18	SINGLE ARM: Holophane North Yorkshire Type Light Pole Assemblies  MPL2P50S50KASBKBG3SDS NYA23L6J17P08BKR270AY SLBHC96/ 1L68BKH BHDF/13200BK NYA17BRKWY4KITBK FGIUS-SBK AB-27-4 RFD 215276
54	DOUBLE ARM Holophane North Yorkshire Type Light Pole Assemblies  MSPL2P5050KASSB7SS BHDF13200BK BHC96/2CAL68BKH NYA12L6J171P08ABGBK R138A TRANSPO SPM4100XL YA17BRKWYKITBK FGIUS_S BK RFD307564
18	SINGLE LUMINAIRE: Memphis Tear Drop Teardrop LED 2 Series (MPL2): MPL2, 19,000 lumens; 5 COB's, 5000K CCT, Auto-sensing voltage (120 thru 277) 50/60 HZ, Black, Bowl glass and door, Type 3 Asymmetric Distribution, Quick Lock Stem Mount, 30" Diameter Deep Skirt for Cutoff Requirement.
54	DOUBLE LUMINAIRE: Memphis LED Pedestrian Series (MSPL2): MSPL2, LED Performance Package 50, 5000 Series CCT, Auto-Sensing (120-277V) 50/60 HZ, Quick Lock Stem Mount, Black, Shallow Asymmetric, Shallow Skirt For Cutoff Requirement (23" Dia), Boston Harbor Decorative Arm Fitter, 2.00 Nominal (2.38" OD), Black.
	* Boston Harbor Aluminum Decorative Roadway Arm (BHC): BHC, 96" Roadway Arm For 2 Units at 180, Cast Aluminum, Clamp for use with Sitelink SL6 or SL8 Shaft Styles, Black.

SINGLE ARM POLE:

<b>QTY</b>	<b>DESCRIPTION</b>
18	NORTH YORKSHIRE ALUMINUM POLE: <ul style="list-style-type: none"><li>• 23' Tall, L6J Sitelink Shaft with a 3"x5" Tenon, Receptacle Provision, 17" Diameter Base. Holophane Black.</li><li>• Sitelink Boston Harbor Roadway Arm, 96" Long for Mounting a Single Fixture, Tracnut included. Holophane Black.</li><li>• Boston Harbor Leveling Fitter with Quick Stem Mount. Holophane Black</li><li>• Break-away Kit consisting of 1" Transpo Couplings, Bearing Plate and Skirt. Holophane Black.</li></ul>

- GFI Receptacle with Small In-Use Weatherproof Cover. Holophane Black.

SINGLE ARM POLE (Continued):

- 1”X36” Anchor Bolts Included.

DOUBLE ARM POLE:

<b>QTY</b>	<b>DESCRIPTION</b>
------------	--------------------

54 NORTH YORKSHIRE ALUMINUM POLE:

- 17” Base (NYA): NYA, 12’, L6J SiteLink 6”, 17” Round Base for Sitelink, 3”X5” Tenon, Anchor Bolts, Galvanized Steel, Powder Coat Paint, Black.
- Transpo Non-Standard Breakaway Couplings 4100-XL. Catalog Number and Price is for a Set of four (4) Couplings and attachment Hardware. Work with NY17L6J (HS-1166-M1 BASE)
- NYA17BRKWYKITBK - Bearing Plate and Skirt, Black.
- Weatherproof Receptacle (FG): Small, In-Use Wet Location Cover, Black Height:138”. Orientation:0 deg.

BANNER ARM/SET

<b>QTY</b>	<b>DESCRIPTION</b>
------------	--------------------

144 BA24 L68 H 3 BK:

- Banner Arm Aluminum (BA): Top and Bottom Arm, 1 Top and bottom Arm Only, 24”, Sitelink Single Banner Arm, Large Tracnut for L6/8 Shafts, Half Sphere, ¾” Diameter, Black.

PLANTER ARM

<b>QTY</b>	<b>DESCRIPTION</b>
------------	--------------------

72 PBA18L68H4BK RFD205491:

- Sitelink Planter Arms, 18” Long, 1” Diameter Pipe with Half-sphere Finial, Eyebolt, Tracnuts included. Holophane Black.

## VII. PROPOSAL-CONTRACT FORM

The undersigned hereby proposes to furnish the City of Mentor, Ohio, the following items, in accordance with the specifications and upon the terms and conditions of this proposal or any part hereof is accepted as a contract by the City of Mentor.

Bid prices must include shipping to Mentor Municipal Maintenance Facility Freight On Board (FOB)

CONDITIONS: The Instructions to Bidders and the Specifications are a part of this contract as effectively as though they preceded in the signatures of the parties. This contract is not valid until accepted and signed by the City of Mentor.

ITEM #	DESCRIPTION	EST. QTY.	MATERIAL UNIT PRICE	TOTAL PRICE
1	<b>SINGLE ARM AND POLE COMPLETE ASSEMBLY:</b> SITELINK, North Yorkshire Type Light Pole Assemblies, PART #: MPL2P50S50KASBKBG3SDS NYA23L6J17P08BKRXXXY SLBHC96/1L68BKH BHDF/13200BK NYA17BRKWY4KITBK FGIUS-SBK AB-27-4 RFD215276 OR EQUAL	18	\$ _____	\$ _____
2	<b>DOUBLE ARM AND POLE COMPLETE, ASSEMBLY:</b> SITELINK, North Yorkshire Type Light Pole Assemblies, PART #: MSPL2P5050KASSB7SS BHDF13200BK BHC96/2CAL68BKH NYA12L6J171P08ABGBK R138A TRANSP0 SPM4100XL NYA17BRKWYKITBK FGIUS_S BK RFD307564 OR EQUAL	54	\$ _____	\$ _____
3	<b>BANNER ARM/SET</b> TOP AND BOTTOM ARM, 3/4" DIAMETER	144	\$ _____	\$ _____
4	<b>PLANTER ARM</b> 18" LONG, 1" DIAMETER PIPE	72	\$ _____	\$ _____
<b>TOTAL</b>				<b>\$ _____</b>

Warranty: \_\_\_\_\_

Delivery (days after receipt of Purchase Order): \_\_\_\_\_

## VIII. STATEMENT OF BIDDER QUALIFICATIONS

- 1) Years in business providing the goods or service requested in this bid \_\_\_\_\_
  - 2) Please list on a separate sheet(s), contracts with municipalities previously held, and now held. Please list by community name, contact person, address, phone number and scope of project (starting with the most recent).
  - 3) Is your company in satisfactory financial condition? Yes \_\_\_\_\_ No \_\_\_\_\_
  - 4) How many miles is your facility from the Mentor Municipal Center? \_\_\_\_\_
  - 5) Please list on a separate sheet(s) the equipment to be used in fulfilling this contract.
  - 6) Identify the project manager who will be assigned to this project and applicable years of experience managing comparable jobs.
- 

For the following questions, on a separate sheet, please describe in full the circumstances for any Yes answer.

- 7) Has your company had any business interruptions as a result of financial conditions in the past two (2) years? Yes \_\_\_\_\_ No \_\_\_\_\_
- 8) Has your company been rejected for a public contract despite being a low bidder for any reason? Yes \_\_\_\_\_ No \_\_\_\_\_
- 9) Has your company had any claims against or a performance bond cancelled? Yes \_\_\_\_\_ No \_\_\_\_\_
- 10) Has your company paid penalties or liquidated damages imposed as a result of delay on a public project? Yes \_\_\_\_\_ No \_\_\_\_\_
- 11) Has your company been found to have committed an unfair labor practice or any other employment/labor law violation in such areas as discrimination, prevailing wage, Workers' Compensation or OSHA? Yes \_\_\_\_\_ No \_\_\_\_\_
- 12) Has your company in the last three (3) years had a municipal contract cancelled or terminated? Yes \_\_\_\_\_ No \_\_\_\_\_

**STATEMENT OF BIDDER QUALIFICATIONS (continued)**

BIDDER NAME (print/type): \_\_\_\_\_

BIDDER ADDRESS: \_\_\_\_\_  
\_\_\_\_\_

BIDDER CONTACT: \_\_\_\_\_

BIDDER PHONE NUMBER: \_\_\_\_\_

BIDDER FAX NUMBER: \_\_\_\_\_

BIDDER E-MAIL: \_\_\_\_\_

Federal Tax Identification Number \_\_\_\_\_

State Tax Identification Number \_\_\_\_\_

# Specifications

## POST DESCRIPTION

The lighting post shall be all aluminum, one-piece construction, with a classic fluted base design. The patented SiteLink shaft profile shall consist of four mounting tracks and channels. The post shall be provided with (1) SiteLink Boston Harbour decorative roadway arm, 96" from post center to luminaire center, (1) Boston Harbour QSM fitter, (1) GFI receptacle with small, in-use weatherproof cover, and (1) one breakaway kit consisting of 1" transpo couplings, bearing plate and skirt.

## MATERIALS

The base shall be heavy wall, cast aluminum produced from certified ASTM 356.1 ingot per ASTM B-179-95a or ASTM B26-95. The shaft shall be extruded from aluminum, ASTM 6061 alloy. All hardware shall be stainless steel. Anchor bolts to be completely hot dip galvanized.

## DIMENSIONS

The post shall be 23'-0" in height with a Ø17" base. A hand hole shall be provided for access. An integral Ø3"x5" tall tenon shall be provided.

## INSTALLATION

The post shall use four L-type anchor bolts, to be installed on a 12" diameter bolt circle. A door shall be provided in the base for anchorage and wiring access. A grounding screw shall be provided inside the base opposite the door.

## FINISH

The entire pole assembly shall be standard Holophane black.

## LUMINAIRES

- Memphis Tear Drop LED 2 Series
- 19,000 Lumens, 5 COB's, 5000 Series CCT
- Auto-sensing Voltage (120-277V) 50/60 HZ, Black finish
- Type III Asymmetric, Bowl Glass and door, Quick Lock Stem Mount
- Ø30" Deep Skirt for Cutoff Requirement

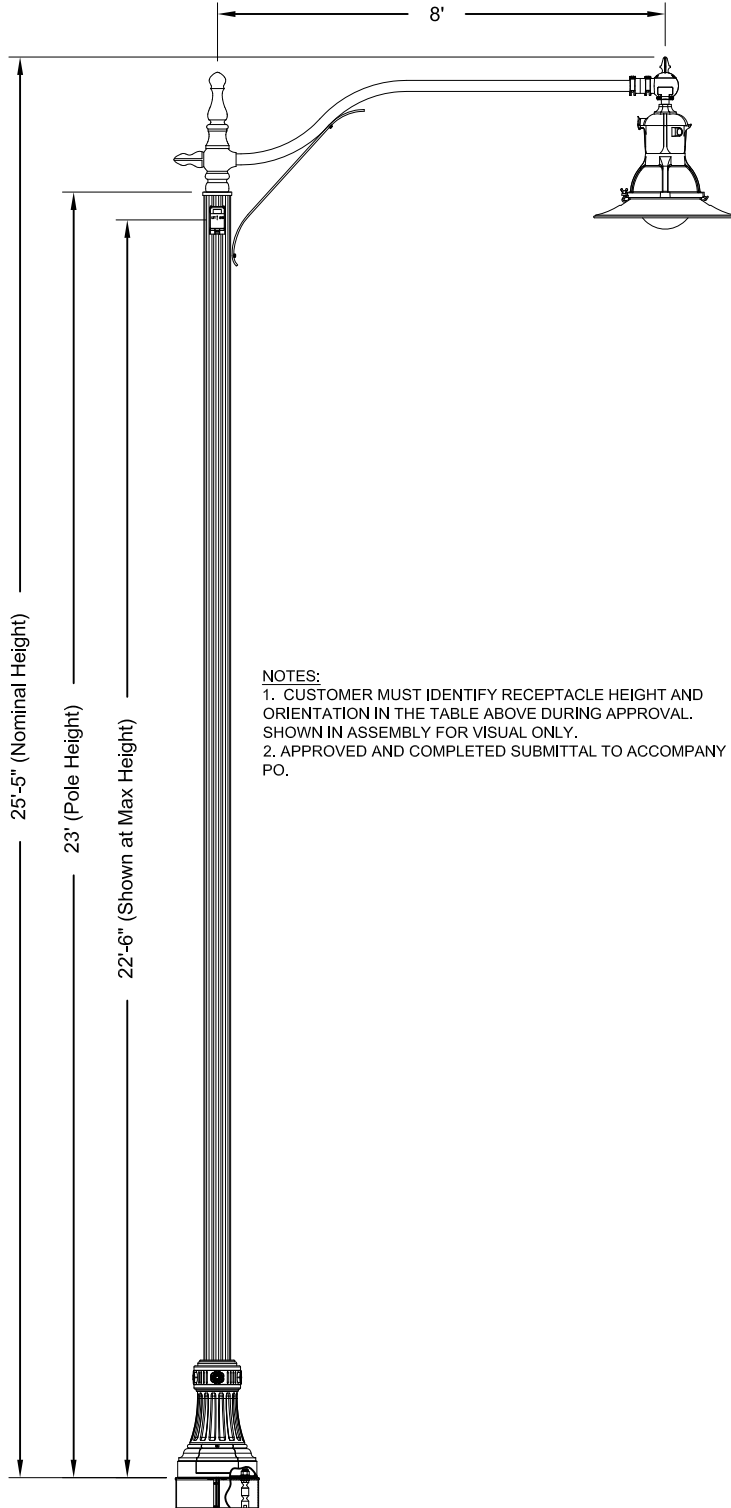

### NOTES:

1. CUSTOMER MUST IDENTIFY RECEPTACLE HEIGHT AND ORIENTATION IN THE TABLE ABOVE DURING APPROVAL. SHOWN IN ASSEMBLY FOR VISUAL ONLY.
2. APPROVED AND COMPLETED SUBMITTAL TO ACCOMPANY PO.

## Accessory Mounting Detail

	Orientation	Height
RECEPTACLE		

## Anchorage Detail

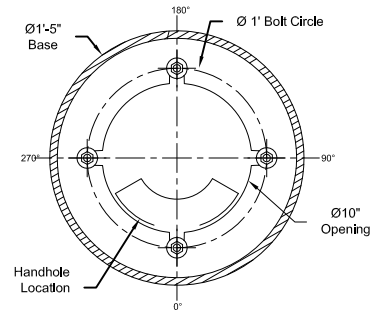

DO NOT USE TO SET ANCHOR BOLTS  
CONTACT CUSTOMER SERVICE FOR TEMPLATE

### Catalog #'s:

RFD215276

Pole: NYA23L6J17P08BK RXXXY

Anchor Bolts: AB-27-4

Breakaway Kit: NYA17BRKWY4KITBK

Breakaway Couplings: TRANSP0-SPM4100

Receptacle: FGIUS-SBKH

Post Top Arm: SLBHC96/1L68BKH

Fixture/Fitter: MPL2P50S50KASBKBG3SDS, BHDF13200BK

Customer Signature:

Date:



Mentor, Old Village  
Mentor, OH

ORDER #: 2293-14-10729-1

TYPE: NORTH YORKSHIRE

DRAWING #:

REVISION:

REVISION DATE:

TSG 009900

DRAWN: MAB

ORIGIN DATE: 11/11/16

PAGE: 1 of 1

THIS DRAWING, WHEN APPROVED, SHALL BECOME THE COMPLETE SPECIFICATION FOR THE MATERIAL TO BE FURNISHED BY HOLOPHANE ON THE ORDER NOTED ABOVE. A UNIT OF SIMILAR DESIGN MAY BE SUPPLIED, BUT ONLY AFTER APPROVAL BY THE CUSTOMER IN WRITING. ON POLE ORDERS AN ANCHOR BOLT TEMPLATE PRINT WILL BE SUPPLIED WITH EACH ANCHOR BOLT ORDER TO MATCH THE POLE PROVIDED. THIS PRINT IS THE PROPERTY OF HOLOPHANE AND IS LOANED SUBJECT TO RETURN UPON DEMAND AND UPON EXPRESS CONDITION THAT IT WILL NOT BE USED DIRECTLY OR INDIRECTLY IN ANY WAY DETRIMENTAL TO OUR INTERESTS, AND ONLY IN CONNECTION WITH MATERIAL FURNISHED BY HOLOPHANE.

# North Yorkshire Series Pole

Aluminum, SiteLink Straight L6J Shaft

Tenon: Ø3"x5"

(1)Receptacle Provision

Breakaway Kit: Bearing Plate, Breakaway Couplings, Nuts, Washers, Skirt

Finish: Holophane Black

## Boston Harbor Roadway Arm

Twin, 96" from Luminaire Center to Luminaire Center

Black Finish

## Boston Harbor Decorative Arm Fitter

Quick Stem Hub, Black finish

## Memphis LED Pedestrian Series

LED Performance Pkg 50 -

5000 Series CCT -

AutoSensing Voltage (120-277V) -

Quick Lock Stem Mount -

Shallow Asymmetric optics -

Ø23" Shallow Skirt for Cutoff Requirement -

Black finish -

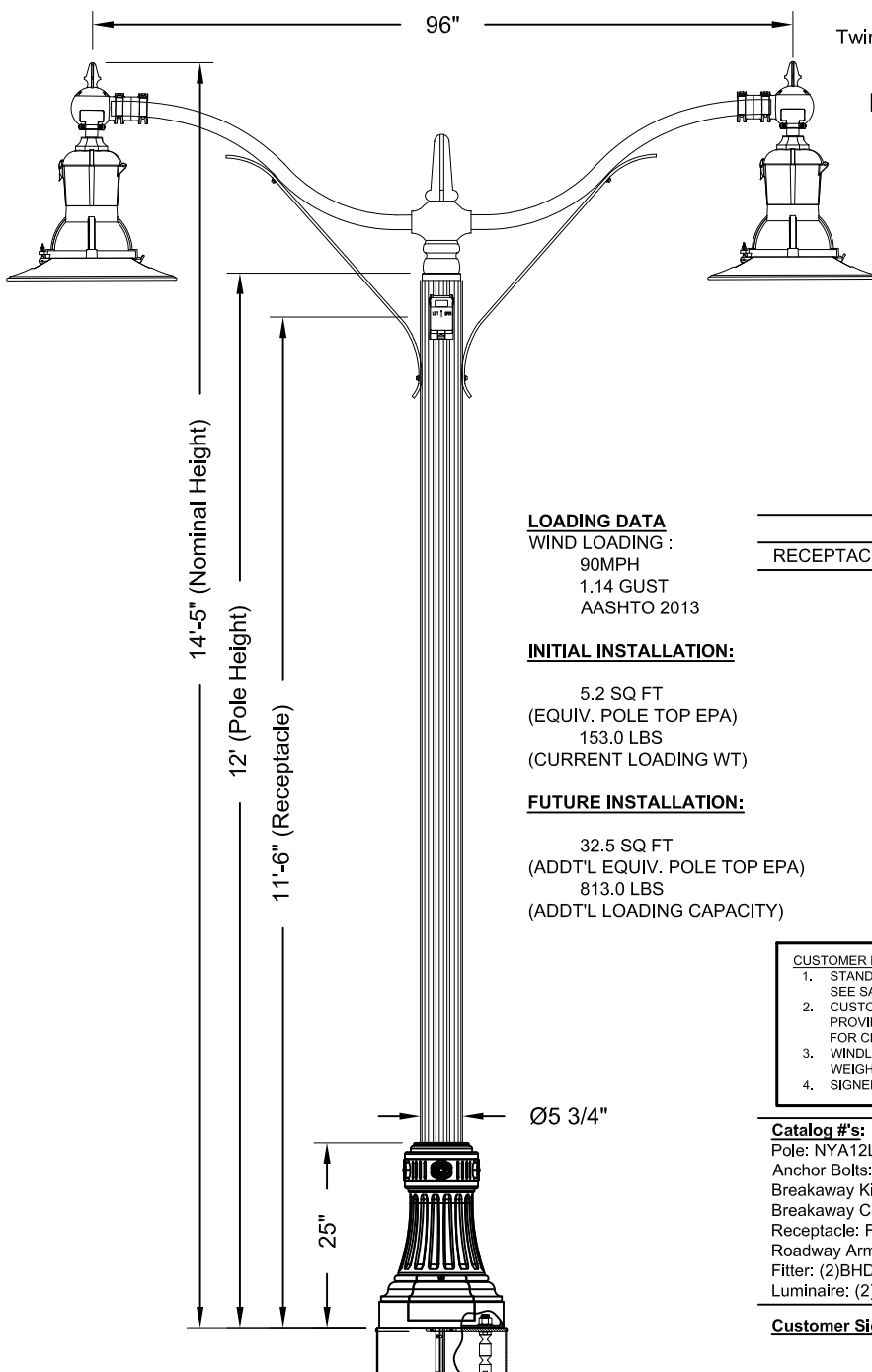

### LOADING DATA

WIND LOADING :

90MPH

1.14 GUST

AASHTO 2013

### INITIAL INSTALLATION:

5.2 SQ FT

(EQUIV. POLE TOP EPA)

153.0 LBS

(CURRENT LOADING WT)

### FUTURE INSTALLATION:

32.5 SQ FT

(ADDT'L EQUIV. POLE TOP EPA)

813.0 LBS

(ADDT'L LOADING CAPACITY)

### Accessory Mounting Detail

RECEPTACLE	Orientation	Height
	0°	11'-6"

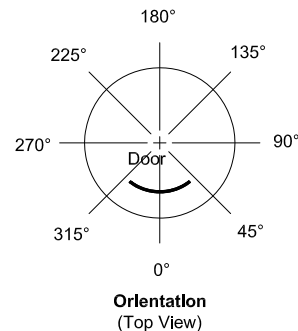

### CUSTOMER NOTES:

- STANDARD SPECS NOT SHOWN HERE MAY BE SEEN ON CUT SHEETS (PLEASE SEE SALES).
- CUSTOMER MUST VERIFY ACCESSORY HEIGHTS & ORIENTATIONS AND PROVIDE PRIOR TO PRODUCTION. ACCESSORIES MAY BE ROTATED IN VIEW FOR CLARITY.
- WINDLOADING PROVIDED BASED ON ASSEMBLY SHOWN. ANY CHANGES TO WEIGHT/EPA, MAY NEED TO BE VALIDATED BY HOLOPHANE ENGINEERING.
- SIGNED APPROVAL TO ACCOMPANY PO.

### Catalog #'s:

Pole: NYA12L6J17P08BK R138A RFD307564

Anchor Bolts: AB-27-4

Breakaway Kit: NYA17BRKWYKITBK

Breakaway Couplings: TRANSP0 SPM4100XL RFD307564

Receptacle: FGIUS-SBKH

Roadway Arm: BHC96/2CAL68BKH

Fitter: (2)BHDF13200BK

Luminaire: (2)MSPL2P5050KASSB7SS

Customer Signature:

Date:



## Mentor Old Village, Phase 2

Mentor, OH

ORDER #: 2293-16-11819-1

TYPE: DOUBLES

DRAWING #:

REVISION: 1

REVISION DATE: 08/20/19

TSG 011597

DRAWN: MAB

ORIGIN DATE: 07/25/19

PAGE: 1 of 1

THIS DRAWING, WHEN APPROVED, SHALL BECOME THE COMPLETE SPECIFICATION FOR THE MATERIAL TO BE FURNISHED BY HOLOPHANE ON THE ORDER NOTED ABOVE. A UNIT OF SIMILAR DESIGN MAY BE SUPPLIED, BUT ONLY AFTER APPROVAL BY THE CUSTOMER IN WRITING. ON POLE ORDERS AN ANCHOR BOLT TEMPLATE PRINT WILL BE SUPPLIED WITH EACH ANCHOR BOLT ORDER TO MATCH THE POLE PROVIDED. THIS PRINT IS THE PROPERTY OF HOLOPHANE AND IS LOANED SUBJECT TO RETURN UPON DEMAND AND UPON EXPRESS CONDITION THAT IT WILL NOT BE USED DIRECTLY OR INDIRECTLY IN ANY WAY DETRIMENTAL TO OUR INTERESTS, AND ONLY IN CONNECTION WITH MATERIAL FURNISHED BY HOLOPHANE.