

City of Mentor
Bid Set

**LAK - Hopkins Road Resurfacing
City of Mentor
Federal Project Number E200(439)
PID # 111567
September 2020**

Disadvantaged Business Enterprise (DBE) Requirement.
DBE participation goals (subcontracts, materials, supplies) have been set on this project for those certified as DBEs pursuant to Title 23, U.S.C. section 140(c) and 49 CFR, Part 26, and where applicable qualified to bid with ODOT under Chapter 5525 of the ORC. The DBE Goal for this project is 7% .



Prepared under the supervision of
Allen E. Pennington, Ohio P.E. 63942
Date 8/18/2020
Civil Engineer – Traffic,
Office of the Mentor City Engineer

Approved By:
David A. Swiger, P.E.
City Engineer
Date 8/19/20

CITY OF MENTOR OFFICIALS

ADMINISTRATION

Kenneth J. Filipiak, City Manager

David W. Malinowski, Finance Director

Joseph P. Szeman, Law Director

David A. Swiger, City Engineer

Matthew Schweikert, Director of Public Works

Kenneth Kaminski, Director of Parks, Recreation and Public Facilities

Kevin Malacek, Economic Development Director

Ken Gunsch, Chief of Police

Robert Searles, Fire Chief

COUNCIL

Bruce R. Landeg, President

Matthew E. Donovan, Vice President

Sean P. Blake

Janet A. Dowling

John A. Krueger

Ray Kirchner

Scott J. Marn

Julie Schiavoni, Clerk

ADVERTISEMENT FOR BIDS/PUBLIC NOTICE TO BIDDERS

Sealed proposals will be received at the Purchasing Department, City of Mentor, 8500 Civic Center Boulevard, Mentor, Ohio until 12 noon on September 25, 2020 and will be opened and read immediately thereafter for the following roadway resurfacing project:

**LAK - Hopkins Road Resurfacing
Federal Agreement Number E200(439)
OPINION OF PROBABLE CONSTRUCTION COST: \$900,000.00
COMPLETION DATE: 6/18/2021**

Bids must be in accordance with specifications advertised on the City of Mentor website: www.cityofmentor.com/category/rfp or RFP's will be available for pick-up at the Purchasing Office between the hours of 8 AM and 5 PM Monday – Friday.

Only those contractors which are prequalified for work by ODOT pursuant to Section 102.01 of the CMS will be eligible to submit bids for the construction of this project. Each bid must be accompanied by a certified or cashier's check in the amount of 10% of the amount bid, an irrevocable letter of credit in the amount of 10% of the amount bid or an original bond in the amount of 100% of the amount bid per ORC 153.54 and 153.571.

Disadvantaged Business Enterprise (DBE) Requirement. DBE participation goals (subcontracts, materials, supplies) have been set on this project for those certified as DBEs pursuant to Title 23, U.S.C. section 140(c) and 49 CFR, Part 26, and where applicable qualified to bid with ODOT under Chapter 5525 of the ORC. The DBE Goal for this project is 7% .

Record Retention: As the LPA, ODOT or the United States Government may legitimately request from time to time, the Contractor agrees to make available for inspection and/or reproduction by the LPA, ODOT or the United States Government, all records, books, and documents of every kind and description that relate to this contract.

BY ORDER OF

Kenneth J. Filipiak, City Manager

Publish: *News-Herald*

TABLE OF CONTENTS

	<u>Page No.</u>
Title Page	i
Officials Page	ii
Advertisement for Bids/Public Notice to Bidders	iii
Table of Contents	iv - vi
SECTION 1	
<u>BID DOCUMENTS AND BID FORMS</u>	
Instructions to Bidders	BD.1 - BD.7
Prices to Include	BD.8 - BD.11
<u>**ALL BID FORMS SHALL BE COMPLETED AND SUBMITTED WITH BID**</u>	
Form of Non-collusion Affidavit	BF.1
Corporate Resolution	BF.2
Supplemental Bond Acknowledgement	BF.3
Insurance Agent Affidavit	BF.4
Proposed Subcontractors	BF.5
Experience Record	BF.6
Bid Security	BF.7
Bidder Qualifications	BF.8 – BF.9
Proposal Forms	BF.10 - BF.11
Signature Page (BF.11)	SEE BELOW
Buy America Certification	BF.12
ALL BIDS SUBMITTED <u>MUST INCLUDE</u> THE REQUIRED BID DOCUMENTS AND A PROPERLY EXECUTED SIGNATURE PAGE (BF.11)	
SIGNATURE PAGE AVAILABLE <u>ONLY</u> BY CONTACTING VERONICA FETSKO, FETSKO@CITYOFMENTOR.COM OR 440-974-5776	
SECTION 2	
<u>CONTRACT FORMS</u>	
Notice of Award	CF.1
Contract, Certificate of Fiscal Officer and Certificate of Legal Counsel	CF.2 - CF.3
Contract Bond, Certificate of Insurance, Certificate of Worker's Comp.	CF.4
Delinquent Personal Property Statement	CF.5
Affidavit of Compliance with ORC Section 3517.13 (Political Contribution Limitations)	CF.6
Escrow Waiver	CF.7
Notice to Proceed	CF.8
Notifications, Certifications, Affidavits Unresolved Findings of Recovery	N.1

SECTION 3 GENERAL CONDITIONS, EJCDC No. 1910-8 (1996) (Removed)

SECTION 4 SUPPLEMENTARY CONDITIONS SC.1 - SC.4

SECTION 5 SPECIFICATIONS

DIVISION 1 - GENERAL REQUIREMENTS

01010 SUMMARY OF WORK
01020 GENERAL REGULATIONS AND PERMITS
01038 SAMPLING AND TESTING
01041 PRE-CONSTRUCTION VIDEO TAPE DOCUMENTATION
01051 ADDITIONAL WORK, OVERTIME
01061 SHOP DRAWINGS AND SUBMITTALS
01066 TEMPORARY WATER AND DISTRIBUTION
01080 FIRST AID
01091 ENVIRONMENTAL PROTECTION
01099 FINAL COMPLIANCE AND SUBMITTALS

DIVISION 2 - SITE CONSTRUCTION

02235 COMPACTED GRANULAR BACKFILL
02520 ASPHALT CONCRETE PAVING AND MATERIALS

	<u>Page No.</u>
SECTION 6 <u>STANDARD SPECIFICATIONS</u>	
ODOT Specifications	SS.1
SECTION 7 <u>SPECIFIC PROJECT REQUIREMENTS</u>	SR.1 – SR.8
SECTION 8 <u>WAGE RATES</u>	PW.1
SECTION 9 <u>TYPICAL SECTIONS AND DETAILS</u>	
Location Map	M-1
Details	A-1 – A-7
Typical Section	T-1
Stationing Plans	1-3
 <u>APPENDIX</u>	
Quantity Calculations Spreadsheet (For informational purposes only)	
ODOT LPA Federal Template	
ODOT Construction and Material Specifications – Section 100	

SECTION 1
BID DOCUMENTS AND BID FORMS

INSTRUCTIONS TO BIDDERS

PART 1 GENERAL

- 1.1 Sealed bids shall be received by the Owner at the location specified and until the time and date specified in the Advertisement for Bids/Public Notice to Bidders.
- 1.2 Only those contractors which are prequalified for work by ODOT pursuant to Section 102.01 of the CMS will be eligible to submit bids for the construction of this project.
- 1.3 Each bid shall contain the full name and address of each person or company interested in said bid. If no other person be so interested, the Bidder shall distinctly so state the fact.
- 1.4 Bid forms must be completed in ink or by typewriter. Any corrections to the bid forms prior to submission must be initialed by the person signing the bid. Failure to submit any bid form(s) or other required document(s) may be cause for rejection of the bidder's bid at the sole discretion of the Owner.
- 1.5 Bids by Corporations must be executed in the corporate name by the President, Vice President, or other officer accompanied by evidence of authority to sign and the corporate seal must be affixed and attested by the Secretary on the Corporate Resolution form.
- 1.6 Bids by partnerships must be executed in the partnership name and signed by a partner, whose title must appear under the signature.
- 1.7 All names must be typed or printed below the signature.
- 1.8 The bid shall contain an acknowledgment of receipt of all Addenda.
- 1.9 If a Bidder wishes to withdraw his bid prior to the opening of bids, he shall state his purpose in writing to the Owner before the time fixed for the opening, and when reached it shall be handed to him unread.
- 1.10 After the opening of bids, no Bidder may withdraw his bid for a period of 60 days.

PART 2 EXAMINATION OF CONTRACT DOCUMENTS AND SITE

- 2.1 Before submitting a bid, each Bidder must
 - A. Examine the Contract Documents thoroughly. Any reference to the plans or as per plan refers to the sheets included in Section 9 of this document.
 - B. Visit the site to familiarize himself with local conditions pursuant to Section 102.05 of the ODOT CMS.

- C. Familiarize himself with Federal, State, and local laws, ordinances, rules, and regulations that may in any manner affect cost, progress, or performance of the work.
 - D. Study and carefully correlate Bidder's observations with the Contract Documents.
- 2.2 Reference is made to the Specific Project Requirements for the identification of any reports of investigations and tests of subsurface and latent physical conditions at the site or otherwise affecting cost, progress or performance of the work which have been relied upon by the Engineer in preparing the drawings and specifications. Owner will make copies of such reports available to any Bidder requesting them if not made available with the bid documents. These reports are not guaranteed as to accuracy or completeness; nor are they part of the Contract Documents. Before submitting his bid each Bidder will, at his own expense, make such additional investigations and tests as the Bidder may deem necessary to determine his bid for performance of the work in accordance with the time, price and other terms and conditions of the Contract Documents.
- 2.3 Upon request, the Owner will provide each Bidder access to the site to conduct such reasonable investigations and tests as each Bidder deems necessary for submission for his bid.
- 2.4 The lands upon which the work is to be performed, rights-of-way for access thereto, and other lands designated for use by Bidder in performing the work are identified on the Drawings.
- 2.5 The submission of a bid will constitute an incontrovertible representation by the Bidder that he has complied with every requirement of this section and that the Contract Documents are sufficient in scope and detail to indicate and convey understanding of all terms and conditions for performance of the work.

PART 3 ESTIMATED QUANTITIES

- 3.1 In Unit Price Contracts, the quantities of the work itemized in the bid are approximate only and the bidders are hereby notified that the estimated quantities made by the Engineer are merely for the guidance of the Owner in comparing on a uniform basis all bids received for the work.
- 3.2 The contract quantities, where itemized, are based on plan horizontal and vertical dimensions unless otherwise specified. It is the Contractor's responsibility to verify and determine actual quantities of materials such as pipe, pavement, subgrade, etc. in his ordering materials.
- 3.3 Payments, except for lump sum contracts and except for lump sum items in unit price contracts, will be made to the Contractor only for the actual quantities of work performed or materials furnished in accordance with the plans and specifications. It is understood that the scheduled quantities of work to be done and materials to be furnished for items labeled as "Contingency" may be increased or diminished by any amount and the awarded quantity of all other items may be increased or diminished up to 15% without in any way invalidating the bid unit prices.

- 3.4 The successful Bidder will be required to furnish the Owner with a complete breakdown of the lump sum bid items, to the satisfaction of the Engineer/Architect, before signing the Contract documents.

PART 4 CONTRACTOR'S QUALIFICATION

- 4.1 Bidder shall provide information relating to similar projects completed within the past 5 years and shall include a list of projects currently under construction including status and contact person. Bidders experience shall demonstrate capabilities to undertake this type of project.
- 4.2 Bidder shall own, have rental or lease agreements for, or otherwise have readily available any and all equipment and tools necessary for proper execution of the work. The Owner reserves the right to request lists of equipment or tools available for the project including sources.
- 4.3 Bidder shall provide pertinent information to the Owner relative to any pending suits or outstanding liens. If no information is provided by the Bidder, the Owner shall assume that any such suits or liens do not exist.
- 4.4 The Owner may require similar information on any or all subcontractors proposed by the Bidder.

PART 5 SUBCONTRACTORS

- 5.1 The Bidder shall state on the appropriate bid form the names of all Subcontractors proposed and the items of work they are to be assigned. All work not assigned to a Subcontractor shall be assumed by the Owner to be performed by the Bidder.
- 5.2 The successful Bidder shall not subcontract work totaling more than 50% of the total contract.
- 5.3 The Owner reserves the right to approve all subcontractors proposed by the Bidder. If the Owner, after due investigation, rejects the use of a proposed subcontractor, the apparent successful Bidder may either submit an acceptable substitution without increase in bid price or decline substitution and withdraw his bid without sacrificing his bid security. Any listed subcontractor to whom the Owner does not make written objection prior to award of contract, shall be deemed acceptable to the Owner.
- 5.4 Requests for changes of Subcontractor by the Bidder after the award shall be subject to the Owner's approval and shall not change the contract bid prices.
- 5.5 No contractor shall be required to employ any Subcontractor, person or organization against whom he has reasonable objection.

5.6 Disadvantaged Business (DBE) Requirement. DBE participation goals (subcontracts, materials, supplies) have been set on this project for those certified as DBE's in accordance with 49 CFR, Part 26, and qualified to bid with ODOT under Chapter 5525 of the Ohio Revised Code. Contractor's approved DBE Affirmation Forms shall be submitted with bid.

PART 6 BID REVIEW BY OWNER

6.1 The Owner reserves the right to reject any and all bids according to Sections 102.14 and 103.01 of the ODOT CMS.

6.2 All extensions and totals of unit prices and quantities submitted as part of the bid shall be considered informal until verified by the Owner. All bids must be made on the forms contained herein and the bid prices must be written therein, in figures only. Unit prices shall be separately written for "Unit Price Labor," "Unit Price Material," and "Total Unit Price" for each item listed. Should an error in addition and/or multiplication be determined while checking the Contractor's math and verifying his total bid, the "Unit Price Labor" and the "Unit Price Material" figures shall govern in determining the correct "Total Unit Price" and the correct "Item Total." Each bidder must bid on all Items contained in the Bidding Forms. All bids not in conformity with this notice may be considered informal and may be rejected.

6.3 In evaluating bids, the Owner may consider:

- A. (Removed)
- B. (Removed)
- C. Completeness of all bid forms and bid requirements.
- D. The award will be based on the lowest responsive bid considering the sum of the base bid.
- E. (Removed)
- F. (Removed)
- G. Whether or not the bid package complies with the prescribed requirements.
- H. Any other matter allowed by law or local ordinance or resolution.

6.4 (Removed)

6.5 (Removed)

6.6 (Removed)

PART 7 BID SECURITY

7.1 Each bid must be accompanied by a certified or cashier's check in the amount of 10% of the amount bid, an irrevocable letter of credit in the amount of 10% of the amount bid or an original bond in the amount of 100% of the amount bid per ORC 153.54 and 153.571. The certified or cashier's check, or irrevocable letter of credit shall be from a financial institution authorized to transact business in the State of Ohio and acceptable to the Owner. The bond shall be underwritten by a Surety Company authorized to transact business in the State of Ohio having an Ohio agent and listed on the most current Department of the Treasury Circular 570, "Surety Companies Acceptable on Federal Bonds." The bond shall be a "Bid Guarantee and Contract Bond" ("rollover bond") per O.R.C. sections 153.54 and 153.571 submitted for the full amount of the bid including all alternates, if any.

If bid security is made by bond, the Bidder and his Surety shall sign the Supplemental Bond Acknowledgement form and submit with his bid.

7.2 The certified or cashier's check, irrevocable letter of credit, or bond shall be made payable to the Owner and shall serve as a guarantee that in the event the bid is accepted and a contract is awarded to the successful Bidder, the contract will be executed by the bidder including any certifications, certificates or additional bonds required by the contract.

7.3 Failure on the part of the successful Bidder to execute the contract documents will cause the certified or cashier's check, irrevocable letter of credit, or bond to be forfeited to the Owner as damages.

A. If the Owner awards the contract without rebidding, the Bidder (and the Surety on his bond if a bond was submitted) shall be liable to the Owner for a penal sum not to exceed the difference between the low bid and the next lowest bidder or 10% of the amount of the bid, whichever is less.

B. If the Owner does not award the Contract to the next lowest Bidder, but resubmits the project for bidding; the Bidder (and the Surety on his bond if a bond was submitted) shall be liable to the Owner for a penal sum not to exceed the costs in connection with the resubmission of bids or 10% of the amount of the bid, whichever is less.

7.4 Checks or letters of credit for bid security of all bidders will be returned in the manner and timeframe stipulated in the Ohio Revised Code.

PART 8 CONTRACT BOND

- 8.1 As security for faithful performance and payment of all obligations under the Contract, the Owner shall require and the successful Bidder shall furnish either:
- A. "Bid Guarantee and Contract Bond" (AKA "rollover bond") per O.R.C. sections 153.54 and 153.571.
 - B. Contract Bond per Ohio Revised Code Sections 153.54 and 153.57, in the amount of 100% of the Contract Price. The Contractor and his Surety shall sign the Supplemental Bond Acknowledgement form and submit with the Contract forms.
- 8.2 The bond shall be underwritten by a Surety Company authorized to transact business in the State of Ohio having an Ohio agent and listed on the most current Department of the Treasury Circular 570, "Surety Companies Acceptable on Federal Bonds."
- 8.3 The contract bond shall cover correction of the work for the period stated in the specifications and the correction period shall start upon Final Acceptance of the entire project and final payment by the Owner.
- 8.4 Nothing in the performance of the Engineer's service to the Owner in connection with this project shall in any way imply any undertaking for the benefit of the successful Bidder, its subcontractor(s), or the surety of any of them.

PART 9 AWARD AND EXECUTION OF CONTRACT

- 9.1 After the Owner's legislative body awards the project, the successful bidder will receive the unsigned contract documents. Within 10 days after their receipt, the successful Bidder shall sign and deliver to the Owner said contract documents including any certifications, certificates, or additional bonds required by the contract.
- 9.2 The Owner shall execute the Contract within 60 days after the day of the bid opening. When necessary and by mutual consent between the Owner and the Successful Bidder, this 60-day period may be extended.
- 9.3 The date of the Owner's signature on the Contract Agreement shall be the effective contract date.
- 9.4 The Owner shall execute and deliver to the successful Bidder two (2) sets of fully executed contract documents.

PART 10 INSURANCE

- 10.1 Verification of limits for public liability, property damage, automobile, Worker's Compensation, or any other insurance required by the provisions of this Contract must be submitted to the Owner prior to execution of the Contract.
- 10.2 All insurance shall be endorsed so that it cannot be cancelled or non-renewed for any reason in less than 30 days after a written notice of such proposed action by the insurer is given to the owner. The cancellation clause on the Certificate(s) of Insurance shall read as specified in the Supplementary Conditions and failure to submit an insurance certificate and/or policy endorsement verifying same shall be reason for the Owner to consider the Contractor non-responsive in complying with the requirements for contract execution and may be cause for forfeiture of the Bid Security to Owner.
- 10.3 The Contractor's Liability Insurance policy(s) shall be endorsed such that limits are on a Per Project basis.
- 10.4 The Contractor shall also provide an Owner's and Contractor's Protective Policy.

PART 11 NON-COLLUSION AFFIDAVIT

- 11.1 Each bid must be accompanied by a completed Noncollusion Affidavit provided within the contract documents.
- 11.2 Where there is reason to believe collusion or combination among bidders exists, the Owner reserves the right to reject the bid of those concerned.

PART 12 (REMOVED)

PART 13 ORIGINAL DOCUMENTS

- 13.1 All bid forms, contract forms, bonds and any other bid documents or contract documents requiring signatures shall be submitted with original signatures. No photo copies or faxed copies of signed documents shall be accepted.

END OF SECTION 4/2015

PRICES TO INCLUDE

PART 1 GENERAL

Any work shown on the plans or required in the specifications but not paid for separately as a bid item shall be included in the cost of other bid items. The amount bid for each bid item shall include the following:

- 1.1 All labor, materials, tools, equipment and transportation necessary for the proper execution of the work in accordance with the contract documents.
- 1.2 All assistance required by the Engineer to verify compliance with the contract documents, including measuring for final pay quantities.
- 1.3 Project coordination and scheduling.
- 1.4 All provisions necessary to protect workers, the general public and property along the work in accordance with the contract documents.
- 1.5 Reimbursement to Owner for costs for re-inspection or retesting of any work not installed in compliance with the contract documents.
- 1.6 Maintaining traffic.
- 1.7 Mobilization.
- 1.8 Bonds and Insurances (including “per project aggregate” limit endorsement, “Owner/Contractor Protective Policy,” “All Risk Builder’s Risk Insurance,” and/or “Installation Floater Insurance,” as required; **and any endorsements to fully comply with all contract requirements**).
- 1.9 Construction staking of the improvements.
- 1.10 All erosion control measures as needed.
- 1.11 Restoration, seeding and mulching.

PART 2 ITEMS

All work proposed by this contract shall be quantified and paid for in accordance with the pertinent ODOT specification except as specifically altered by other provisions of this contract.

CONTRACT A

2.1 PAVEMENT PLANING, (BITUMINOUS), AS PER PLAN

Basis of Payment

Payment shall be made in accordance with ODOT Item 254 and the attached construction drawings and shall also include all General Items 1.1 to 1.11 above. Planing depths shall be as specified by the engineer for each street. See quantity worksheets in section 01010 and the typical section for specific bituminous planning depths.

2.2 TACK COAT, TRACKLESS

Basis of Payment

The unit price stipulated per gallon of tack coat shall be for the trackless tack coat as required for each of the separate application rates as defined in the typical sections.

2.3 ITEM 253 PAVEMENT REPAIR, AS PER PLAN

This item shall be performed per Item 253 with the following modifications:

A quantity of this item shall be provided for use as directed by the engineer. This item shall consist of cutting and removing 7" of deteriorated pavement and subbase material. Failure to remove the specified 7" will require the contractor to return and remove materials to the appropriate depth. Contractor shall place 7" of 301 asphalt concrete base, PG64-22. The maximum compacted depth of any one layer shall be 4". It is not the intent to repair every deteriorated area within the project. After milling, the contractor shall examine and pre-mark all areas requiring full depth repair. Upon completion of marking, the contractor shall contact the engineer for review of the proposed areas. Within two working days of notification, the engineer will review areas and add or delete areas at his discretion. No paving/full depth repair work shall occur until the contractor has been notified to proceed by the engineer. Failure of the contractor to follow this procedure may result in the City withholding payment for any work performed.

Basis of Payment

The unit price stipulated shall be based upon the actual number of square yards of pavement removed and replaced to the limits designated by the engineer. Payment is full compensation for all labor, equipment, incidentals and materials, cutting, removal and disposal of existing pavement and base necessary to complete this work. Any excavation in excess of the specified depth shall be restored at the contractor's expense.

2.5 ITEM 611, MONUMENT BOX ADJUSTED TO GRADE, AS PER PLAN

Basis of Payment

The unit price bid shall include identifying monument pin location and coring of asphalt and concrete to reestablish pin location to finished grade. Core shall be fitted with a casting similar in composition to existing pin's casting.

2.6 Item 442 – Asphalt Concrete Surface Course, 12.5mm, Type A (448), PG 70-22M, As Per Plan

The coarse virgin aggregate for this item shall be limited to a blend of air-cooled blast furnace slag (ACBFS) or Trap Rock from Ontario and limestone. The Contractor shall use a minimum 60% of ACBFS or Trap Rock from Ontario with limestone comprising the remaining percentage. At least 50% of fine virgin aggregate for this item shall be limited to ACBFS or Trap Rock from Ontario.

When ACBFS is used for a fraction of the coarse aggregate, provide a total asphalt binder content greater than or equal to 6.2 percent. If ACBFS makes up 100% of the coarse aggregate, apply the binder content requirements of C&MS 442.

FORM OF NONCOLLUSION AFFIDAVIT

STATE OF _____)

) SS

COUNTY OF _____)

_____, being first duly sworn, deposes and says
(Individual Name)

that he/she is _____ of _____
(Sole Owner, Partner, President, Secretary, etc.) (Corporation Name)

the party making the proposal or bid; that such bid is genuine and not collusive or sham; that said Bidder has not colluded, conspired, connived, or agreed, directly or indirectly with any Bidder or person, to put in a sham bid, or that such other person shall refrain from bidding, and has not in any manner, directly or indirectly sought by agreement or collusion or communication or conference, with any person, to fix the bid price of affiant or any other Bidder, or to fix any overhead, profit, or cost element of said Bid price, or of that of any other Bidder, or to secure any advantage against the Owner, or any person interested in the proposed Contract; and that all statements contained in said proposal or bid are true; and further, that such Bidder has not, directly or indirectly submitted this Bid, or the contents thereof, or divulged information or data relative thereto to any association or to any member or agent thereof.

Affiant

Subscribed and sworn to before me this ____ day of _____, 20 ____.

Notary Public

My Commission Expires: _____

PROPOSED SUBCONTRACTORS

The Bidder is required to state in the spaces provided below, the Subcontractors he proposes to use to accomplish the work under this Contract. The items and specific amounts of work assigned to each listed Subcontractor shall also be outlined. Duplicate this sheet as needed.

1. Name: _____
Address: _____
City/State/Zip: _____
Description: _____
Phone: () _____ Amount: \$ _____ % of Contract: _____

2. Name: _____
Address: _____
City/State/Zip: _____
Description: _____
Phone: () _____ Amount: \$ _____ % of Contract: _____

3. Name: _____
Address: _____
City/State/Zip: _____
Description: _____
Phone: () _____ Amount: \$ _____ % of Contract: _____

4. Name: _____
Address: _____
City/State/Zip: _____
Description: _____
Phone: () _____ Amount: \$ _____ % of Contract: _____

5. Name: _____
Address: _____
City/State/Zip: _____
Description: _____
Phone: () _____ Amount: \$ _____ % of Contract: _____

EXPERIENCE RECORD

The Bidder is required to state the character of previous work, give references, and such other detailed information as will enable the Owner to determine capability, responsibility, experience, skill, and financial standing. Provide data for the last five (5) years. Duplicate this sheet as needed. **Information submitted in an alternate format MUST contain all the information requested on this page.**

Project Name: _____

Description/Scope of Bidder's Work: _____

On this project you were a ___ Prime Contractor **OR** ___ Sub Contractor to _____

Your Contract or
Subcontract Amount: \$ _____

Total Project Cost: \$ _____

% Complete (if in progress) ___% or Date Completed (if complete): _____

Project Owner: _____

Owner Contact: _____ Phone: (____) _____

Engineer/Arch. Firm: _____

Engineer/Arch. Contact: _____ Phone: (____) _____

Your Bonding Company on this project (if any): _____

Project Name: _____

Description/Scope of Bidder's Work: _____

On this project you were a ___ Prime Contractor **OR** ___ Sub Contractor to _____

Your Contract or
Subcontract Amount: \$ _____

Total Project Cost: \$ _____

% Complete (if in progress) ___% or Date Completed (if complete): _____

Project Owner: _____

Owner Contact: _____ Phone: (____) _____

Engineer/Arch. Firm: _____

Engineer/Arch. Contact: _____ Phone: (____) _____

Your Bonding Company on this project (if any): _____

Project Name: _____

Description/Scope of Bidder's Work: _____

On this project you were a ___ Prime Contractor **OR** ___ Sub Contractor to _____

Your Contract or
Subcontract Amount: \$ _____

Total Project Cost: \$ _____

% Complete (if in progress) ___% or Date Completed (if complete): _____

Project Owner: _____

Owner Contact: _____ Phone: (____) _____

Engineer/Arch. Firm: _____

Engineer/Arch. Contact: _____ Phone: (____) _____

Your Bonding Company on this project (if any): _____

SUPPLEMENTAL BOND ACKNOWLEDGEMENT

PROJECT: _____

OWNER: _____

If the bidder submits a Bid Guaranty and Contract Bond (AKA Rollover or Bid/ Performance/ Payment/ Warranty Bond) per O.R.C. Sections 153.54 and 153.571 the following shall be completed, signed, and submitted with the bid:

By submission of the attached bid and these presents, the undersigned bidder and his surety hereby acknowledge that the attached bond shall cover and warrant all work for the correction period per the General Conditions and as supplemented or amended elsewhere in these Contract Documents, which period is one year(s) commencing on the final acceptance of the work by Owner. Any proceeding, legal or equitable, under this Bond may be instituted in any court of competent jurisdiction in the location in which the project or part of the project is located and shall be instituted within one year from the last day of the correction period under the project or within one year after the Surety refuses or fails to perform its obligations under this Bond, whichever first occurs.

BIDDER

SURETY

SIGNATURE: _____	SIGNATURE: _____
NAME: _____	NAME: _____
TITLE: _____	TITLE: _____
DATE: _____	DATE: _____
PHONE NO.: _____	PHONE NO.: _____

*Attach Power of Attorney

If the Bidder submits a Certified or Cashier's check, Irrevocable Letter of Credit and is awarded a contract by the Owner, the following shall be completed, signed, and submitted with the Contract Bond (AKA Performance/Payment/Warranty Bond) per ORC Sections 153.54 and 153.57.

By signature of the attached Contract and these presents the undersigned contractor and his surety acknowledge that the attached Bond shall cover and warrant all work for the correction period per the General Conditions and as supplemented or amended elsewhere in these Contract Documents, which period is one year(s) commencing on the final acceptance of the work by Owner. Any proceeding, legal or equitable, under this Bond may be instituted in any court of competent jurisdiction in the location in which the project or part of the project is located and shall be instituted within one year from the last day of the correction period under the project or within one year after the Surety refuses or fails to perform its obligations under this Bond, whichever first occurs.

BIDDER

SURETY

SIGNATURE: _____	SIGNATURE: _____
NAME: _____	NAME: _____
TITLE: _____	TITLE: _____
DATE: _____	DATE: _____
PHONE NO.: _____	PHONE NO.: _____

*Attach Power of Attorney

BID SECURITY

**CONTRACTOR SHALL STAPLE ONE OF THE FOLLOWING FORMS
OF BID SECURITY TO THE FRONT OF THIS PAGE AND
SUBMIT WITH THE BID.**

CERTIFIED OR CASHIER'S CHECK FOR 10% OF THE AMOUNT BID

OR

IRREVOCABLE LETTER OF CREDIT FOR 10% OF THE AMOUNT BID

OR

**BOND (BID/PERFORMANCE/PAYMENT" BOND, a.k.a., "ROLLOVER BOND") FOR
100% OF THE AMOUNT BID PER ORC SECTIONS 153.54 AND 153.571**

STATEMENT OF BIDDER QUALIFICATIONS

BIDDER NAME (print/type): _____

BIDDER ADDRESS: _____

BIDDER CONTACT: _____

BIDDER PHONE NUMBER: _____

BIDDER FAX NUMBER: _____

BIDDER E-MAIL: _____

Federal Tax Identification Number: _____

State Tax Identification Number: _____

STATEMENT OF BIDDER QUALIFICATIONS

1. Years in business providing the goods or service requested in this bid. _____
 2. Please list on a separate sheet(s), contracts with municipalities previous and presently held. Please list by community name, contact person, address, phone number, and scope of project (starting with the most recent).
 3. Is your company in satisfactory financial condition? Yes _____ No _____
 4. How many miles is your facility from the Mentor Municipal Center? _____
 5. Please list on a separate sheet(s) the equipment to be used in fulfilling this contract.
 6. Identify the project manager who will be assigned to this project and applicable years of experience managing comparable jobs.
-

For the following questions, on a separate sheet please describe in full the circumstances for any "Yes" answer.

7. Has your company had any business interruptions as a result of financial conditions in the past two (2) years? Yes _____ No _____
8. Has your company been rejected for a public contract despite being a low bidder for any reason? Yes _____ No _____
9. Has your company had any claims against or a performance bond cancelled? Yes _____ No _____
10. Has your company paid penalties or liquidated damages imposed as a result of delay on a public project? Yes _____ No _____
11. Has your company been found to have committed an unfair labor practice or any other employment/labor law violation in such areas as discrimination, prevailing wage, Workers Compensation or OSHA? Yes _____ No _____
12. Has your company in the last three (3) years had a municipal contract cancelled or terminated? Yes _____ No _____

PROPOSAL TO THE CITY OF MENTOR
For Hopkins Road Resurfacing (Asphalt Pavement Planing, Resurfacing)

REF. NO.	DESCRIPTION	QTY.	MEASURE UNITS	UNIT PRICE LABOR	UNIT PRICE MATERIAL	TOTAL UNIT PRICE	ITEM TOTAL
1	(253) PAVEMENT REPAIR, AS PER PLAN	2,500.00	SQ YD	\$	\$	\$	\$
2	(254) PAVEMENT PLANING, BITUMINOUS, AS PER PLAN	34,200.00	SQ YD	\$	\$	\$	\$
3	(407) TACK COAT, 702.13	3,420.00	GALLON	\$	\$	\$	\$
4	(407) TACK COAT, TRACKLESS, FOR INTERMEDIATE COURSE	1,710.10	GALLON	\$	\$	\$	\$
5	(441) ASPHALT CONCRETE INTERMEDIATE COURSE, TYPE 1, (448), PG64-22 (1 1/4")	1,125.24	CU YD	\$	\$	\$	\$
6	(441) ASPHALT CONCRETE SURFACE COURSE, TYPE 1, (448), PG70-22M (1 1/2")	1,350.16	CU YD	\$	\$	\$	\$
7	(608) 4" CONCRETE WALK	500.00	SQ YD	\$	\$	\$	\$
8	(608) CURB RAMP, AS PER PLAN	13.00	EACH	\$	\$	\$	\$
9	(611) MANHOLE/INLET BASIN ADJUSTED TO GRADE	30.00	EACH	\$	\$	\$	\$
10	(611) MONUMENT BOX ADJUSTED TO GRADE, AS PER PLAN	9.00	EACH	\$	\$	\$	\$
11	(614) LAW ENFORCEMENT OFFICER WITH PATROL CAR, AS PER PLAN	100.00	HOUR	XXXXXXXXXX	XXXXXXXXXX	\$60.00	\$6,000.00
12	(614) PORTABLE CHANGEABLE MESSAGE SIGN	4.00	MONTH	\$	\$	\$	\$
13	(614) MAINTAINING TRAFFIC	1.00	LUMP	\$	\$	\$	\$
14	(614) WORK ZONE CENTER LINE, CLASS 1	1.83	MILE	\$	\$	\$	\$
15	(614) WORK ZONE CHANNELIZING LINE, CLASS 1	1,447.00	L.F.	\$	\$	\$	\$
16	(632) DETECTOR LOOP, POWER HEAD, 6' X 30'	14.00	EACH	\$	\$	\$	\$
17	(642) CENTER LINE	1.83	MILE	\$	\$	\$	\$
18	(642) EDGE LINE	2.88	MILE	\$	\$	\$	\$
19	(642) EDGE LINE, 6"	2.99	MILE	\$	\$	\$	\$
20	(642) SCHOOL SYMBOL MARKING 96"	1.00	EACH	\$	\$	\$	\$
21	(642) RAILROAD MARKING MARKING 96"	4.00	EACH	\$	\$	\$	\$
22	(642) CHANNELIZING LINE	1,447.00	L.F.	\$	\$	\$	\$
23	(642) STOP LINE	340.00	L.F.	\$	\$	\$	\$
24	(642) CROSSWALK LINE	684.00	L.F.	\$	\$	\$	\$
25	(642) TRANSVERSE LINE	833.00	L.F.	\$	\$	\$	\$
26	(642) LANE ARROW	14.00	EACH	\$	\$	\$	\$
27	(642) BIKE LANE MARKING	44.00	EACH	\$	\$	\$	\$
28	(642) WORD "ONLY" ON PAVEMENT	12.00	EACH	\$	\$	\$	\$
29	(642) ISLAND MARKING	52.00	SF	\$	\$	\$	\$
30	(SPC) BONDS AND INSURANCES, AS PER PLAN	1.00	LUMP	\$	\$	\$	\$
31	(SPC) PRE-CONSTRUCTION VIDEO, AS PER PLAN	1.00	LUMP	\$	\$	\$	\$
32	(624) MOBILIZATION	1.00	LUMP	\$	\$	\$	\$
33	(442) ASPHALT CONCRETE INTERMEDIATE COURSE, 12.5mm, TYPE A, (448), PG70-22M (1 1/4")	72.84	CU YD	\$	\$	\$	\$
34	(442) ASPHALT CONCRETE SURFACE COURSE, 12.5mm, TYPE A, (448), PG70-22M (1 1/4")	72.84	CU YD	\$	\$	\$	\$
35	CONTINGENCY	1.00	LUMP	XXXXXXXXXX	XXXXXXXXXX	\$70,000.00	\$70,000.00
INFORMAL TOTAL BID \$							

Buy America Certification

PID: 111567 Project Name: LAK-Hopkins Rd Rehabilitation

Project Description: Asphalt overlay of Hopkins Rd from US 20 to Market Street

The undersigned Proposer hereby certifies on behalf of itself and all contractors (at all tiers) that it will meet Buy America requirements in 23 CFR 635.410, using one of the following provisions:

 The product contains no steel or iron products manufactured outside the United States. To be considered domestic, all steel and iron used and all products manufactured from steel and iron must be produced in the United States and all manufacturing processes, including application of a coating, for these materials must occur in the United States. Coating includes all processes that protect or enhance the value of the material to which the coating is applied. The Buy America process does not apply to this project. If there is ANY foreign steel or iron in your product you may not check this box.

 The product has minimal use of steel or iron products manufactured outside the United States. The Buy America regulation does “not prevent a minimal use of foreign steel and iron materials, if the cost of such materials used does not exceed one-tenth of one percent (0.1 percent) of the total contract cost or \$2,500, whichever is greater. For purposes of this paragraph, the cost is that shown to be the value of the steel and iron products as they are delivered to the project. If this minimal use clause applies to your project, then please provide documentation indicating that this requirement is being met. The Buy America process does not apply to your project.

 The product meets the standards for the FHWA Manufactured Products waiver. FHWA policy provides for a Buy America waiver for certain manufactured products. To be eligible for the Manufactured Products waiver, the product must consist of less than 90% steel or iron content when it is delivered to the job site for installation. Please [click here](#) for the full guidance on manufactured products. If your product meets this manufactured products definition, please provide documentation of how the product is a manufactured product and submit to ODOT for approval.

 The product has foreign steel or iron; a Buy America waiver is required. ODOT may, but is not obligated to, seek a waiver of Buy America requirements if grounds for the waiver exist. However, Proposer certifies that it will comply with the applicable Buy America requirements if a waiver of those requirements is not available or not pursued by the Department. The waiver process can take time and the project may not move forward until a waiver is completed.

A false certification is a criminal act in violation of 18 USC 1001. Should this Agreement be investigated, Proposer has the burden of proof to establish that it is in compliance.

Proposer: _____

Signature of Authorized Official: _____

Name of Authorized Official: _____

Title: _____

Date: _____

SECTION 2
CONTRACT FORMS

NOTICE OF AWARD

TO: Contractor

PROJECT: LAK - HOPKINS ROAD REHABILITATION

You are notified that your Bid which was opened on 8/28/20 has been accepted for items in the amount of \$0.00 at the unit bid prices as reflected in the bid tabulation contained herein for Base Bid and Alternates.

You are required by the Instructions to Bidders to execute the Agreement and furnish the required Bonds, Certificates of Insurance, and other documents within 10 calendar days from the date of receipt of this Notice.

Failure to comply with these conditions within the time specified will entitle Owner to consider your Bid in default, to annul this Notice and to declare your Bid Security forfeited.

The Owner will return to you one (1) fully signed set of the contract documents.

CITY OF MENTOR

Kenneth J. Filipiak, City Manager

Date

ACKNOWLEDGMENT

CONTRACTOR

Contractor, President

Date

CONTRACT

FOR LAK-HOPKINS ROAD REHABILITATION

THIS AGREEMENT, made and entered into at Mentor, Ohio, this _____ day of _____, 2020, by and between the City of Mentor (“OWNER”), Ohio and Contractor (“CONTRACTOR”).

WITNESSETH: That the said CONTRACTOR has agreed and by this presents does agree with the OWNER for the consideration hereinafter mentioned and contained, and under penalty expressed in a bond given with these presents, and herein contained or hereunto annexed, to furnish at its own cost and expense, all the necessary tools, equipment, materials, labor, and tests in an expeditious, substantial and workmanlike manner, the equipment and appurtenances herein contemplated, commencing work within 20 days from the date of the Notice to Proceed and executing the work within the time and in the manner specified and in conformity with the requirements set forth in this Contract.

The following form essential parts of the Contract (may vary with project).

1. Advertisement for Bids/Public Notice to Bidders
2. Instruction to Bidders
3. Bid Forms and Proposal
4. Contract Forms and Exhibits
5. Contract Bond – ORC 153.571 or ORC 153.57
6. Contract Provisions
7. General Conditions
8. Supplementary Conditions
9. Specifications
10. Specific Project Requirements
11. Prevailing Wage Rate Schedule
12. Contract Drawings; if any.

The CONTRACTOR agrees and understands that the work on this contract shall be subject to the acceptance of the OWNER based upon and in accordance with the contract specifications and contract plans and drawings on file in the office of the OWNER.

The Contractor agrees that each individual employed by the Contractor or any Subcontractor and engaged in work on the project under this contract shall be paid by prevailing wage established by the Department of Industrial Relations of the State of Ohio or the U.S. Department of Labor (Davis-Bacon Act) as detailed in the section titled "Wage Rates." This shall occur regardless of any contractual relationship which may be said to exist between the Contractor or any Subcontractor and such individual.

The CONTRACTOR shall proceed with the said work in a prompt and diligent manner and shall do the several parts thereof. Further he shall complete the whole of said work in accordance with the specifications and contract drawings to the satisfaction of the OWNER on or before the time stated, and in default of completion within the time as fixed, the CONTRACTOR shall pay to the OWNER as liquidated damages, an amount equal to \$500.00 Per Day, for each and every day (Sundays and legal holidays excepted) the completion of the work may be delayed beyond the date fixed in the manner and as stipulated.

It is hereby mutually agreed that the OWNER is to pay and the CONTRACTOR is to receive, as full compensation for furnishing all materials and labor in building, constructing and testing and in all respect completing the herein described work and appurtenances in the manner and under the conditions herein specified, the prices stipulated in the proposal herein contained or hereto annexed and the total contract sum is \$0.00.

This Contract shall be in full force and effect from the date of execution by the parties.

IN WITNESS WHEREOF: The parties hereunto affixed their signature the day and year first mentioned above.

CONTRACTOR

Contractor, President

CITY OF MENTOR

Kenneth J. Filipiak, City Manager

I hereby certify that funds in the amount of 00/100 Dollars (\$0.00) necessary for the foregoing Contract have been appropriated and are in the Treasury, or are in the process of collection, or are available through grants and/or loans from other funding sources.

David W. Malinowski, Finance Director

APPROVED AS TO FORM:

Joseph P. Szeman, Law Director

**THE CONTRACTOR SHALL FURNISH THE FOLLOWING ITEMS
WITHIN 10 DAYS OF NOTIFICATION OF AWARD:**

- A) **CERTIFICATE OF INSURANCE FOR
CONTRACTOR'S PUBLIC LIABILITY INSURANCE POLICY
AND AUTOMOTIVE INSURANCE POLICE**

 - B) **CERTIFICATE OF INSURANCE FOR
OWNER'S AND CONTRACTOR'S PROTECTIVE POLICY**

 - C) **CERTIFICATE OF WORKER'S COMPENSATION**

 - D) **CONTRACT BOND THAT COMPLIES WITH ORC 153.54 AND 153.57**
Submitted bond complying with ORC 153.54 and 153.571 (rollover bond) with Bid
- * D above is not required if a bond complying with ORC 153.54 and 153.571 (rollover bond) was submitted at time of bid.
- E) **DRUG-FREE SAFETY OR COMPARABLE PROGRAM**

 - E) **EEO CERTIFICATE OF COMPLIANCE**

DELINQUENT PERSONAL PROPERTY STATEMENT

Contractor, having been awarded a contract by the City of Mentor, Ohio, hereby affirms under oath, pursuant to Ohio Revised Code Section 5719.042, that at the time the bid was submitted, my company **was / was not (CIRCLE ONE)** charged with delinquent personal property taxes on the General Tax List of Personal Property for Lake County, Ohio.

If such charge for delinquent personal property tax exists on the General Tax List of Personal Property for Lake County, Ohio, the amount of such due and unpaid delinquent taxes, including due and unpaid penalties and interest shall be set forth below.

A copy of this statement shall be transmitted by the Taxing District's Fiscal Officer to the County Treasurer within thirty days of the date it is submitted. A copy of this statement shall also be incorporated into the Contract made between City of Mentor, Ohio, and CONTRACTOR, and no payment shall be made with respect to any Contract unless such statement has been so incorporated as a part thereof.

Delinquent Personal Property Tax	\$ _____
Penalties	\$ _____
Interest	\$ _____

CONTRACTOR

Contractor, President

AFFIDAVIT
OF COMPLIANCE WITH OHIO REVISED CODE SECTION 3517.13

STATE OF OHIO

COUNTY OF _____

_____ being duly sworn deposes and states as follows:

1. I am duly authorized to make the statements contained herein on behalf of _____ (“the Contracting Party”).
2. The Contracting Party is a/an (select one):
 - Individual, partnership, or other unincorporated business association (including without limitation, a professional association organized under Ohio Revised Code Chapter 1787), estate, or trust
 - Corporation organized and existing under the laws of the State of _____
 - Labor organization
3. I hereby affirm that the Contracting Party and each of the individuals specified in R.C. 3517.13(I) (with respect to non-corporate entities and labor organizations) or R.C. 3517.13(J) (with respect to corporations) are in full compliance with the political contribution limitations set forth in R.C. 3517.13(I) and (J), as applicable.
4. I understand that a false representation on this certification will incur penalties pursuant to 3517.992(R)(3).

Affiant further sayeth naught.

By: _____

Title: _____

SWORN TO BEFORE ME and subscribed in my presence this _____ day of _____, 2020.

Notary Public

My commission expires: _____

ESCROW WAIVER

In accordance with a certain Contract between the «OwnerMuni», «OwnerState», (hereinafter referred to as "the Owner") and «ContractName», (hereinafter referred to as "the Contractor") it is mutually agreed by and between the parties hereto that because of the short-term duration of the within contract, no escrow account will be established pursuant to Sections 153.13, 153.14 and 153.63 of the Ohio Revised Code nor shall any interest be paid on any retainage.

CONTRACTOR

Contractor, President

CITY OF MENTOR

Kenneth J. Filipiak, City Manager

NOTICE TO PROCEED

Project: LAK - Hopkins Road Rehabilitation

Owner: City of Mentor
8500 Civic Center Boulevard
Mentor, Ohio 44060

To: Contractor

Date: _____

You are hereby notified to commence work in accordance with the Contract. All work shall be completed by June 18, 2021.

CITY OF MENTOR

Kenneth J. Filipiak, City Manager

REV. 3/2020

**CONTRACTOR SHALL COMPLETE THE FOLLOWING AND RETURN
WITHIN 10 DAYS OF NOTICE OF AWARD:**

- A) AFFIDAVIT OF COMPLIANCE WITH POLITICAL CONTRIBUTIONS
LIMITATION (ORC 3517.13)**

**THE OWNER OR THEIR AUTHORIZED REPRESENTATIVE SHALL INSERT
THE FOLLOWING CONTRACT DOCUMENTATION IN THE EXECUTED
CONTRACT:**

- A) FINDINGS FOR RECOVERY – ORC 9.24**

- B) NOTIFICATION OF SURETY AND AGENT OF CONSTRUCTION
CONTRACT AWARD – ORC 9.32 (if applicable)**

- C) NOTIFICATION TO UTILITY COMPANIES OF COMMENCEMENT OF
CONTRACT EXECUTION – ORC 153.64 (if applicable)**

NOTE: This section has been removed from the plans. Refer to ODOT CMS Section 100 as modified by the City of Mentor Engineer's Office.

SECTION 4
SUPPLEMENTARY CONDITIONS

SUPPLEMENTARY CONDITIONS

These Supplementary Conditions supplement Section 100 of the ODOT CMS and other provisions of the Contract Documents as indicated below. All provisions which are not so amended or supplemented remain in full force and effect.

Any reference to ODOT shall also apply to the City of Mentor. All references to Owner shall mean the City of Mentor.

Change the number of copies of the Contract Documents to be furnished to the Contractor to “two executed copies and up to four non-executed bid set copies.”

The Contractor shall furnish a Certificate of Insurance satisfactory to the Owner from each Insurance Company showing that all required insurance is in force, stating policy numbers, dates of expiration, and limits of liability thereunder. If the Contractor fails to procure and maintain the said insurance, the Owner shall have the right to procure and maintain the said insurance for and in the name of the Contractor and the Contractor shall pay the cost thereof and shall furnish all necessary information to make effective and maintain such insurance.

The limits of liability for the insurance required by Section 107.12 of the CMS shall be amended to provide coverage for not less than the following amounts or greater where required by Laws and Regulations.

Workers’ Compensation:

- | | | |
|-----|----------------------|-------------|
| (a) | State | Statutory |
| (b) | Applicable Federal | Statutory |
| (c) | Employer’s Liability | \$1,000,000 |

Contractor’s Liability Insurance shall also include completed operations and product liability coverage.

- | | | |
|-----|--|--------------|
| (a) | Bodily Injury and Property Damage, Combined Single Limit (CSL) (Except Products and Completed Operations) Property Damage liability insurance will provide Explosion, Collapse, and Underground coverage where applicable. | |
| | Each Occurrence | \$2,000,000* |
| | General Aggregate | \$4,000,000* |
| (b) | Products and Completed Operations Aggregate | \$1,000,000 |

Products and Completed Operations to be maintained for two (2) years after final payment and Contractor shall continue to provide evidence of such coverage to the Owner on an annual basis during the aforementioned period.

- (c) Personal and Advertising Injury (Per Person/Organization and per occurrence) with Employment Exclusion deleted. \$1,000,000
- (d) Fire Damage \$100,000
- (e) *Umbrella Excess Liability – As needed to increase primary policy to limits.
- (f) If the General Liability Policy includes a General Aggregate, such policy shall be endorsed to have General Aggregate apply to this project only (Per Project Aggregate Limit).

Automobile Liability – (Owned, Non-Owned, Hired) Contractor may provide split limits or combined single limit.

- (a) Split Limits:

Bodily Injury,	Each Person:	\$2,000,000
	Each Occurrence:	\$2,000,000
Property Damage,	Each Occurrence:	\$1,000,000

or

- (b) Combined Single Limit

Bodily Injury and Property Damage	Each Occurrence	\$2,000,000
-----------------------------------	-----------------	-------------

- (c) Umbrella Excess Liability – as needed to increase Primary Policy to specified limits.

The Contractor shall purchase and provide an “Owner’s and Contractor’s Protective Policy” for the following limits (ODOT shall be named in addition to the City of Mentor):

Each Occurrence	\$1,000,000
General Aggregate	\$2,000,000

The Contractor shall purchase and maintain during the Contract Time “All Risk Builders’ Risk Insurance,” and/or “Installation Floater Insurance,” and/or “Boiler and Machinery Insurance,” and any and all insurance requirements as applicable for the type of work to be performed upon the Project to the full insurable value thereof for the benefit of the Owner, the State, the Contractor, Subcontractors and Suppliers as their interest may appear. This insurance shall cover the work until final acceptance and final payment by the Owner. This provision shall in no way release the Contractor or Contractor’s Surety from obligations under the Contract Documents to fully complete the Project. The original policy(s) shall be filed with the Owner or his designated representative.

Owner is exempt from Ohio State Sales and Use Taxes on materials and equipment to be incorporated in the Project. Said taxes shall not be included in the Contract Price.

Until the job is 50% complete, the Contractor will be paid 92% of the estimated value of labor and material completed in acceptable form. After the work is 50% complete, no further funds shall be retained and the Contractor shall be paid 100% of the estimated value of labor and material completed in acceptable form, provided that the Contractor is making satisfactory progress and there is no specific cause for greater withholding. Upon the Owner's agreement that the project is substantially complete, the Retainage may be reduced to twice the value of the remaining punch list work subject to the recommendation of the Engineer and the approval of the Owner.

Payment for stored materials at invoice prices or at the unit price bid for materials, or the lesser value of the two, will be made for accepted nonperishable equipment and materials which are to be incorporated into the work, when accepted, delivered, properly stored, and protected upon the site and verified to the Engineer by a copy of the invoice. For materials and equipment meeting the foregoing conditions, the Owner will pay, when properly included in an approved estimate, 92% of the invoice value of the same. Subsequent to the inclusion of a payment for delivered materials in a progress payment, Contractor shall submit no later than the next payment submission, a partial waiver of lien from each and every supplier for whom delivered materials were paid. If no such waiver is submitted prior to or along with the next payment, the amount of delivered materials paid commensurate with that particular item will be deducted from future payments. No payment for delivered materials shall be made for any items that are scheduled to be incorporated in the work within 30 days of submission of the pay estimate. Delivered materials will not be paid in any given month for a total amount less than \$5,000.00. Payment for delivered materials for such items as roadway subbase and pipe backfill will not be routinely considered.

Dispute Resolution shall be as per the attached Exhibit A – "Dispute Resolution Agreement."

EXHIBIT A

DISPUTE RESOLUTION AGREEMENT – JUDICIAL SYSTEM

OWNER and CONTRACTOR hereby agree that:

All claims submitted by the contractor must be submitted to the Project Manager for review and shall include all supporting documentation for the claim. The Project Manager will review each claim and will make a recommendation to the City regarding resolution of the claim. The Project Manager will then submit the results of the review to the Contractor. If no satisfactory resolution has occurred, the contractor may request a meeting with the City engineering staff to present their reasoning and any additional documentation to support their claim. The City's engineering staff will then determine the outcome of the claim.

If no resolution can be attained then the following shall apply:

All claims, disputes and other matters in question between Owner and Contractor arising out of or relating to the Contract Documents or the breach thereof (except for claims which have been waived by the making or acceptance of final payment) will be decided through the Lake County Court of Common Pleas. Arbitration will be entered into only if agreed upon in writing by both parties.

SECTION 5
SPECIFICATIONS

SECTION 01010 - SUMMARY OF WORK

PART 1 - GENERAL

1.1 LOCATION OF THE PROJECT

- A. The project is located in the City of Mentor along Hopkins Road from Market Street to US 20 (Mentor Avenue).

1.2 PROJECT DESCRIPTION

- A. The project consists of resurfacing the full width of Hopkins Road between Market Street and US 20(Mentor Avenue) with asphalt and includes sections of full depth pavement repair, as directed by the Engineer. Storm inlet, manhole and monument box adjustment, related traffic signal repairs and ADA curb ramp reconstruction (as necessary) will also be completed as part of the improvements.

1.3 SPECIFICATIONS

- A. In general, these Specifications describe the work to be performed by the various trades, other than work specifically excluded. It shall be the responsibility of Contractors and Subcontractors to perform all work incidental to their trade, whether or not specific mention is made of each item, unless such incidentals are included under another Item.
- B. It is advised that all Contractors and Subcontractors familiarize themselves with the contents of the complete Specifications, particularly for the trades preceding, following, related or adjacent to their work.

1.4 DRAWING SCHEDULE

- A. The work to be done under these Contracts is shown on the attached quantity summary sheets and/or the drawings in Section 9 and the appendix.

END OF SECTION 01010 (1/15/20)

SECTION 01020 - GENERAL REGULATIONS AND PERMITS

PART 1 - GENERAL

1.1 REGISTRATION

The Prime Contractor(s) shall be registered with the Owner's Building Department. Registration shall include completing required forms, providing a certificate of liability insurance, and a One Hundred dollar (\$100.00) registration fee.

If the Contractor performs any work within the municipal limits outside the performance of this contract, he shall provide a separate Ten Thousand Dollar (\$10,000.00) registration bond.

If the contractor performs work only within this contract, he may submit the Contract Performance Bond in lieu of a Ten Thousand Dollar (\$10,000.00) registration bond.

1.2 PERMITS

The General Contractor shall apply for all building or right of way permits from the Owner or other authorities. Permit and inspection fees payable to the Owner will be waived unless otherwise stated in the specifications. All permit and inspection fees required by other authorities shall be paid for by the General Contractor.

SECTION 01038 - SAMPLING AND TESTING

PART 1 - GENERAL

1.1 QUALITY CONTROL

- A. The Contractor shall be responsible for the quality of all materials incorporated into the project work and shall be responsible for all costs of testing and certification of same.
- B. The Contractor shall provide the Engineer with a Quality Control Plan in which his testing methods/procedures are defined. Said Plan shall meet with the approval of the Engineer and include identification of laboratories, types of testing, and the tentative amount and scheduling of each.

All certifications of tests and/or gradations for materials to be utilized in the work and all quality control testing shall be performed by an independent laboratory (not affiliated with, owned by, or managed by the Contractor). The laboratory shall be accredited by the AASHTO Materials Reference Laboratory for the type of testing performed.

- C. The Owner may perform field Quality Assurance testing; however, such testing shall not relieve the Contractor from the responsibility of Quality Control testing or from supplying certificates from manufacturers or suppliers to demonstrate compliance with the specifications. It is intended that the testing by the Contractor and the Owner be complimentary toward a quality project; however, the Contractor may not assume the Owner will test or that any tests will be done in lieu of the Contractor's own Quality Control testing. In the same sense, the Contractor may not rely on Owner Quality Assurance testing as a basis of acceptance or approval of his work nor may any Owner performed testing be reflected in his submitted plan.

1.2 TEST CRITERIA

- A. The following tests at a minimum shall be included with the Contractor's Quality Control Plan in accordance with the specifications:
 - 1. Aggregates
 - a. For each material and/or different source, the laboratory shall perform soundness, gradation, and other tests for all parameters specified. Aggregates incorporated into concrete or asphalt mixes shall also be tested for moisture content daily.
 - 2. Compaction Tests
 - a. Compaction tests or field density tests shall be taken on all embankment, trench backfill, subgrade, and subbase materials.

- b. Minimum testing shall be as follows:
 - Embankment testing shall be at least one (1) test/5000 S.F. of each lift;
 - Trench backfill testing shall be at least one (1) test/50 L.F. of each lift;
 - Subgrade and/or subbase testing shall be at least one (1) test/200 L.F. of pavement or /5000 S.F. of slabs; subject to greater frequency due to soil conditions or Engineer's direction.
 - c. Proctors or relative density tests shall be performed as often as necessary for the differing soils or granular materials utilized. Proctors shall be run with a minimum of 5 points. Test reports shall show the wet (bulk) weight, dry weight, wet (bulk) density, dry density, moisture content weight and moisture content percentage. Both the dry curve and the wet curve shall be plotted.
3. Concrete Mix Design
- a. For each type of concrete, the laboratory shall perform the necessary mix design providing all test data as required by the specifications.
4. Concrete Field and Laboratory Tests
- a. The laboratory shall cast concrete cylinders and test beams:
 - 1) One set of four cylinders per 50 C.Y. with a minimum of two sets per day. The cylinders shall be broken: one at 7 days, two at 28 days, one at 56 days, unless otherwise directed by the Engineer.
 - 2) One beam per 50 C.Y. with a minimum of two beams per day.
 - b. Temperature and unit weight shall be run on fresh concrete at intervals sufficient for the type of structure being placed and a minimum of once per day. Bulk weight, bucket weight, (tare), net weight, bucket factor (bucket volume) and unit weight shall be recorded on the fresh concrete report. Show all batch weights for yield calculations. Slump and air content tests shall be taken a minimum of one test per 20 C.Y. and at least once per day.
 - c. All field and laboratory testing shall be performed by technicians certified by the American Concrete Institute (ACI) for the type of testing performed.
 - d. Initial cure of all cylinders shall be in a temperature controlled cure box or temperature controlled water tank with a hi-low thermometer. Hi-low temperature readings shall be recorded on the fresh concrete report.
5. Asphalt Mix Design
- a. For each type of asphalt mix, submit job mix formula (JMF) prepared by an ODOT pre-qualified laboratory from tests performed on the aggregates proposed for use.
 - b. Sample and test for gradation and bitumen content as per ODOT 441.

1.3 LABORATORY REPORTS

- A. Reports of laboratory and field tests will be distributed to the Engineer, Owner, and Suppliers within 24 hours of completion.

END OF SECTION 01038 (7/2008)

SECTION 01041 - PRE-CONSTRUCTION VIDEO DOCUMENTATION

PART 1 - GENERAL

1.1 SCOPE

- A. Provide all labor, materials, equipment, and services, and perform all operations necessary to furnish to the Owner a complete color audio-video flash drive record of the surface features within the proposed construction zone of influence. This record shall include, but not be limited to, all audio-video DVDs, storage cases, video logs, and indexes. The purpose of this coverage shall be to accurately document the pre-construction condition of these surface features.

1.2 QUALIFICATIONS

- A. The video documentation shall be done by a responsible commercial firm known to be skilled and regularly engaged in the business of pre-construction color audio-video documentation. The firm shall furnish such information as the owner deems necessary to determine the ability of that firm to perform the work in accordance with the Contract specifications.

1.3 PRODUCTS

- A. The color audio-video recording delivered to the Owner shall be on a flash drive format.

END OF SECTION 01041

SECTION 01051 - ADDITIONAL WORK, OVERTIME

PART 1 - GENERAL

1.1 NIGHT, SUNDAY AND HOLIDAY WORK

- A. No work will be permitted at night, Sunday or legal holidays except as noted on the plans or in the case of emergency and then only upon written authorization of the Engineer. Where no emergency exists, but the Contractor feels it advantageous to work at night, Sunday or legal holidays, the Contractor shall notify the Engineer at least two (2) days in advance, requesting written permission. Any work performed during the absence of the Engineer will be done at the Contractor's risk and responsibility and may be subject to rejection upon later inspection.

END OF SECTION 01051 (10/93)

SECTION 01061 - SHOP DRAWINGS AND SUBMITTALS

PART 1 - GENERAL

1.1 GENERAL

- A. The Contractor shall submit detailed drawings, acceptable catalog data, specifications and material certifications for all equipment and materials specified or required for the proper completion of the work.
- B. The intent of these items is to demonstrate compliance with the design concept of the work and to provide the detailed information necessary for the fabrication, assembly and installation of the work specified. It is not intended that every detail of all parts of manufactured equipment be submitted, however sufficient detail will be required to ascertain compliance with the specifications and establish the quality of the equipment proposed.

Shop Drawings shall be sufficiently clear and complete to enable the Engineer/Architect and Owner to determine that items proposed to be furnished conform to the specifications and that items delivered to the site are actually those that have been reviewed.

- C. It is emphasized that the Engineer/Architect's review of Contractor's submitted data is for general conformance to the contract drawings and specifications but subject to the detailed requirements of drawings and specifications. Although the Engineer/Architect may review submitted data in detail, such review is an effort to discover errors and omissions in Contractor's drawings. The Engineer/Architect's review shall in no way relieve the Contractor of his obligation to properly coordinate the work and to Engineer/Architect the details of the work in such manner that the purposes and intent of the contract will be achieved. Such review by the Engineer/Architect shall not be construed as placing on him or on the Owner any responsibility for the accuracy and for proper fit, functioning or performance of any phase of the work included in the contract.
- D. Shop Drawings shall be submitted in proper sequence and with due regard to the time required for checking, transmittal and review so as to cause no delay in the work. The Contractor's failure to transmit appropriate submittals to the Engineer/Architect sufficiently in advance of the work shall not be grounds for time extension.
- E. The Contractor shall submit Shop Drawings for all fabricated work and for all manufactured items required to be furnished in the Contract in accordance with the General Provisions and as specified herein. Shop Drawings shall be submitted in sufficient time to allow at least twenty-one (21) calendar days after receipt of the Shop Drawings from the Contractor for checking and processing by the Engineer/Architect.
- F. It is the responsibility of each Prime Contractor to furnish to all other Prime Contractors and especially the General Construction Contractor reviewed Shop Drawings for guidance in interfacing the various trades; i.e., sleeves, inserts, anchor bolts, terminations, and space requirements.

- G. No work shall be performed requiring Shop Drawings until same have been reviewed by Engineer/Architect.
- H. Accepted and reviewed Shop Drawings shall not be construed as approval of changes from Contract plan and specification requirements.
- I. The Engineer/Architect will review the first and second Shop Drawing item submittals at no cost to the Contractor. Review of the third submittal and any subsequent submittal will be at the Contractor's expense. Payment will be deducted from the Contract amount at a rate of 2.8 times direct labor cost plus expenses.

1.2 SUBMITTAL PROCEDURE

- A. All required submissions shall be made to the Engineer/Architect by the Prime Contractor(s) only. Any data prepared by subcontractors and suppliers and all correspondence originating with subcontractors, suppliers, etc., shall be submitted through the Contractor.
- B. Contractor shall review and approve all Shop Drawings prior to submission. Contractor's approval shall constitute a representation to Owner and Engineer/Architect that Contractor has either determined and verified all quantities, dimensions, field construction criteria, materials, catalog numbers, and similar data or assumes full responsibility for doing so, and that Contractor has reviewed or coordinated each Shop Drawing or sample with the requirements of the work and the Contract Documents.
- C. Submittal Preparation: Mark each submittal with a permanent label or page for identification. Provide the following information on the label for proper processing and recording of action taken:
 - 1. Location
 - 2. Project Name
 - 3. Contract
 - 4. Name and Address of Engineer/Architect
 - 5. Name and Address of Contractor
 - 6. Name and Address of Subcontractor
 - 7. Name and Address of Supplier
 - 8. Name of Manufacturer
 - 9. Number and Title of appropriate Specification Section
 - 10. Drawing Number and Detail References, as appropriate.
 - 11. Submittal Sequence or Log Reference Number.
 - a. Provide a space on the label for the Contractor's review and approval markings and a space for the Engineer/Architect's "Action Stamp".
- D. Each Shop Drawing, sample and product data submitted by the Contractor shall have affixed to it the following Certification Statement including the Contractor's Company name and signed by the Contractor:

Certification Statement: By this submittal, I hereby represent that I have determined and verified all field measurements, field construction criteria, materials, dimensions, catalog numbers and similar data and I have checked and coordinated each item with other applicable approved shop drawings and all Contract requirements.

Signature

Date

Company

- E. Shop Drawings shall be submitted in not less than six (6) copies to the Engineer/Architect at the address specified at the Preconstruction Conference. Single mylar or sepia reproducible copies of simple Shop Drawings may be submitted with prior approval of the Engineer/Architect.
- F. At the time of each submission, Contractor shall in writing identify any deviations that the Shop Drawings or samples may have from the requirements of the Contract Documents.
- G. Drawings shall be clean, legible and shall show necessary working dimensions, arrangement, material finish, erection data, and like information needed to define what is to be furnished and to establish its suitability for the intended use. Specifications may be required for equipment or materials to establish any characteristics of performance where such are pertinent. Suitable catalog data sheets showing all options and marked with complete model numbers may, in certain instances, be sufficient to define the articles which it is proposed to furnish.

1.3 REVIEW PROCEDURE

- A. Engineer/Architect will review within two weeks all properly submitted Shop Drawings. Such review shall be only for conformance with the design concept of the Project and for compliance with the information given in the plans and specifications and shall not extend to means, methods, sequences, techniques or procedures of construction or to safety precautions or programs incident thereto.
- B. The review of a separate item as such will not constitute the review of the assembly in which the item functions. The Contractor shall submit entire systems as a package.
- C. All Shop Drawings submitted for review shall be stamped with the Engineer/Architect's action and associated comments.
- D. Except for submittals for record, information or similar purposes, where action and return is required or requested, the Engineer/Architect will review each submittal, mark to indicate action taken, and return accordingly. Compliance with specified characteristics is the Contractor's responsibility.

Action Stamp: The Engineer/Architect will stamp each submittal with a uniform, self-explanatory action stamp. The stamp will be appropriately marked, as follows, to indicate the action taken:

1. If Shop Drawings are found to be in general compliance, such review will be indicated by marking the first statement.
 2. If only minor notes in reasonable number are needed, the Engineer/Architect will make same on all copies and mark the second statement. Shop Drawings so marked need not be resubmitted.
 3. If the submitted Shop Drawings are incomplete or inadequate, the Engineer/Architect will mark the third statement, request such additional information as required, and explain the reasons for revision. The Contractor shall be responsible for revisions, and/or providing needed information, without undue delay, until such Shop Drawings are acceptable. Shop Drawings marked with No. 3 shall be completed resubmitted.
 4. If the submitted Shop Drawings are not in compliance with the Contract Documents, the Engineer/Architect will mark the fourth statement. The Contractor will be responsible to submit a new offering conforming to specific products specified herein and/or as directed per review citations.
- E. No submittal requiring a Change Order for either value or substitution or both, will be returned until the Change Order is approved or otherwise directed by the Owner.

APPLICATION FOR USE OF SUBSTITUTE ITEM

TO: _____

PROJECT: _____

SPECIFIED ITEM:

Page	Paragraph	Description
------	-----------	-------------

A. The undersigned requests consideration of the following as a substitute item in accordance with Article 6.05 of the General Conditions.

B. Change in Contract Price (indicate + or -) \$ _____

C. Attached data includes product description, specifications, drawings, photographs, references, past problems and remedies, and performance and test data adequate for evaluation of the request; applicable portions of the data are clearly identified. For consideration of the attached data as SHOP DRAWINGS, submittal shall be in accordance with requirements of Section 01300.

D. Attached data also includes a description of changes to the Contract Documents that the proposed substitution will require for its proper installation.

The undersigned certifies that the following paragraphs, unless modified by attachments are correct:

1. The proposed substitute does not affect dimensions shown on Drawings.
2. The undersigned will pay for changes to the building design, including engineering design, detailing, and construction costs caused by the requested substitution.
3. The proposed substitution will have no adverse affect on other contractors, the construction schedule, or specified warranty requirements. (If proposed substitution affects construction schedule, indicate below using + or -)

_____ CONSECUTIVE CALENDAR DAYS

The undersigned further states that the function, appearance, and quality of the proposed substitution are equivalent or superior to the specified item, and agrees to reimburse the OWNER for the charges of the ENGINEER for evaluating this proposed substitute item.

E. Signature:

Firm:

Address:

Telephone: _____ Date: _____

Attachments: _____

For use by ENGINEER:

- _____ Accepted as evidenced by affixed SHOP DRAWING REVIEW stamp.
- _____ Accepted as evidenced by included CHANGE ORDER.
- _____ Not accepted as submitted. See Remarks.
- _____ Acceptance requires completion of submittal as required for SHOP DRAWINGS.
- _____ Not accepted. Do not resubmit.

By: _____ Date: _____

Remarks: _____

APPLICATION FOR USE OF "OR-EQUAL" ITEM

TO: _____

PROJECT: _____

SPECIFIED ITEM:

Page	Paragraph	Description
------	-----------	-------------

A. The undersigned requests consideration of the following as an "or-equal" item in accordance with Article 6.05 of the General Conditions.

B. Change in Contract Price (indicate + or -) \$ _____

C. Attached data includes product description, specifications, drawings, photographs, references, past problems and remedies, and performance and test data adequate for evaluation of the request; applicable portions of the data are clearly identified. For consideration of the attached data as SHOP DRAWINGS, submittal shall be in accordance with requirements of Section 01061.

D. Signature:

Firm: _____

Address: _____

Telephone: _____

Date: _____

Attachments: _____

For use by ENGINEER:

_____ Accepted as evidenced by affixed SHOP DRAWING REVIEW stamp.

_____ Accepted as evidenced by included CHANGE ORDER.

_____ Not accepted as submitted. See Remarks.

_____ Acceptance requires completion of submittal as required for SHOP DRAWINGS.

_____ Not accepted. Do not resubmit.

By: _____ Date: _____

Remarks: _____

END OF SECTION 01061 (01/96)

SECTION 01066 - TEMPORARY WATER AND DISTRIBUTION

PART 1 - GENERAL

1.1 WATER

- A. The Contractor shall be responsible for an adequate supply of water suitable for his use for construction and drinking. At his own expense he shall provide and maintain adequate supplies and supply lines in such locations and installed in such a manner as may be satisfactory to the Engineer

END OF SECTION 01066 (10/93)

SECTION 01080 – FIRST AID

PART 1 - GENERAL

1.1 AID TO THE INJURED

- A. The contractor shall keep on the work site all articles necessary for giving “First Aid to the Injured”. He shall also have standing arrangements for the immediate removal and hospital treatment of any employee or other person who may be injured on the work site.

END OF SECTION 01080 (8/99)

SECTION 01091 - ENVIRONMENTAL PROTECTION

PART 1 - GENERAL

1.1 UNNECESSARY NOISE, DUST AND ODORS

- A. The Contractor's performance of this contract shall be conducted so as to eliminate all unnecessary noise, dust and odors.

1.2 SEWAGE, SURFACE AND FLOOD FLOWS

- A. The Contractor shall take whatever action is necessary to provide all necessary tools, equipment and machinery to adequately handle all sewage, surface and flood flows which may be encountered during the performance of the work. The entire cost of and liability for handling such flows is the responsibility of the Contractor and shall be included in the price for the appropriate item.

1.3 WORK IN FREEZING WEATHER

- A. Written permission from the Engineer shall be obtained before any work is performed which, in the judgment of the Engineer, may be affected by frost, cold, or snow. When work is performed under such conditions, the Contractor shall provide facilities for heating the materials and for protecting the finished work.

1.4 POLLUTION CONTROL

- A. It shall be the responsibility of the Contractor to prevent or limit pollution of air and water resulting from his operations.
- B. The Contractor shall perform work required to prevent soil from eroding or otherwise entering onto all paved areas and into natural watercourses, ditches, and public sewer systems, and to prevent dust attributable to his operations from entering the atmosphere.
- C. Dust on unsurfaced streets or parking areas and any remaining dust on surfaced streets shall be controlled with calcium chloride dust palliative as directed by the Engineer.

1.5 ENVIRONMENTAL COMMITMENTS

- A. All work shall be performed within the existing right of way.
- B. No work shall occur within streams or wetlands.

SECTION 01099 - FINAL COMPLIANCE AND SUBMITTALS

PART 1 - GENERAL

- 1.1 The following forms and related sign-offs shall be documented in accordance with provisions of the contract. These forms shall be completed by the Contractor and approved by the Owner before final retainer is approved for release. Forms for Items A to E will be attached to the Contractor's executed copy of the contract.
- A. Certificate of Substantial Completion (To be submitted at time of Substantial Completion).
 - B. Contractor's Certification of Completion.
 - C. Contractor's Affidavit of Prevailing Wage.
 - D. Consent of Surety Company for Final Payment.
 - E. Affidavit of Final Acceptance Date and Correction Period.
 - F. Certificate of insurance verifying completed operations insurance coverage.

END OF SECTION 01099 4/04

SECTION 02235 - COMPACTED GRANULAR BACKFILL

PART 1 - GENERAL

1.1 RELATED DOCUMENTS

- A. Drawings and general provisions of Contract, including General and Supplementary Conditions and Division-1 Specification sections, apply to work of this section.

1.2 DESCRIPTION OF WORK

- A. The Contractor shall furnish, place and compact all the materials needed.

PART 2 - PRODUCTS

2.1 MATERIAL

- A. Aggregate shall be well graded from coarse to fine and be free of dirt and shall be of an aggregate size conforming to ODOT No. 304 and material type shall be as per ODOT No. 304.
- B. Contractor shall submit current test reports for the lot(s) of the material to be supplied.

PART 3 - EXECUTION

3.1 PLACING AND COMPACTING

- A. Compacted granular backfill shall be properly placed in layers sufficient to meet the compaction requirement of 100% of maximum laboratory dry density per ASTM D 698 throughout the entire layer and thoroughly compacted with mechanical compaction equipment with moisture adjustment as needed. Should after settlement occur, the Contractor must add and compact additional material, and he must maintain the backfill at the required finished grade or sub-grade until the project is satisfactorily completed and during the correction period.
- B. Approved mechanical compaction equipment shall be used for tamping backfill. Flooding, jetting or puddling of backfill will not be permitted.

SECTION 02520 - ASPHALT CONCRETE PAVING AND MATERIALS

SECTION 1 - MATERIALS

- 1.1 The asphalt concrete mixture and installation thereof shall meet Ohio Department of Transportation (ODOT) Specifications except as modified in these specifications.
- 1.2 In the ODOT Specifications substitute "Engineer" for "Department" (except as stated below in reference to ODOT 403 for Department VA testing and acceptance).
- 1.3 No steel slag shall be used as coarse or fine aggregate for any asphalt concrete. The coarse virgin aggregate shall be a blend of 60% min. air cooled blast furnace slag (ACBFS) or Trap Rock from Ontario with limestone comprising the remaining percentage.
- 1.4 All asphalt cement utilized on this project shall meet AASHTO Provisional Standard MP1 or any superseding AASHTO specification for performance graded asphalt cement binder in conformance with PG 64-22 and 70-22M.
- 1.5 Except where designated otherwise in the plans or specifications all asphalt concrete mixes shall be designed for medium traffic volumes. NOTE: all 441 asphalt concrete mixes are automatically designed for medium traffic.
- 1.6 Acceptance of the mixture will be based upon the certification that the mixture was produced according to the approved JMF within the production control and composition tolerances of the specifications. The Contractor shall hire and pay for an independent testing lab approved by the Engineer to perform all sampling, testing, monitoring, analysis and certification required by the Laboratory, Monitoring Team or Department in ODOT 403 and 441. All work by the independent laboratory shall be performed by personnel with ODOT Level II Bituminous Concrete certification.
- 1.7 ODOT 401.20 - "**Asphalt Binder Price Adjustment**" shall not apply to this contract.
- 1.8 Brick used for manhole, catch basin, or inlet basin castings adjusted to grade under Method A shall be red shale or clay sewer brick meeting the requirements of ASTM C32 sewer brick, grade SM.
- 1.9 All materials delivered to this project must have been weighed on a platform scale with electronic imprinter to show gross, tare, and net weights. No payment will be made for materials which are not correctly weighed as necessary. Material weight shall not exceed the current legal allowable limit.
- 1.10 Unless specified elsewhere in the specifications, material for berms shall be limestone only. Recycled concrete and asphalt concrete will not be permitted.

SECTION 2 - PAVING EQUIPMENT

REV. 4/9/15

- 2.1 All spreading equipment shall be self propelled. The Contractor shall identify the make and model of the paving machine that will be used for the intermediate and surface courses for approval prior to the pre-construction meeting.
- 2.2 All equipment, tools, and machines used in the performance of this work shall be maintained in satisfactory working order at all times. The Contractor shall be prepared to furnish proof of certification that all equipment to be used on the project has been calibrated within the past six (6) months.

SECTION 3 - GENERAL - PAVING

- 3.1 All paving shall be done on a single-lane basis. Tandem or echelon paving may be considered to eliminate cold longitudinal joints. Tandem paving shall not be performed without prior consent of the project engineer.
- 3.2 If traffic loop detectors are encountered and broken, the Contractor is to repair as per local specifications. The cost for this work will be paid under the loop detector replacement bid item; at negotiated unit prices; or by time and materials as directed by the Engineer. Loops shall be placed after placement of intermediate course and before final pavement course has been installed. Loop replacement shall occur as soon as possible after damage, but no later than 10 days after damage.
- 3.3 Unless otherwise shown on the drawings, jointing of new to existing pavement shall be by milled butt joints per ODOT BP-3.1. Depth of this milled area shall equal the total of subsequent intermediate course and surface course as specified.
- 3.4 One (1) copy of each hauled/weighed material truck load ticket (plant ticket) for materials incorporated in this project shall be provided to the project representative daily. If a partial load is used, the Contractor's foreman and the project representative shall confer and come to an agreement as to what portion of the product was used. The percent of material of this load, as reported by the project representative, is what shall be recorded as utilized.
- 3.5 For variable depth courses where tonnage tickets are used for determining quantities for payment, the conversion to cubic yards shall be number of tons verified and approved by the Engineer divided by 2.00 regardless of the actual density of the mix.
- 3.6 Positive drainage is to exist subsequent to the completion of the surface course. The Contractor shall take any necessary measures to assure positive drainage of the surface course. It shall be the responsibility of the Contractor to repair any low/puddled areas at his own cost by milling out the affected areas to a minimum depth equal to the nominal depth of the course being repaired and replacing with the specified asphalt concrete to grades that will correct the drainage problem.
- 3.7 Surface tolerances for all completed surface courses shall be as noted in ODOT 401.19. This tolerance shall apply regardless of whether or not an intermediate course is installed.

- 3.8 At the direction of the Engineer, periodic weight checks of asphalt concrete in loaded trucks shall be made by the Contractor and verified by the Engineer.
- 3.9 All quality control testing data performed on material incorporated into this project shall be forwarded to the Engineer for review as soon as it is available.
- 3.10 Quantity verification (but not necessarily payment quantity) for all asphalt concrete incorporated into the work shall be by weight tickets as produced by the plant or supplier or other means approved by the Engineer. Tack coat shall be verified by a ticket filled out and signed by the Contractor's tack truck driver based on weights taken or observations of level indicators. All verification tickets are required to be submitted to the Engineer on the day the material is incorporated into the work; however, the Engineer may, at his sole discretion, accept verification tickets for any items up to seven (7) calendar days subsequent to the work being performed. **After that date additional verification tickets for material will not be accepted for consideration of payment.**
- 3.11 No work is to be performed without the presence of the Engineer or his designated Project Representative. Forty-eight (48) hour advance notice of work shall be given to the Engineer and Owner by the Contractor.
- 3.12 **All centerline and lane joints and edges of surface courses abutting curbs, drives, butt joints or other appurtenances shall be sealed with hot AC-20. The material used shall be a certified 702.01 PG binder. The width of sealer shall be 2-3 inches. SS 875 Longitudinal Joint Adhesive shall be used for cold joints in the pavement. Unit pricing of asphalt surface course shall include payment for this joint sealing.**
- 3.13 The duration of time between milling and placement of the intermediate course shall be no longer than 14 days. The time limit shall begin on the first day of planing and shall continue based on calendar days until completion of the asphalt concrete intermediate course.

SECTION 6
STANDARD SPECIFICATIONS

STANDARD SPECIFICATIONS

1. The "Construction and Material Specifications" of the State of Ohio Department of Transportation (ODOT), 2016 edition, ODOT Supplemental Specification 800, and current ODOT supplemental specifications, and current ODOT standard drawings shall govern work and materials which are not specified or modified herein or on the project Contract Drawings. All references to "the Department" shall be changed to "the Owner or his Representative." The project Contract Drawings and Specifications, in the event of a discrepancy, shall supersede the ODOT Specifications.

The absence of an "As Per Plan" designation on some item descriptions in the proposal for which there are clear and controlling plan notes, specifications, or other requirements does not relieve the Contractor of the responsibility to read, bid and construct those particular items in accordance with the governing plan notes, specifications, or other requirements and the Contractor shall have no basis of claim based upon an "order of precedence".

SECTION 7
SPECIFIC PROJECT REQUIREMENTS

SPECIFIC PROJECT REQUIREMENTS

1) General

A preconstruction conference scheduled by the City of Mentor Engineer shall be held prior to any work starting. In addition, the contractor shall provide 48 hours notice to the Mentor City Engineer, the Lake County Sanitary Engineer and Aqua Ohio Water Company prior to beginning work to arrange for inspection.

The improvement plans have been designed in accordance with the applicable rules and regulations of the City of Mentor, as well as the construction and materials specifications of the Ohio Department of Transportation, 2016 edition, including all supplemental specifications and drawings, shall govern this project. For purposes of this plan, references to director or engineer shall be construed to mean the Mentor City Engineer and/or his representative.

All work contemplated shall be governed by the rules, regulations and specifications of the City of Mentor Engineer, the Lake County Sanitary Engineer and Aqua Ohio Water Company and at all times be subject to their direct supervision and inspection.

All work contemplated under this contract shall comply with the U.S. Department of Labor Occupational Safety and Health Act.

2) Material Testing And Permits

The contractor shall be responsible for the cost of all material and equipment testing. The contractor shall be responsible for obtaining all permits required for this project. The executed project contract shall serve to fulfill the City of Mentor's permitting requirements. The contractor shall be registered to work within the City of Mentor prior to beginning construction.

3) Existing Water Main Facilities

The Aqua Ohio Water Company shall be responsible for all relocations of their water main facilities required, including valve box adjustment to grade. The contractor shall be responsible for coordinating his work with Aqua Ohio, Inc. so that completion of his work is not delayed by the water work. The contractor shall notify Aqua Ohio, Inc. At least 48 hours in advance of any work which may affect their system.

4) Utilities

The contractor shall be responsible for notification of the existing utility owners and utility protection service listed below in accordance with section 154.64 of the ORC and as outlined in the project specifications.

The utility ownerships are as follows:

Ohio Utility Protection Service
106 West Ryen, Room 427
Youngstown, Ohio 44051
Phone: (800) 362-2746

City of Mentor Service Department
8500 Civic Center Boulevard
Mentor, Ohio 44060
Phone: (440) 974-5780

First Energy
6896 Miller Road
Brecksville, Ohio 44141
Phone: (440) 546-8804
Mr. William Snyder

AT&T
13630 Lorain Ave., 4th floor
Cleveland, Ohio 44111
Phone: (216) 476-6142
Mr. James Janis

Lake County Utilities Dept.
105 Main Street
Painesville, Ohio 44077
Phone: (440) 350-2652
Mr. Denis Yurkovich

Dominion Energy
320 Springside Drive, Suite 320
Akron, Ohio 44333
Phone: (216) 299-6861
Mr. Theodore Harshman

Orwell Natural Gas
3511 Lost Nation Road
Willoughby, Ohio 44094
Phone: (440) 255-1945
Mr. Keith Krejci

Aqua Ohio, Inc.
8644 Station Street
Mentor, Ohio 44060
Phone: (440) 255-3984 ext 50611
Mr. William Bowers

Charter Spectrum
7820 Division Drive
Mentor, Ohio 44060
Phone: (440) 361-0023
Mr. David Detore

The owner of the underground utility facility shall, within 48 hours, excluding Saturday, Sundays and legal holidays, after notice is received, stake, mark or otherwise designate the location of the underground utility facilities in the construction area in such a manner as to indicate their course together with the approximate depth at which they were installed. The marking or locating shall be coordinated to stay approximately two (2) days ahead of the planned construction.

5) **Subsurface Investigations**

It is the obligation and responsibility of the contractor to make his own investigation of subsurface conditions prior to submitting his proposal.

6) **Drainage Of Roadway Area During Construction**

The contractor shall be required during the course of his work within and adjacent to the existing pavement areas to maintain the roadway area in such condition that it will be well drained and kept dry at all times. The contractor shall be responsible for the thorough drainage of the subgrade surface at all times. The contractor shall be responsible for all additional costs required to correct poor subgrade conditions due to his neglect in properly maintaining subgrade drainage.

7) Notification

The City of Mentor Police, Fire, Public Works Departments, City Engineer and the Mentor Exempted Village Board of Education as well as the Ohio Department of Transportation shall be notified at least one (1) week prior to the actual start of construction.

City of Mentor Police Department:
Kenneth Gunsch, Chief
(440) 974-5760

ODOT District 12 Public Information Office
(PIO)
Fax (216) 584-3524
Email:

City of Mentor Engineer
David A. Swiger, P.E.
(440) 974-5785

d12.publicinformation@dot.state.oh.us

City of Mentor Fire Department
Robert Searles, Chief
(440) 974-5765

Mentor Exempted Village Board of
Education
Director of Transportation
(440) 255-4444

ODOT District 12 Lake County Manager
(440) 354-2191

City of Mentor Department of Public Works
Matthew Schweikert, Director
(440) 974-5780

8) Notification Of Property Owners

The contractor shall notify all residences and businesses along the project route in writing at least forty-eight (48) hours prior to commencing work. Such notice shall include, at a minimum, a brief project description, tentative construction schedule, limits of construction, the contractor's name, address and phone number, as well as a contact person's name and emergency phone number where he could be reached during non-work hours. The notice shall be reviewed and approved by the City of Mentor prior to being distributed. All costs associated with the above shall be included in the lump sum price bid for item 614, Maintaining Traffic.

9) Use of Private Property

The contractor can use private property for the storage of equipment and materials only with a written agreement with the property owner. The contractor shall provide this agreement to the engineer prior to any use of private property.

10) Protection And Restoration Of Property

The contractor shall be responsible for the preservation of all public and private property.

The contractor shall be responsible for all damage or injury to property and/or persons during the prosecution of the work, resulting from any act, omission, neglect or misconduct in his manner or method of executing the work, or at any time due to defective work or materials, and said responsibility will not be released until the project shall have been completed and accepted.

Dust nuisance originating from any operations either inside or outside the right-of-way shall be controlled by the contractor in accordance with local ordinances and regulations at the sole expense of the contractor.

When or where any direct or indirect damage or injury is done to public or private property by or on account of any act, omission, neglect or misconduct in the execution of the work, or in consequence of the nonexecution thereof by the contractor, he shall restore, at his own expense, such property to a condition similar or equal to that existing before such damage or injury was done by repairing, rebuilding or otherwise restoring as may be directed, or shall make good such damage or injury in an acceptable manner.

11) Existing And Proposed Sanitary Sewer Facilities

The contractor shall be responsible for all adjustments to the existing sanitary sewer manholes as called for on the plans, including all costs associated with inspection of sanitary sewer facilities. The contractor shall notify the Lake County Utilities Department at least 48 hours in advance of any work in their system.

All sanitary sewer manholes shall be adjusted in accordance with the rules, standards and specifications of the lake county utilities department and shall be reviewed, tested and approved by the Lake County Utilities Department.

12) Videotaping

The contractor will provide above ground videotaping of all work areas, including the adjacent right of way, prior to the beginning of the work. The contractor shall not start work until such time as the engineer has been provided copies of the videotape in flash drive format. Payment for this item shall be included in the lump sum price bid for preconstruction video, as per plan.

The contractor shall contact the City of Mentor engineer for any questions concerning videotaping requirements.

13) Material Specifications

Material specifications called for on the plans represent the minimum required for each application. The owner may request or the contractor may desire to substitute alternate materials. Any such substitutions must be equivalent in quality to the material called for and must be approved in writing by the approving agencies and the engineer.

14) Removal Items

All items noted on the plans to be removed by the contractor shall become the property of the contractor and shall be disposed of in an appropriate manner by the contractor unless otherwise noted.

15) **Roadway Pavement Replacement**

All pavement replacement should be conducted under suitable weather conditions. The engineer should be notified in advance of any proposed pavement replacement to determine the suitability of weather conditions for pavement replacement. The contractor shall be responsible for maintenance of all roadway and drives prior to final repair.

The contractor shall also be responsible to assist in the preparation and distribution to affected residents a notice of impending construction, the time frame for each phase, the anticipated use of temporary traffic control and the need for caution when exiting their drive. Once approved by the City of Mentor, this notice must be distributed a minimum of seven (7) days prior to the start of work.

The street to be planed and resurfaced by the contractor's forces may be performed according to a schedule to be provided to the City by the contractor at the preconstruction meeting. Upon planing of a street, all resurfacing work, including restoration shall be completed within 2 weeks. Liquidated damages of \$250 per day shall apply for each and every day or portion thereof that the street remains incomplete past the 2 week limit. No planing of a street shall be started from 5:00 pm Thursday to 8:00 am Monday. Any work started must be completed before fall/winter temperatures drop outside of specifications. No work shall be left unfinished over the winter months.

16) **Maintenance Of Traffic Notes**

Item 614 - Maintaining Traffic

All construction traffic control devices used for this project shall conform to the Ohio Manual of Uniform Traffic Control Devices, latest edition, hereinafter referred to as the manual, and shall be furnished, erected, maintained, relocated and removed by the contractor.

The contractor shall furnish and maintain all necessary safeguards, such as barricades, lighting, flaggers, plastic drums, flashing arrow panels and such other traffic control devices as provided in item 614, Maintaining Traffic, so as to avoid damage and/or injury to vehicles and persons using the roadway during construction. Whenever the engineer deems it necessary, he may direct that additional or alternative devices be used. Also, the contractor shall provide sufficient additional barricades, etc. to protect the fresh pavement during the curing period from vehicles which may drive around or through the traffic control. **After planing of pavement the contractor shall ramp around each exposed casting utilizing hot mix asphalt.**

Traffic control devices shall be set up prior to the start of construction and shall be properly maintained during the time such special conditions exist. They shall remain in place only as long as they are needed and shall be immediately removed thereafter. Where operations are performed in phases, there shall be in place only those devices that apply to the condition present during the phase-in progress. All signs with messages which do not apply during a certain period shall be covered or set aside out of the view of traffic. Conflicting pavement markings shall be removed in accordance with section 641.10 of the Ohio specifications before any section of roadway is made available to use by traffic.

All permanent and temporary pavement markings are to be maintained throughout the project. Any damaged or faded pavement markings shall be corrected within eight hours after the contractor's notification of the problem. If weather is not conducive to pavement marking installation then repairs shall be made on the first weather permissive day after notification.

When it is not possible to maintain two (2) lanes of traffic (one in each direction) in the work zone area, the contractor may maintain two-way traffic on one (1) lane by use of flagger operation. At least two (2) lanes shall be opened and maintained during non-work hours. Contractor shall prepare a traffic control plan for this section for review and approval by the City of Mentor.

All work and traffic control devices shall be in accordance with Section 614 of the manual. Payment for all labor, equipment and materials shall be included in the lump sum contract price for item 614, Maintaining Traffic, unless otherwise separately itemized in the plans.

17) Work Hours

The standard work hours for this project shall be between the hours of 7:00 am and 9:00 pm. Work shall not be permitted on Saturday, Sunday, or legal holidays, without written permission of the City of Mentor.

18) Side Street Access

The contractor shall be responsible for maintaining traffic on all intersecting side streets. A plan and construction schedule detailing how the contractor is to maintain access to side streets shall be submitted to the engineer and approved prior to commencing work. All costs associated with maintaining access to the side streets shall be included in the unit price bid for item 614, Maintaining Traffic.

19) Providing Continuous Access To Residences And Businesses

Two weeks prior to the start of work, the contractor shall submit to the engineer a complete schedule of construction operations along with plans showing traffic control for each phase of construction. Included shall be details of the proposed methods to maintain safe and continuous access for passenger vehicles, trucks and safety equipment to all adjoining properties and intersecting streets. These plans shall include all temporary materials necessary to provide safe, adequate drive surfaces to all adjoining properties. The cost for all materials, equipment and labor necessary to provide continuous access shall be included in the lump sum price bid for item 614, Maintaining Traffic. Plans must be submitted to the engineer and approved prior to commencing any work.

Should the engineer, at any time prior to or during construction, deem any part of the contractor's plans for safe and continuous access to residences and businesses inadequate, additional materials, closures and/or diversions shall be required at no additional cost to the city.

20) Failure To Comply

For any failure to comply with provisions for traffic control set out in these plans and notes or with the provisions of the manual, the roadway in the vicinity of the work area shall be considered in a condition unacceptable for the safety and convenient use by the traveling public. Any failure to keep the roadway in the vicinity of the working area in a condition acceptable for the safe and convenient use by the traveling public shall be considered a breach of this contract. Work shall be suspended until the contractor complies with the provisions of the aforementioned items.

21) Item Spec. - Law Enforcement Officer With Patrol Car

This item is intended for use as a contingency item, as directed by the engineer, to provide and pay for all costs associated with the services of a City of Mentor Police Officer with patrol car (equipped with flashing lights) for the exclusive purpose of assisting the contractor in controlling traffic by maintaining a presence at the point(s) of slow-down, stoppage or back-up.

The police officer will be under the direction of the City of Mentor Police Chief. The police officer will periodically supplement, but will not share in the contractor's maintenance of traffic obligations.

For this project it is anticipated that a City of Mentor police officer with patrol car will be required during construction operations at the following specific time periods:

1. Work at the intersection of US 20
2. Work at the intersection of Jackson Street
3. Work at the intersection of Tyler Blvd
4. Work at the intersection of Market Street
5. Whenever the engineer deems it necessary he may direct that a police officer with patrol car be utilized in other locations.

It shall be the contractor's responsibility to make arrangements with the City of Mentor police chief regarding scheduling of a police officer with patrol car. The contractor shall contact Chief Kenneth Gunsch or his designee @ (440)-974-5760. A 72 hour notice is required.

Payment for this item will be on an hourly basis at a rate set in the bid proposal by the City of Mentor. The contractor shall be responsible for this payment and the contractor will be paid the same amount in accordance with the contract. The following estimated quantity has been included in the bid proposal as a contingency item for use as directed by the engineer:

Item Spec. - Law Enforcement Officer with Patrol Car 100 hours

22) **Sequence Of Construction**

Two weeks prior to the start of work, or at the preconstruction meeting, whichever is earlier, the contractor shall submit to the engineer a complete schedule of construction operations along with plans showing traffic control for each phase of construction. Two-way traffic must be maintained on Hopkins Road and all side streets, at all times, during all phases, utilizing flagger operations.

23) **Miscellaneous Construction Notes**

The signal contractor shall contact the City of Mentor Traffic Department for loop locations.

Dave Rorapaugh
Traffic Supervisor
(440) 974-5781

Contractor shall have an ISMA Level 2 Certified Traffic Signal Technician on the job site during performance of any signal related construction operations.

24) **Project Completion**

All work including restoration and clean-up shall be completed no later than the contract completion date. Failure to complete all work within the allotted time will result in assessment of liquidated damages. Upon completion of all work and written notification of same by the Contractor, the Engineer and Owner will compile a punch list. The punch list will be sent to the Contractor. All punch list work shall be completed to the satisfaction of the Engineer and the Owner within 14 days after receipt of the punch list. Failure to complete the punch list work within the allotted time will result in assessment of liquidated damages.

25) **Taxes**

The Contractor shall pay and/or withhold all sales, consumer, use, employment and other taxes (including the City of Mentor 2% income tax) paid or withheld by the Contractor in accordance with the Laws and Regulations of the United States, State of Ohio, and City of Mentor which are applicable during the performance of the work.

26) **Contact During Bidding**

All Questions during bidding should be addressed to Allen E. Pennington, P.E., who can be reached at the City of Mentor Engineering and Building Department, 8500 Civic Center Boulevard, Mentor, Ohio 44060 at (440) 974-5786.

SECTION 8
WAGE RATES

PREVAILING WAGES

Per ODOT 2016 LPA Template, Note 15, US Department of Labor wage scale applies to this project. Refer to the Appendix for this note.

SECTION 9
DRAWINGS

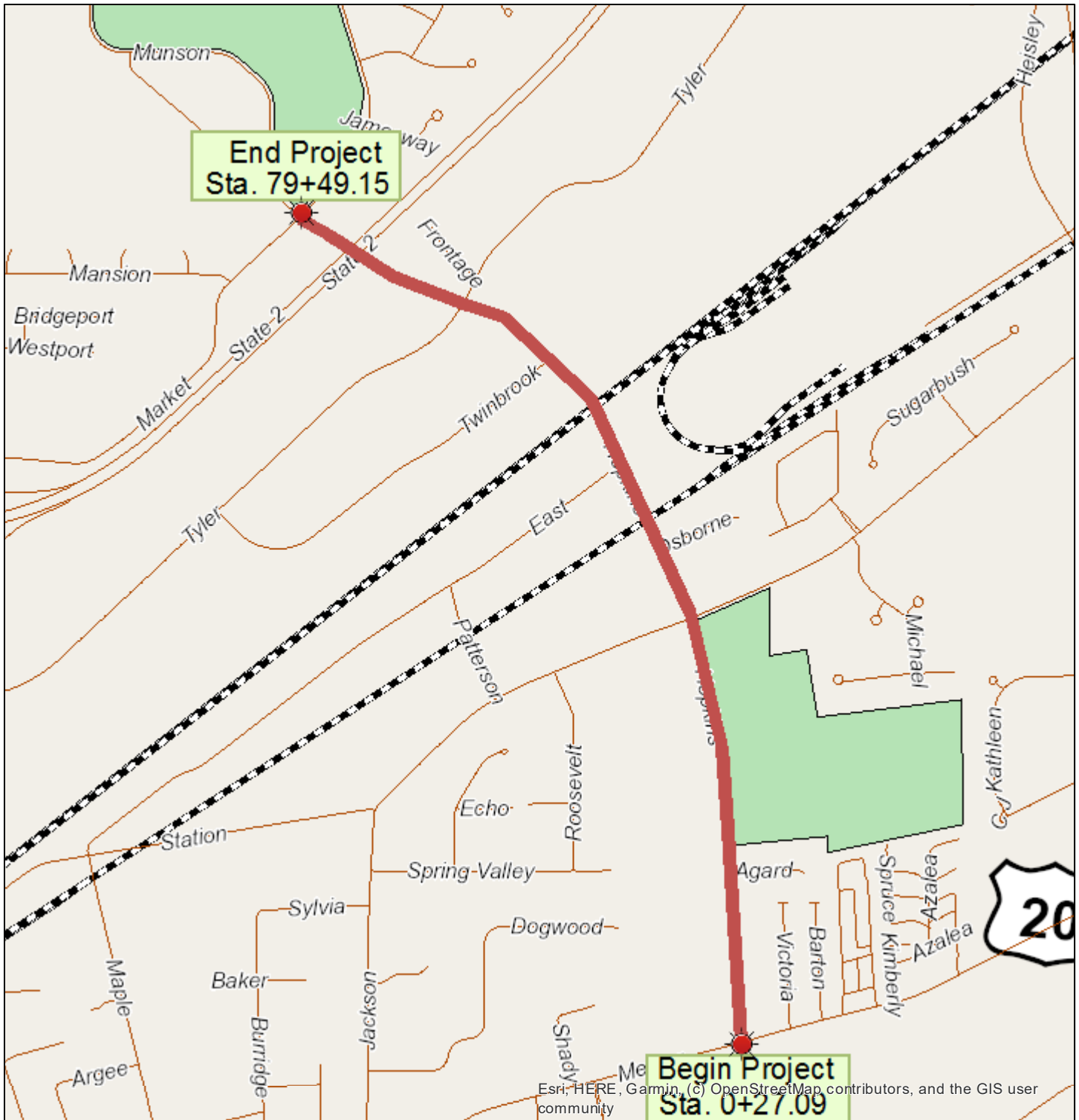

Legend

Points

Override 1

Lines

Override 1

Areas

Override 1

Roadcenterline

Mentor Marsh

Mentor Lagoon
Marina

Scale: 1 inch = 1,505 feet

The City of Mentor and their employees assume no responsibility for the consequences of inappropriate uses or interpretations of the data. All critical information should be independently verified.

Property lines are graphic representations and are not survey accurate.
City of Mentor
City of Mentor

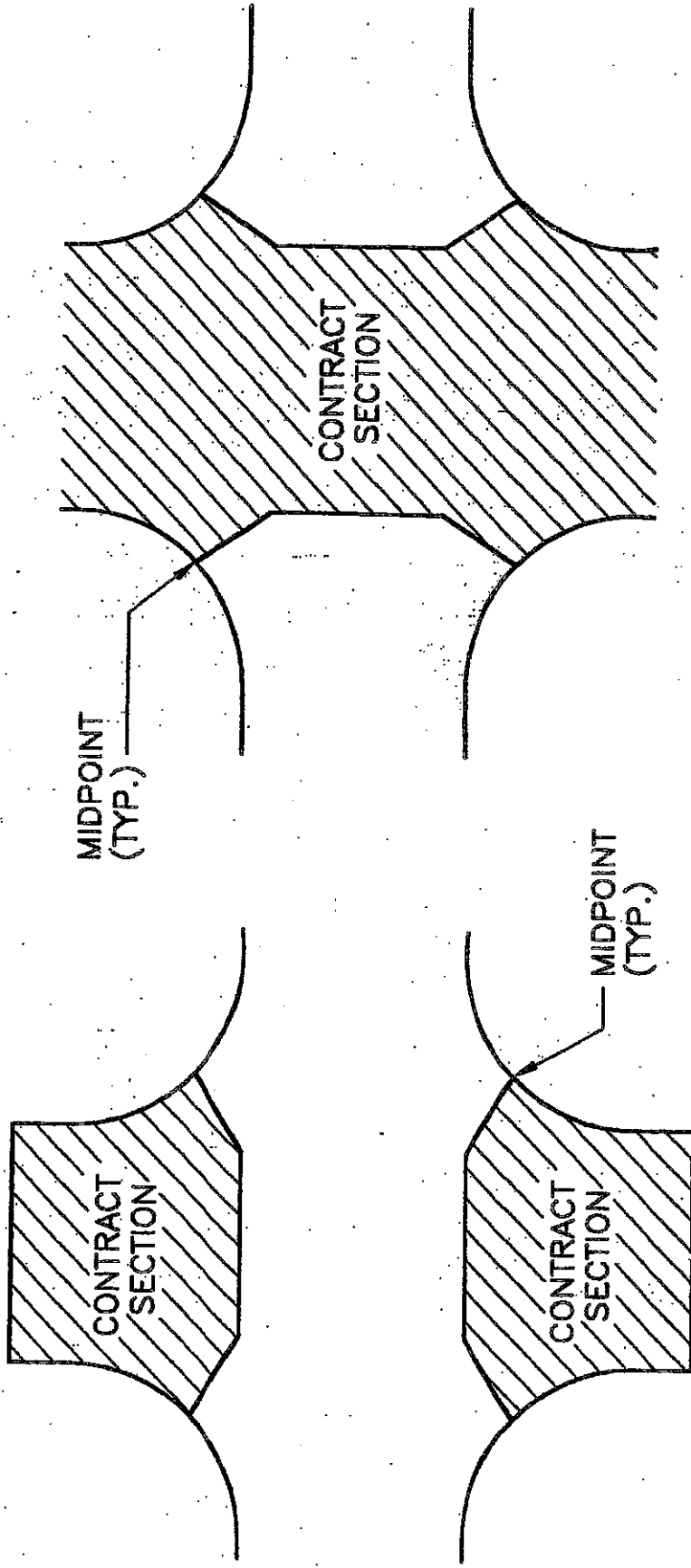

TYPICAL GRINDING AT INTERSECTIONS

N.T.S.

NOTE: ACTUAL GRINDING LIMITS WILL BE MARKED IN THE FIELD BY THE ENGINEER.

1/4" ± 1/16" WIDE SAWED JOINT
WITH O.D.O.T. ITEM 705.04
SEALER OR 705.11 PREFORMED
SEALER. SAW DEPTH T/4.

SEE O.D.O.T. STANDARD
DRAWING BP-4

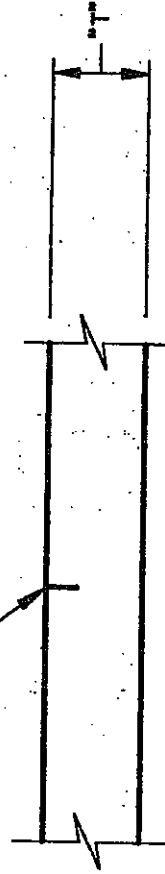

CONTRACTION JOINT

SEPERATELY PLACED LANES

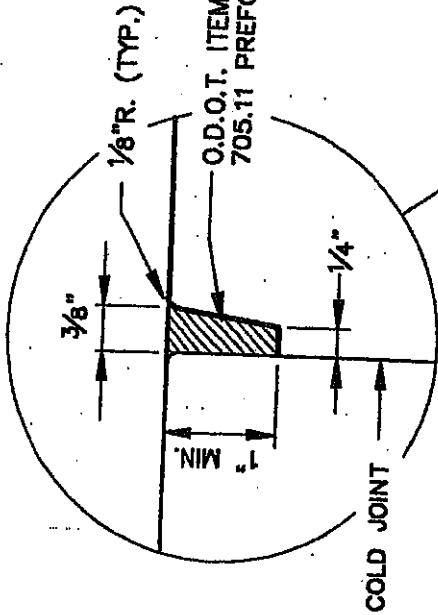

SIMULTANEOUSLY PLACED LANES

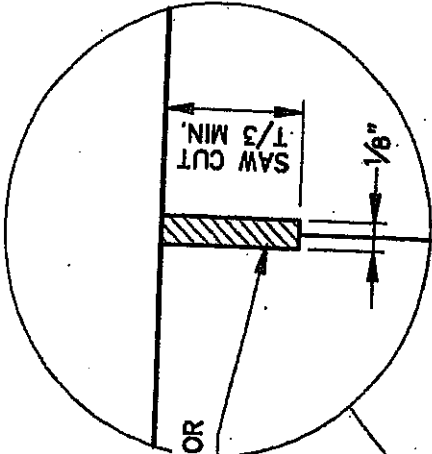

5/8" TIE BAR - 30" ON CENTERS

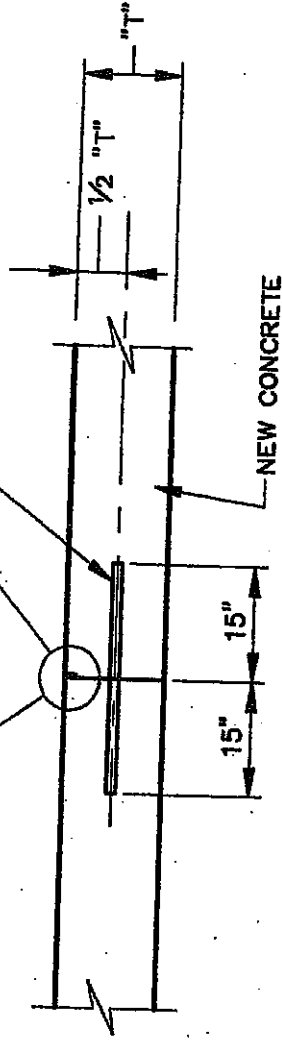

NOTE:
SEE O.D.O.T. STANDARD DRAWING BP-3
FOR ALTERNATE BUTT JOINT DETAILS.

(TOTALLY NEW CONSTRUCTION)
LONGITUDINAL BUTT JOINT

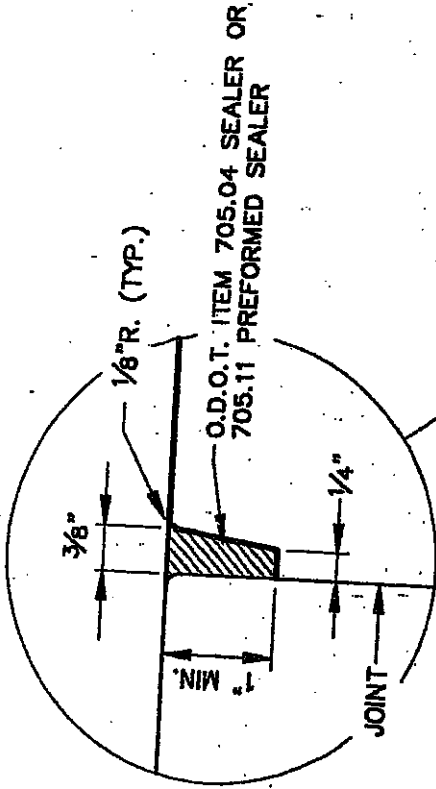

18" LONG SMOOTH DOWEL 12" O.C.
DIA. = 1" FOR "T" ≤ 8" AND 1 1/4"
FOR "T" > 8". GREASE OR OIL END
OF DOWEL IN NEW CONCRETE.

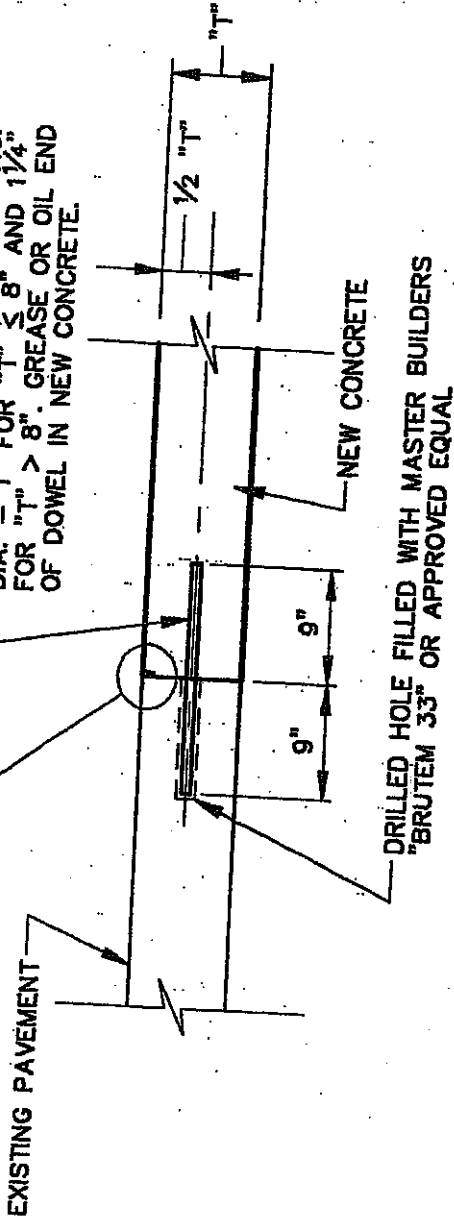

TRANSVERSE BUTT JOINT

SEE O.D.O.T. STANDARD
DRAWING BP-4

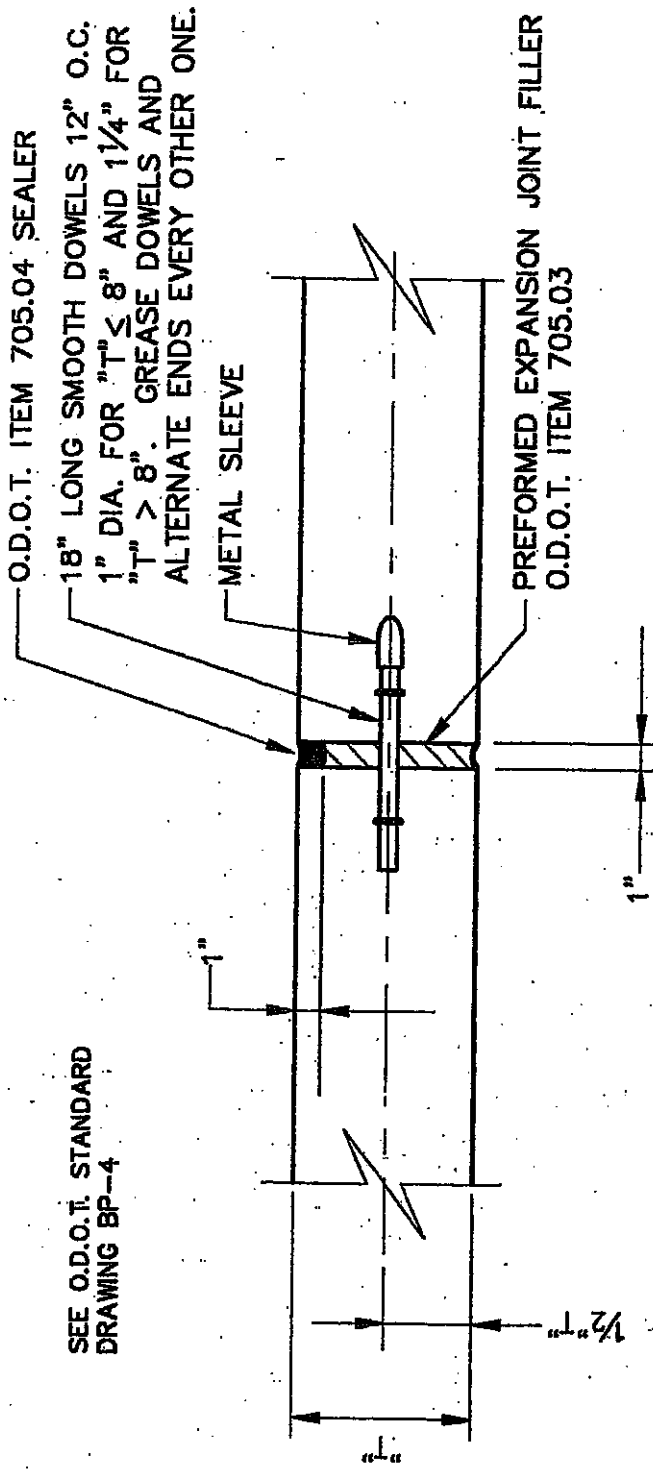

NOTE: EXPANSION JOINTS SHALL BE USED AT ALL INTERSECTIONS AND WHERE DESIGNATED ON THE PLANS OR BY THE ENGINEER.

EXPANSION JOINT

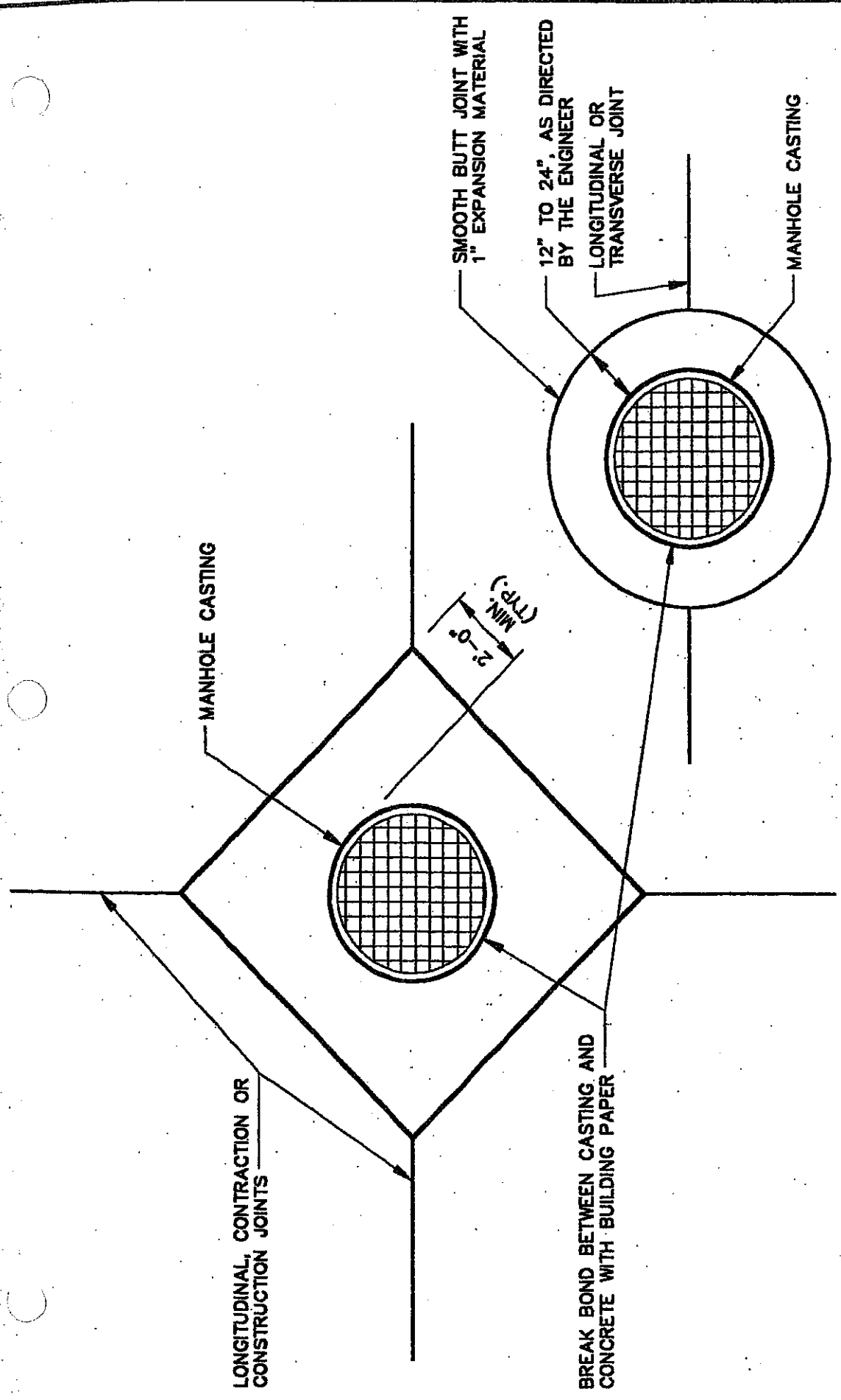

MANHOLE BOX-OUT DETAIL
(N.T.S.)

NOTE A:

ALTERNATE INLET BOX-OUT TO BE USED WHERE RECTANGULAR BOX-OUT DOES NOT FIT PAVEMENT JOINT PATTERN OR WHERE DIRECTED BY ENGINEER. JOINT TO BE A SMOOTH BUTT JOINT WITH 1" EXPANSION MATERIAL. DELETE SMOOTH DOWEL BARS AND CAPS. * = 12" TO 24", AS DIRECTED BY ENGINEER.

NOTE: ALSO APPLICABLE WHERE ROLL CURBS EXIST

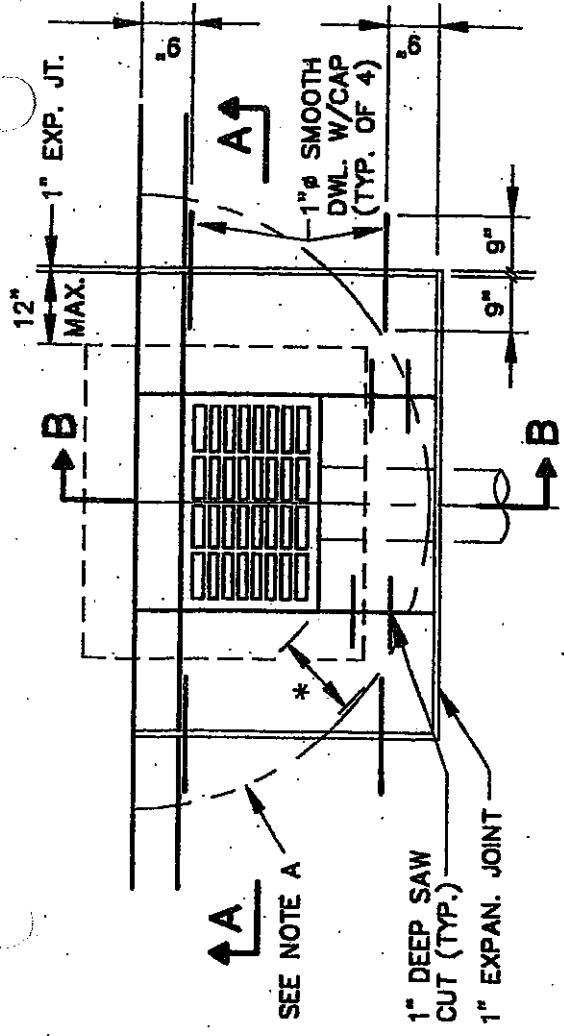

PLAN

2" LOCAL DEPRESSION WITHIN BOX-OUT AREA
PLAN STATION

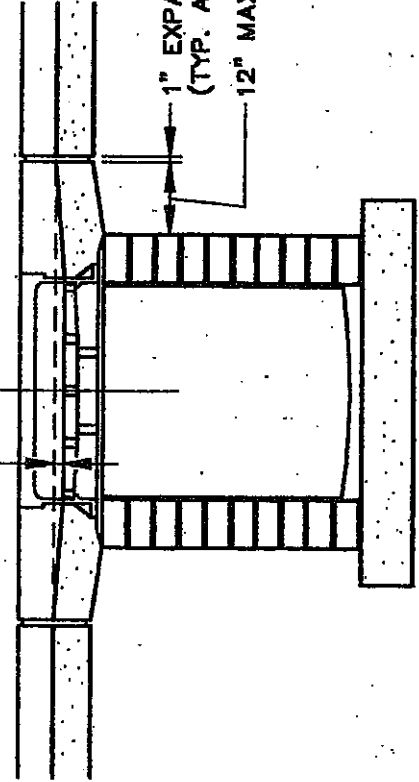

SECTION A - A

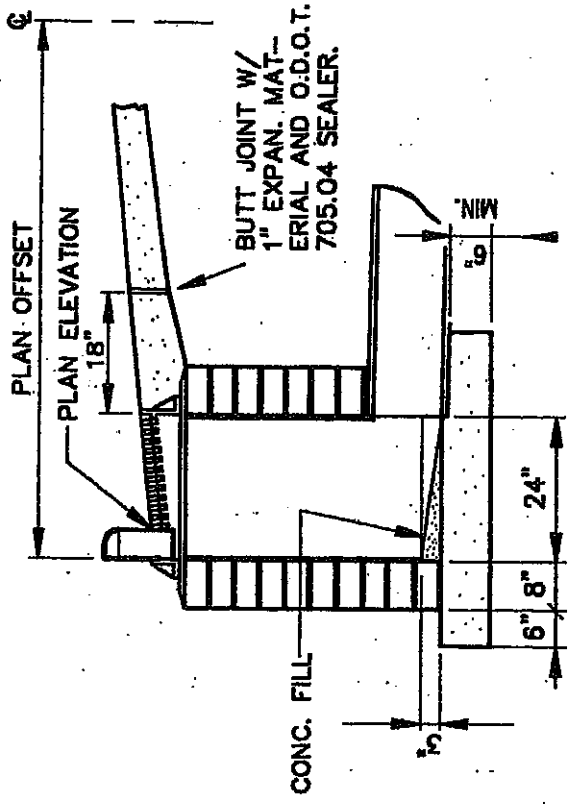

SECTION B - B

CURB INLET BOX-OUT DETAIL

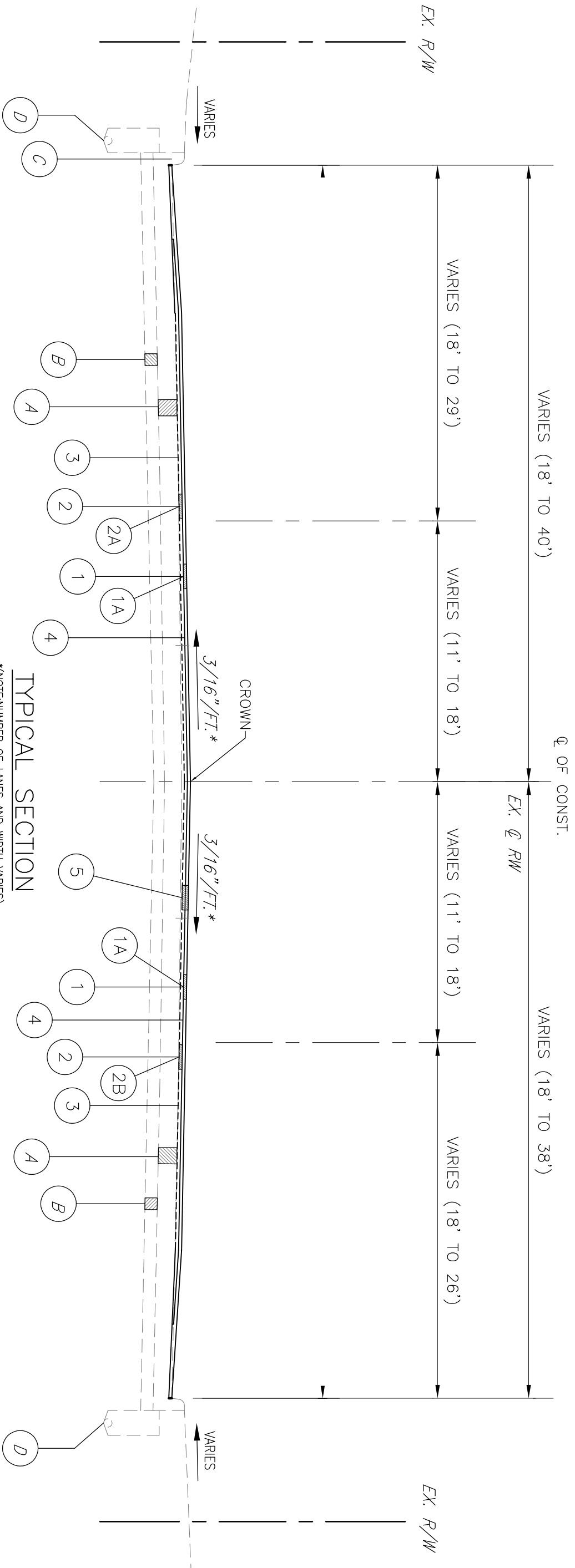

* NOTE: MATCH EXISTING GRADE IN SUPERELEVATED SECTIONS
 STA. 0+27.09 TO STA. 79+36.03
 *(NOTE: NUMBER OF LANES AND WIDTH VARIES)

- ① ITEM 441 - 1 1/2" ASPHALT CONCRETE SURFACE COURSE, TYPE 1, (448) PG 70-22M
- ①A ITEM 442 - 1 1/2" ASPHALT CONCRETE SURFACE COURSE, 12.5MM, TYPE A (448), PG 70-22M, AS PER PLAN. (STA. 76+05.51 TO STA. 79+36.03)
- ② ITEM 441 - 1 1/4" ASPHALT CONCRETE INTERMEDIATE COURSE TYPE 1, (448) PG 64-22
- ②A ITEM 442 - 1 1/2" ASPHALT CONCRETE INTERMEDIATE COURSE, 12.5MM, TYPE A (448), PG 70-22M, AS PER PLAN. (STA. 76+05.51 TO STA. 79+36.03)
- ③ ITEM 407 - TACK COAT, 702.13 FOR CONCRETE BASE AND LEVELING (0.1 GAL/SY)
- ④ ITEM 407 - TACK COAT, TRACKLESS, FOR INTERMEDIATE COURSE (0.05 GAL/SY)
- ⑤ ITEM 254 - PAVEMENT PLANING, BITUMINOUS, AS PER PLAN (2 3/4"), (3" - STA. 76+05.51 TO STA. 79+36.03)

EXISTING LEGEND

- Ⓐ EXISTING PAVEMENT
- Ⓑ EXISTING AGGREGATE BASE
- Ⓒ CURB, WHERE APPLICABLE
- Ⓓ 4" SHALLOW UNDERDRAIN

TYPICAL SECTION

STANDARD CONSTRUCTION DRAWINGS	SUPPLEMENTAL SPECIFICATIONS
BP-1.1 7-28-00	MGS-2.1 1-19-18 800 1-17-20
BP-2.1 7-17-15	MGS-4.1 1-20-17 832 10-19-18
BP-2.2 7-18-08	
BP-3.1 1-17-20	TC-71.10 1-19-18
BP-5.1 1-18-19	
BP-7.1 7-20-18	TC-82.10 7-19-19
RM-1.1 7-18-14	
	MT-95.31 7-19-19
	MT-95.32 4-19-19
	MT-99.20 4-19-19

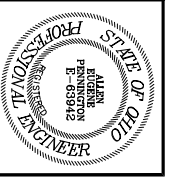







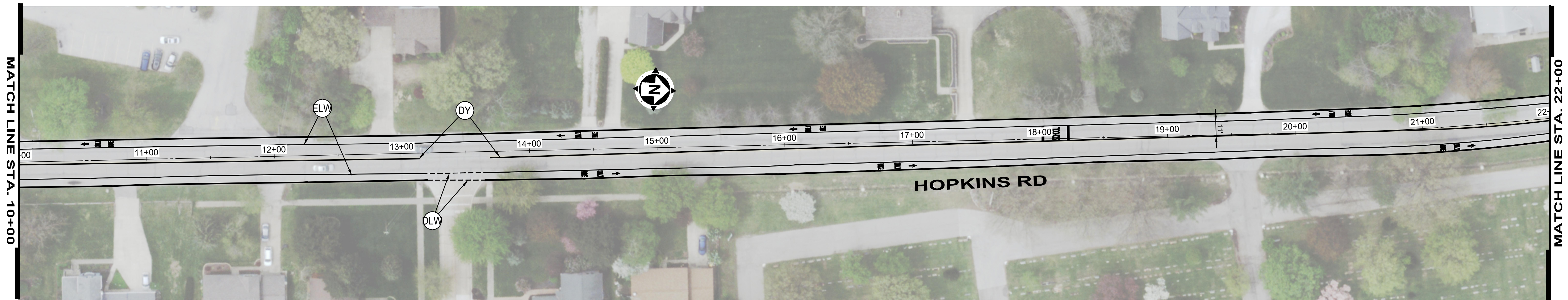
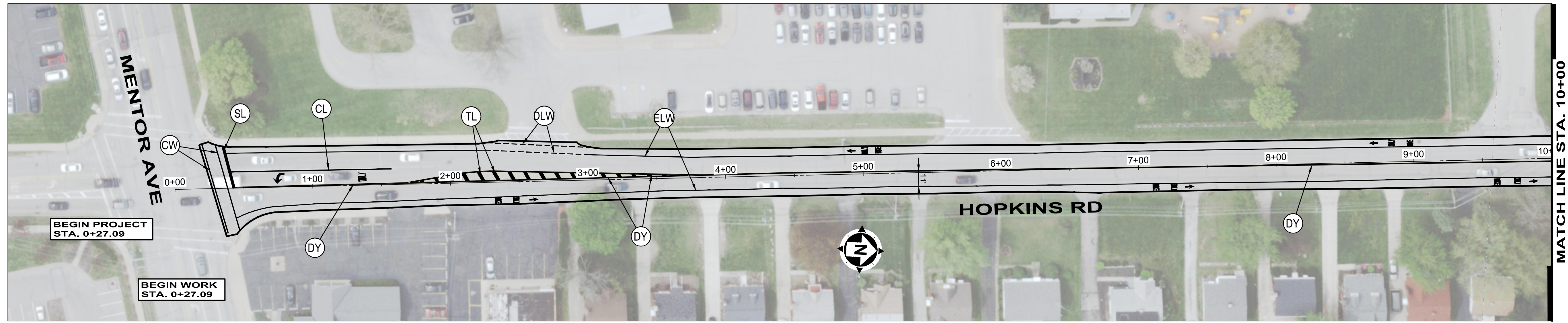



HOPKINS ROAD RESURFACING
 The City of Mentor, Ohio
 TYPICAL SECTIONS

City of Mentor
 8500 Civic Center Drive
 Mentor, OH 44060
 (440) 974-5781

DATE: 08/19/2020
 DRAWN BY: JCM
 CHECKED BY: AEP
 APPROVED BY: AEP
 F.B. No. Pg.
 SCALE:
 HOR. SCALE:
 VERT. SCALE:
 CONTRACT No.
 SHEET NO. OF
 T-1



LEGEND

-  - CHANNELIZING LINE
-  - DOUBLE YELLOW LINE
-  - LANE LINE
-  - STOP BAR
-  - TRANSVERSE LINE
-  - YELLOW ISLAND
-  - CROSSWALK LINE
-  - DOTTED LINE, 4 INCH
-   - EDGE LINE (WHITE OR YELLOW)

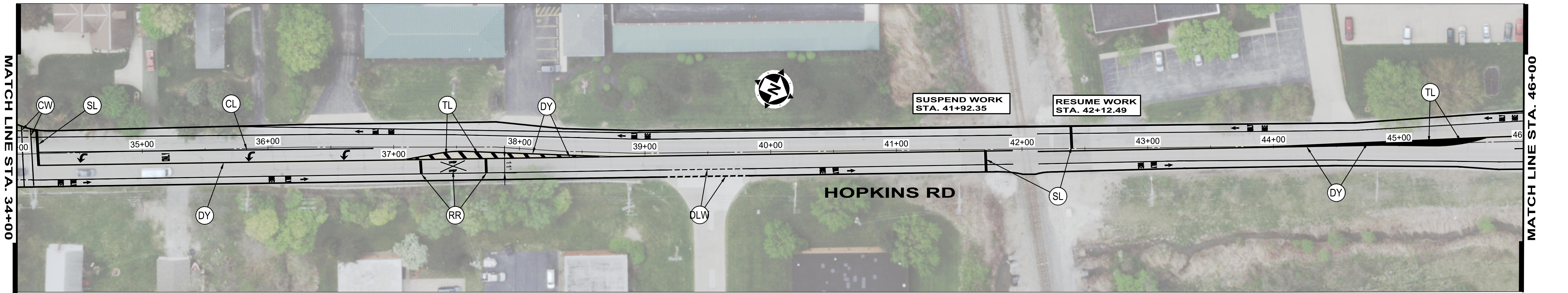
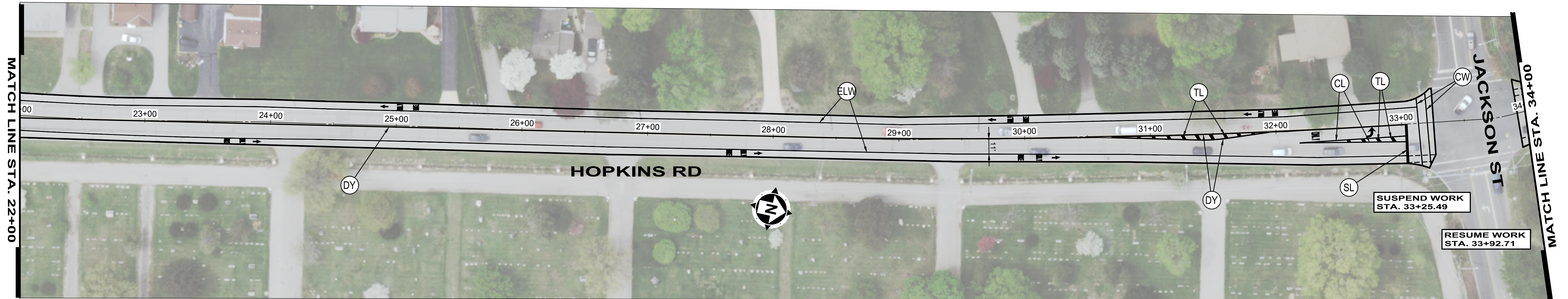

LEGEND

- (CL) - CHANNELIZING LINE
- (DY) - DOUBLE YELLOW LINE
- (LL) - LANE LINE
- (SL) - STOP BAR
- (TL) - TRANSVERSE LINE
- (YI) - YELLOW ISLAND
- (CW) - CROSSWALK LINE
- (DLW) - DOTTED LINE, 4 INCH
- (ELW) (ELY) - EDGE LINE (WHITE OR YELLOW)
- (RR) - RAILROAD CROSSING

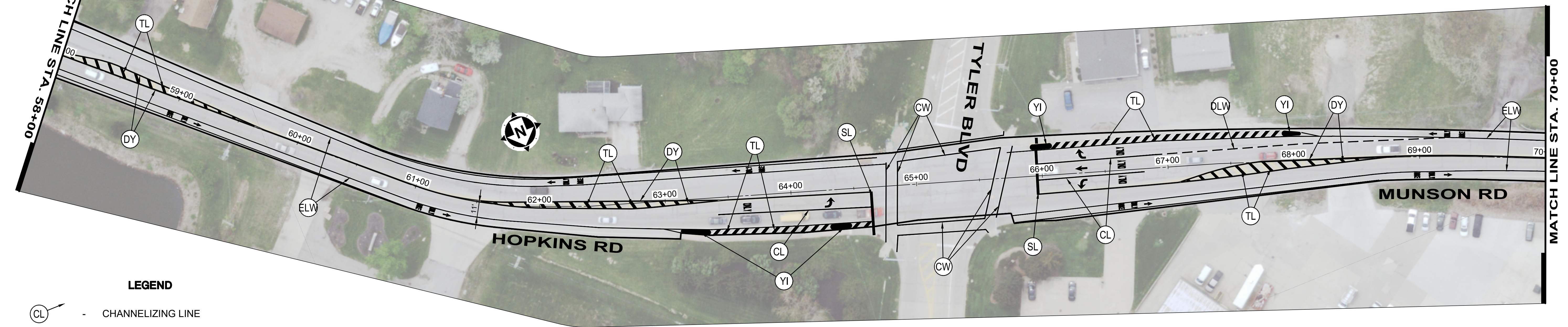
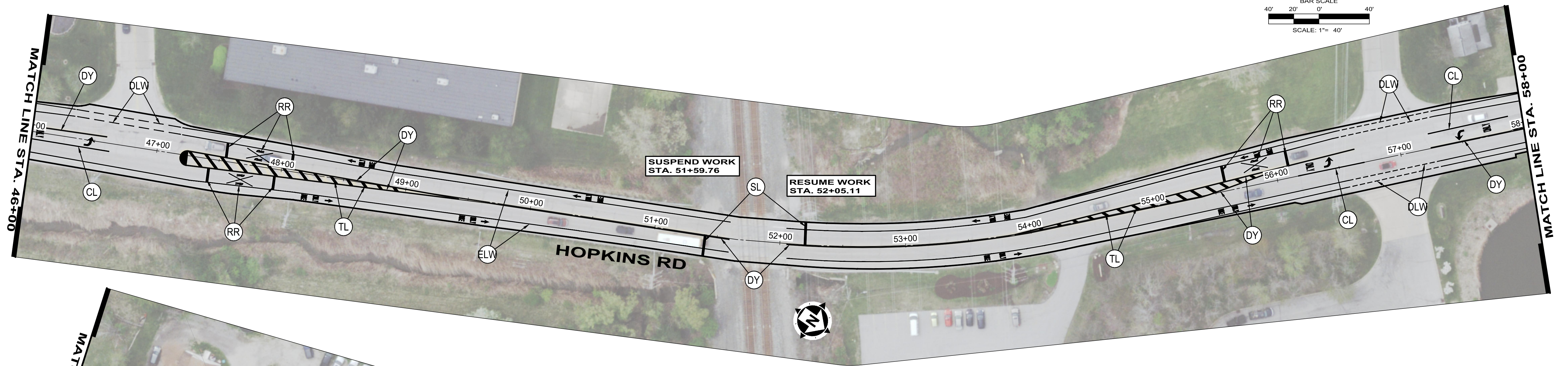

- LEGEND**
- (CL) - CHANNELIZING LINE
 - (DY) - DOUBLE YELLOW LINE
 - (LL) - LANE LINE
 - (SL) - STOP BAR
 - (TL) - TRANSVERSE LINE
 - (YI) - YELLOW ISLAND
 - (CW) - CROSSWALK LINE
 - (DLW) - DOTTED LINE, 4 INCH
 - (ELW) (ELY) - EDGE LINE (WHITE OR YELLOW)
 - (RR) - RAILROAD CROSSING

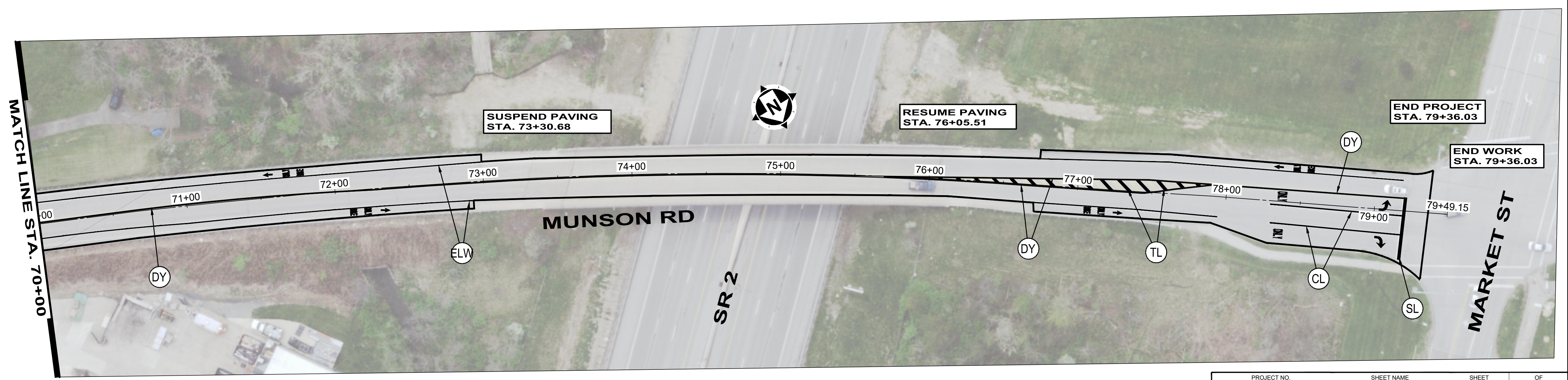

APPENDIX

QUANTITY CALCULATIONS

(FOR INFORMATIONAL PURPOSES ONLY)

QUANTITY WORKSHEET

For LAK - Hopkins Road Rehabilitation (2 3/4" Asphalt Pavement Planing/2 3/4" Asphalt Resurfacing - 3" Planing/Resurfacing STA 76.05.51 to STA 79+36.03)

REF. NO.	DESCRIPTION	ESTIMATED TOTAL QTY.	MEASURE UNITS	HOPKINS- US 20 TO MARKET		
				PAGE 1	PAGE 2	PAGE 3
1	(253) PAVEMENT REPAIR, AS PER PLAN	**2500	SQ YD			
2	(254) PAVEMENT PLANING, BITUMINOUS, AS PER PLAN	34,200.00	SQ YD	8,933.00	10,085.00	15,182.00
3	(407) TACK COAT, 702.13	3,420.00	GALLON	893.30	1,008.50	1,518.20
4	(407) TACK COAT, TRACKLESS, FOR INTERMEDIATE COURSE	1,710.10	GALLON	446.70	504.30	759.10
5	(441) ASPHALT CONCRETE INTERMEDIATE COURSE, TYPE 1, (448), PG64-22 (1 1/4")	1,125.24	CU YD	310.20	350.20	464.84
6	(441) ASPHALT CONCRETE SURFACE COURSE, TYPE 1, (448), PG70-22M (1 1/2")	1,350.16	CU YD	372.20	420.20	557.76
7	(608) 4" CONCRETE WALK	**500	SQ YD			
8	(608) CURB RAMP, AS PER PLAN	*13	EACH	5.00	6.00	2.00
9	(611) MANHOLE/INLET BASIN ADJUSTED TO GRADE	30.00	EACH	18.00	7.00	5.00
10	(611) MONUMENT BOX ADJUSTED TO GRADE, AS PER PLAN	9.00	EACH	3.00	3.00	3.00
11	(614) LAW ENFORCEMENT OFFICER WITH PATROL CAR, AS PER PLAN	100.00	HOUR			
12	(614) PORTABLE CHANGEABLE MESSAGE SIGN	4.00	MONTH			
13	(614) MAINTAINING TRAFFIC	1.00	LUMP			
14	(614) WORK ZONE CENTER LINE, CLASS 1	1.83	MILE	0.45	0.52	0.86
15	(614) WORK ZONE CHANNELIZING LINE, CLASS 1	1,447.00	L.F.	121.00	435.00	891.00
16	(632) DETECTOR LOOP, POWER HEAD, 6' X 30'	14.00	EACH	2.00	4.00	8.00
17	(642) CENTER LINE	1.83	MILE	0.45	0.52	0.86
18	(642) EDGE LINE	2.88	MILE	0.83	0.91	1.14
19	(642) EDGE LINE, 6"	2.99	MILE	0.83	0.91	1.25
20	(642) SCHOOL SYMBOL MARKING 96"	1.00	EACH	1.00		
21	(642) RAILROAD MARKING MARKING 96"	4.00	EACH		1.00	3.00
22	(642) CHANNELIZING LINE	1,447.00	L.F.	121.00	435.00	891.00
23	(642) STOP LINE	340.00	L.F.	30.00	94.00	216.00
24	(642) CROSSWALK LINE	684.00	L.F.	145.00	190.00	349.00
25	(642) TRANSVERSE LINE	833.00	L.F.	43.00	87.00	703.00
26	(642) LANE ARROW	14.00	EACH	1.00	4.00	9.00
27	(642) BIKE LANE MARKING	44.00	EACH	12.00	13.00	19.00
28	(642) WORD "ONLY" ON PAVEMENT	12.00	EACH	1.00	2.00	9.00
29	(642) ISLAND MARKING	52.00	SF			52.00
30	(SPC) BONDS AND INSURANCES, AS PER PLAN	1.00	LUMP			
31	(SPC) PRE-CONSTRUCTION VIDEO, AS PER PLAN	1.00	LUMP			
32	(624) MOBILIZATION	1.00	LUMP			
33	(442) ASPHALT CONCRETE INTERMEDIATE COURSE, 12.5mm, TYPE A, (448), PG70-22M (1 1/2")	72.84	CU YD			72.84
34	(442) ASPHALT CONCRETE SURFACE COURSE, 12.5mm, TYPE A, (448), PG70-22M (1 1/2")	72.84	CU YD			72.84
35	CONTINGENCY	1.00	LUMP			

* Estimated quantity from field review

** Estimated quantities based upon project length - Final locations to be determined in the field

ODOT LPA FEDERAL TEMPLATE

**ODOT’s LPA Template (ODOT Spec Book and LPA Spec Book)
Required Contract Provisions.**

1. ODOT’S 2019 CONSTRUCTION AND MATERIAL SPECIFICATIONS (C&MS) AND ITS SUPPLEMENTS

With the exception of Section 100 “General Provisions” included in the matrix below, ODOT’s Construction and Material Specifications (CM&S) and its supplements are hereby incorporated by reference, in their entirety, as if rewritten herein. The incorporation of this document by reference does not interfere with the order of precedence set forth in Section 105.04 of the CMS Manual.

In accordance with the Locally Administrated Transportation Projects Manual of Procedures (LATPM), when bidding this project, the Contractor should replace the terms “the Department”, “the Engineer”, “the DCE” and “the DCA” with the term “the Local Public Agency (LPA).” Furthermore, nothing in this document is intended to alter the LPA’s adherence to Ohio Revised Code, local ordinance or other applicable requirements which are properly established.

Excluded 2019 Specifications			
Section 102.01	Section 103.01	Section 105.19	
Section 102.03	Section 103.02	Section 107.04	
Section 102.06	Section 103.04	Section 107.13	
Section 102.09	Section 103.05	Section 108.01	
Section 102.10	Section 103.06	Section 108.02(B)	
Section 102.11	Section 103.07	Section 108.02(E)	
Section 102.13	Section 104.02(A)	Section 108.02(G)	
Section 102.17	Section 105.05	Section 108.08	

2. STEEL AND IRON PRODUCTS MADE IN THE UNITED STATES

Furnish steel and iron products that are made in the United States according to the applicable provisions of Federal regulations stated in 23 CFR 635.410 and State of Ohio laws, and ORC 153.011 and 5525.21. “United States” means the United States of America and includes all territory, continental or insular, subject to the jurisdiction of the United States. Both the State and Federal requirements contained in (A.) and (B.) of this section apply to this contract.

A. Federal Requirements. All steel or iron products incorporated permanently into the Work must be made of steel or iron produced in the United States and all subsequent manufacturing must be performed in the United States. Manufacturing is any process that modifies the chemical content; physical shape or size; or final finish of a product. Manufacturing begins with the initial melting and mixing and continues through the bending and coating stages. If a domestic product is taken out of the United States for any process, it becomes a foreign source material.

B. State Requirements. All steel products used in the Work for load-bearing structural purposes must be made from steel produced in the United States. State requirements do not apply to iron.

C. Exceptions. ODOT may grant specific written permission to use foreign steel or iron products in bridge construction and foreign iron products in any type of construction. ODOT may grant such exceptions under either of the following conditions:

1. The cost of products to be used does not exceed 0.1 percent of the total Contract cost, or \$2,500, whichever is greater. The cost is the value of the product as delivered to the project.

2. The specified products are not produced in the United States in sufficient quantity or otherwise are not reasonably available to meet the requirements of the Contract Documents. ODOT may require the Contractor to obtain letters from three different suppliers documenting the unavailability of a product from a domestic source, if the shortage is not previously established.

D. Proof of Domestic Origin. Furnish documentation to the Engineer showing the domestic origin of all steel and iron products covered by this section, before they are incorporated into the Work. Products without a traceable domestic origin will be treated as a non-domestic product.

3. CERTIFICATION AGAINST DEBARMENT AND SUSPENSION

The bidder hereby certifies by signing this proposal that, except as noted below, under penalty of perjury and under other such penalties as the laws of this state and the United States of America provide, that the company or any person associated there with in the capacity of owner, partner, director, officer, principal investigator, project director, manager, auditor, or any position involving the administration of federal funds is **not** currently under suspension, debarment, voluntary exclusion or determination of ineligibility by any federal agency; that the company or any person associated therewith in the capacity of owner, partner, director, officer, principal investigator, project director, manager, auditor, or any position involving the administration of federal funds has **not** been suspended, debarred, voluntarily excluded or determined ineligible by any federal agency within the past three (3) years; that the company or any person associated therewith in the capacity of owner, partner, director, manager, auditor, or any position involving the administration of federal funds does **not** have a proposed debarment pending; that the company or any person associated there with in the capacity of owner, partner, director, officer, principal investigator has **not** been indicted, convicted, or had a civil judgment rendered against the company, or themselves by a court of competent jurisdiction in any matter involving fraud or official misconduct within the past three (3) years.

If there are exceptions to any of the above clauses, please include a statement with the bid package detailing these exceptions.

Exceptions will not necessarily result in denial of award but will be considered in determining bidder responsibility. For any exception noted, indicate below to whom it applies, initiating agency and dates of action. Providing false information may result in criminal prosecution or administrative sanctions. Execution of this proposal on the signature portion thereof shall constitute also signature of this certification as permitted by Title 28 United States Code, Section 1746.

4. PREQUALIFICATION

Only pre-qualified contractors are eligible to submit bids for this PROJECT. Pre-qualification status must be in force **at the time of bid, at the time of award, and through the life of the construction contract.** For work types that ODOT does not pre-qualify, the LPA must still select a qualified contractor. Subcontractors are not subject to the pre-qualification requirement. The “prime” contractor must perform no less than 30 percent of the total original contract price.

5. PN033 - 4/18/2008- AS PER PLAN DESIGNATION

(Not required by FHWA, but strongly suggested if As Per Plan is used by the LPA)

For the last several years the “As Per Plan” designation has been added to some item descriptions in the proposal to assist the Contractors to easily identify standard items that have been altered by plan notes.

The “As Per Plan” designation has proven to be a very useful tool for the Contractors. However, its use was never intended to relieve the Contractors of their responsibility to read, bid and construct all items in accordance with all governing plan notes. Therefore, the absence of an “As Per Plan” designation on some item descriptions in the proposal for which there are clear and controlling plan notes does not relieve the Contractors of the responsibility to read, bid and construct those particular items in accordance with the governing plan notes.

Be advised that the item descriptions in the bidding proposal must be read or interpreted with the governing plan notes and the Construction and Material Specification Manual. A claim based upon an "order of precedence" basis will be denied. In the event that a conflict, either real or perceived, exists between the item description and the governing plan note, the Contractors are to request clarification through the pre-bid process.

6. **FEDERALLY REQUIRED EEO CERTIFICATION FORM**

The bidder hereby certifies that he **has**, **has not**, participated in a previous contract or subcontract subject to the equal opportunity clause, as required by Executive Orders 10925, 11114, or 11246, and that he **has**, **has not**, filed with the Joint Reporting Committee, the Director of the Office of Federal Contract Compliance, a Federal Government Contract Compliance, a Federal Government contracting or administering agency, or the former President's Committee on Equal Employment Opportunity, all reports due under the applicable filing requirements. **The Bidder must circle the appropriate "has or has not" above.**

7. **PN 017 - 10/15/2004 - FEDERALLY REQUIRED EEO CERTIFICATION CLAUSE**

The Federally Required EEO Certification is required by the Equal Employment Opportunity Regulations of the Secretary of Labor (41 CFR 60-1.7 (b) (1)) and must be submitted by bidders and proposed subcontractors only in connection with contracts and subcontractors which are subject to the equal opportunity clause. Contracts and subcontracts which are exempt from the equal opportunity clause are set forth in 41 CFR 60-1.5. (Generally only contracts or subcontracts of \$10,000 or under are exempt.)

Currently, Standard Form 100 (EEO-1) is the only report required by the Executive Orders or their implementing regulations.

Proposed prime contractors and subcontractors who have participated in a previous contract or subcontract subject to the Executive Orders and have not filed the required reports should note that 41 CFR 60-1.7 (b) (1) prevents the award of contracts and subcontracts unless such contractor submits a report covering the delinquent period or such other period specified by the Federal Highway Administration or by the Director, Office of Federal Contract Compliance, U.S. Department of Labor.

8. **PN 026 - 10/15/2004 - CERTIFICATION OF NONSEGREGATED FACILITIES**

(a) Certification of Nonsegregated Facilities, as required by the May 9, 1967, Order of the Secretary of Labor (32 F.R. 7439, May 19, 1967) on Elimination of Segregated Facilities (for a Federal-aid highway construction contract exceeding \$10,000 which is not exempt from the provisions of the Equal Opportunity clause).

(b) Bidders are cautioned as follows: By signing this bid, the bidder has agreed to the provisions of the "Certification of Nonsegregated Facilities" in this proposal. This certification provides that the bidder does not maintain or provide for his employees' facilities which are segregated on a basis of race, creed, color, or national origin, whether such facilities are segregated by directive or on a de facto basis. The certification also provides that the bidder will not maintain such segregated facilities.

(c) Bidders receiving Federal-aid highway construction contract awards exceeding \$10,000 which are not exempt from the provisions of the Equal Opportunity clause, will be required to provide for the forwarding of the following notice to prospective subcontractors for construction contracts and material suppliers where the subcontracts or material supply agreements exceed \$10,000 and are not exempt from the provisions of the Equal Opportunity clause.

"Notice to Prospective Subcontractors and Material Suppliers of Requirement for Certification of Nonsegregated Facilities" -

- (a) A Certification of Nonsegregated Facilities as required by the May 9, 1967, Order of the Secretary of Labor (32 F.R. 7439, May 19, 1967) on Elimination of Segregated Facilities, which is included in the proposal, or attached hereto, must be submitted by each subcontractor and material supplier prior to the award of the subcontract or consummation of a material supply agreement if such subcontract or agreement exceeds \$10,000 and is not exempt from the provisions of the Equal Opportunity clause.
- (b) Subcontractors and material suppliers are cautioned as follows: By signing the subcontract or entering into a material supply agreement, the subcontractor or material supplier will be deemed to have signed and agreed to the provisions of the "Certification of Nonsegregated Facilities" in the subcontract or material supply agreement. This certification provides that the subcontractor or material supplier does not maintain or provide for his employees facilities which are segregated on the basis of race, creed, color, or national origin, whether such facilities are segregated by directive or on a de facto basis. The certification also provides that the subcontractor or material supplier will not maintain such segregated facilities.
- (c) Subcontractors or material suppliers receiving subcontract awards or material supply agreements exceeding \$10,000 which are not exempt from the provisions of the Equal Opportunity clause will be required to provide for the forwarding of this notice to prospective subcontractors for construction contracts and material suppliers where the subcontracts or material supply agreements exceed \$10,000 and are not exempt from the provisions of the Equal Opportunity clause.

9. PN 003 - 10/15/2004 - TITLE VI RELATED STATUTES NON-DISCRIMINATION STATEMENT

The LPA, under Title VI of the Civil Rights Act and related statutes, ensures that no person in the LPA, shall on the grounds of race, color, national origin, sex, disability or age be excluded from participation in, be denied the benefits of, or be otherwise subjected to discrimination under any program or activity it administers.

10. CERTIFICATION OF COMPLIANCE WITH AFFIRMATIVE ACTION PROGRAMS

In accordance with Ohio Administrative Code §9.47, before any Contract is awarded, the LPA will require the Bidder to furnish a valid Certificate of Compliance with Affirmative Action Programs, issued by the State EEO Coordinator dated prior to the date fixed for the opening of bids.

11. PN 020 – 11/21/2011 - NOTICE OF REQUIREMENT OF AFFIRMATIVE ACTION TO ENSURE EQUAL EMPLOYMENT OPPORTUNITY

The Bidder's attention is called to the affirmative action obligations required by the specifications set forth in 23 CFR Part 230, 41 CFR Part 60, Executive Order 11246, Section 503, and the affirmative action provisions of Vietnam Era Veterans' Readjustment Assistance Act (VEVRAA) of 1974.

Utilization goals applicable to the project, expressed in percentages, for minority and female participation for each construction craft can be found on ODOT's website at <http://www.dot.state.oh.us/Divisions/ContractAdmin/Contracts/Pages/default.aspx>. These goals are based on 2000 census data and represent the area, per craft, minority and female availability pool.

Minority and female utilization obligations by craft per county (applicable to project):

<http://www.dot.state.oh.us/Divisions/ContractAdmin/Contracts/Construction/CountyAvailability-ByTrade.pdf>

Statewide utilization obligations by craft (applicable to the Contractor's statewide workforce):
<http://www.dot.state.oh.us/Divisions/ContractAdmin/Contracts/Construction/StatewideAverages-ByTrade.pdf>

Effective 11/21/2011 the New Hire Definition will be as follows:

An individual who has a break in service (not on an employer's payroll) for a period of 12 months or longer and the person affected is not a salaried employee but belongs to a union craft. Individuals compensated for training or incidental work which does not cause a break in unemployment compensation, i.e., paid by voucher check or petty cash, are considered new hires if the individual's break in service is 12 months or longer.

The time frame for a new hire shall be associated with the first project worked for that contractor regardless of whether it is public or private. When reporting new hires, the contractor shall identify that employee as a new hire on that specific project only. Subsequent work, barring a break in service of 12 months or more, would not qualify the employee as a new hire for that contractor.

The Contractor's compliance shall be based on the implementation of affirmative action obligations required by the specifications set forth in 23 CFR Part 230, and its good faith efforts to meet these obligations. The hours of minority and female employment and training must be substantially uniform throughout the length of the contract, and in each trade, and the Contractor shall make a good faith effort to employ minorities and females on each of its projects. The transfer of minority or female employees or trainees from Contractor to Contractor or from project to project for the sole purpose of meeting the affirmative action obligations shall be a violation of the contract and regulations in 23 CFR Part 230. The good faith efforts put forth by the contractor will be measured against the total work hours performed. Under FHWA, ODOT is the authority tasked with ensuring that the contractor adheres to the aforementioned regulations. In addition to complying with the Required Contract Provisions as outlined in the attached subcontract agreement the Contractor shall provide immediate written notification to the ODOT and the Prime Contractor when referral practices of the union or unions with which the Contractor has a collective bargaining agreement impede the company's efforts to meet its equal opportunity obligations.

The Office of Federal Contract Compliance Programs (OFCCP) administers and enforces equal employment opportunity laws that apply to Federal government contractors and subcontractors supplying goods and services, including construction, to the Federal Government under 41 CFR Part 60, Executive Order 11246, Section 503, and the affirmative action provisions of VEVRAA. The OFCCP monitors compliance with these laws primarily through compliance evaluations, during which a compliance officer examines the contractor's affirmative action efforts and employment practices. Under Executive Order 11246, the OFCCP may perform contract compliance reviews on contractors involved with federally funded ODOT projects.

Requirements for affirmative action obligations governing OFCCP contract compliance reviews are those listed in the Federal Register for the Economic Area.

https://www.dol.gov/ofccp/TAGuides/new_contractors_guide.htm page E-32

The Department of Administrative Services (DAS), Equal Opportunity Division, is responsible for ensuring state contractors implement and adhere to the State of Ohio's affirmative action program pursuant to Ohio Administrative Code (OAC) 123:2-3-02. Specifically, this unit's responsibilities include the issuance of certificates of compliance under ORC 9.47 and 153.08, conducting project site visits and compliance reviews (desk audits) to ensure contractors utilize minorities and women in the construction trades, as well as maintaining a working environment free of discrimination, harassment and intimidation. The DAS may perform contract compliance reviews on contractors involved with state funded ODOT projects. Requirements for affirmative action obligations governing DAS contract compliance reviews are those

listed in the O.A.C. for the Metropolitan Statistical Area in which a project is located. <http://das.ohio.gov/Divisions/EqualOpportunity/ConstructionCompliance.aspx>

All prime and subcontractors regardless on the number of employees or the state contract amount are required to submit monthly utilization reports (Input Form 29) to Ohio Department of Administrative Services covering the contractor's total workforce within the state of Ohio. The reports must be filed electronically by the 10th of each month, beginning with the contract award and continuing until the contractor or subcontractor completes performance of the state contract. <http://das.ohio.gov/Divisions/EqualOpportunity/InputForm29.aspx>

The Contractor shall provide written notification to the Director of the Office of Federal Contract Compliance Programs, 200 N. High Street, Room 409, Columbus, Ohio 43215, within 10 working days of award of any construction subcontract in excess of \$10,000 at any tier for construction work under the contract resulting from this solicitation. The notification shall list the name, address and telephone number of the subcontractor, employer identification number of the subcontractor, estimated dollar amount of the subcontract, estimated starting and completion dates of the subcontract and the geographical area in which the subcontract is to be performed.

12. PN 029 - 10/15/2004 - ON-THE JOB TRAINING (OJT) PILOT PROGRAM

The requirements of this Training Special Provision supersede subparagraph 7b of the Special Provision entitled Special Employment Opportunity Responsibilities and implements 23 U.S.C. 140(a).

The following must be included as part of the Contractor's equal employment opportunity affirmative action training program:

The Contractor must provide on-the-job training aimed at developing full journey persons in the type or job classification in which they work.

The contractor is not required to have a specific number of trainees assigned to this project. The number of trainees will be distributed among the work classifications on the basis of the Contractor's needs and the availability of the journey persons in the various classifications. The Contractor will be credited for each trainee employed by him or her who is currently enrolled or becomes enrolled in an approved program.

Training and upgrading of minorities and women toward journey person status is a primary objective of this Training Special Provision. Accordingly, the Contractor must make every effort to enroll minority trainees and women (e.g., by conducting systematic and direct recruitment through public and private sources likely to yield minority and women trainees) to the extent that such persons are available within a reasonable area of recruitment. This training commitment is not intended, and will not be used, to discriminate against any applicant for training, regardless of whether the applicant is a member of a minority group or not.

No employee will be employed as a trainee in any classification in which he or she has successfully completed a training course leading to journey person status or in which he or she has been employed as a journey person. The Contractor must satisfy this requirement by including appropriate questions in the employee's application or by other suitable means. Regardless of the method used, the Contractor's records must document the findings in each case.

The minimum length and type of training for each classification will be established in the training program selected by the Contractor.

No payment by the LPA will be made to the Contractor for providing this training. However, if the Contractor fails to provide adequate training and cannot show good faith efforts on its part to provide

adequate training, it will be subject to a formal compliance review to determine the Contractor's efforts in meeting the EEO laws and regulations.

The Contractor must provide the following reports:

1. CR1 Report
 - A. To be completed on each trainee
 - B. To be filled out at the start of training and finish of training or at the end of the year, whichever comes first
 - C. To be submitted to the ODOT District in which the Contractor's home office is located.
2. Tracking will be on an annual basis. The Contractor must submit the subsequent CR1 to the ODOT District in which the Contractors home office is located.

The prime or subcontractor conducting the training must be involved in at least one Federal project per calendar year in order to get FHWA training credit. Participation in the OJT Program is not project or contract specific.

All Contractors are encouraged to participate in the OJT program. Such a program will be considered when examining the contractor's Good Faith Efforts toward meeting its contractual affirmative action obligations.

All Contractors shall submit their own Training Program or Apprenticeship Certificate, for approval, to the ODOT District in which the company's home office is located.

All OJT Trainees must have the appropriate certification. Apprenticeship Certificates can be obtained from the State of Ohio, Bureau of Apprenticeship and Training. The union apprenticeship agreement is not acceptable verification of an apprentice's enrollment in a union sponsored training program. A copy of the Apprenticeship Certificate along with a statement indicating the number of months/years the employee has been in the apprenticeship program must be submitted to the ODOT EEO Coordinator in the company's home district and to the prevailing wage coordinator in the district responsible for the project within 90 days of the apprentice beginning work on the project.

13. PN 059 - 10/15/2004 - WAGE DETERMINATION APPEALS PROCESS

- 1.) Has there been an initial decision in the matter? This can be:
 - * An existing published wage determination
 - * A survey underlying a wage determination
 - * A Wage and Hour Division letter setting forth a position on a wage determination matter
 - * A conformance (additional classification and rate) ruling

On survey related matters, initial contact, including requests for summaries of surveys, should be with the Wage and Hour Regional Office for the area in which the survey was conducted because those Regional Offices have responsibility for the Davis-Bacon survey program. If the response for this initial contact is not satisfactory, then the process described in 2.) and 3.) should be followed.

With regard to any other matter not yet ripe for the formal process described here, initial contact should be with the Branch of Construction Wage Determinations. Write to:

Branch of Construction Wage Determination
Wage and Hour Division
U. S. Department of Labor
200 Constitution Avenue, N.W.
Washington, D. C. 20210

- 2.) If the answer to the question in 1.) is yes, then an interested party (those affected by the action) can request review and reconsideration from the Wage and Hour Administrator (see 29 CFR Part 1.8 and 29 CFR Part 7). Write to:

Wage and Hour Administrator
U. S Department of Labor
200 Constitution Avenue, N.W.
Washington, D. C. 20210

The request should be accompanied by a full statement of the interested party's position and by any information (wage payment data, project description, area practice material, etc.) that the requester considers relevant to the issue.

- 3.) If the decision of the Administrator is not favorable, an interested party may appeal directly to the Administrative Review Board (formerly the Wage Appeals Board). Write to:

Administrative Review Board
U. S. Department of Labor
200 Constitution Avenue, N. W.
Washington, D. C. 20210

- 4.) All decisions by the Administrative Review Board are final.

14. PN 061 –10/22/2012- WAGE SCALE ON ALL FEDERAL-AID PROJECTS

The wage rates for this project were determined by the Secretary of Labor in accordance with Federal-Aid requirements. LPA must formally incorporate into contract documents.

Contractors shall use only the classifications and wage rates set forth in the United States Department of Labor (USDOL) wage decision found at website noted below on payrolls submitted to the District Office. Additionally, please note that the wage modification in effect at the time of the project sale date, shall be used by all contractors.

This USDOL wage decision may be viewed, by accessing the United States Department of Labor (USDOL) website at:

<http://www.wdol.gov/>

This contract requires the payment of the total of the basic hourly rates plus the fringe benefits payments for each classification in accordance with the following regulations which by reference are made part of this contract:

- 1) The U.S. Department of Labor Regulations, Title 29, Subtitle A, Part 5, Sections 5.5, 5.31, and 5.32, most recent revision at contract execution.
- 2) Form FHWA-1273 (most recent revision at contract execution) Part IV. Payment of Predetermined Minimum Wage and Part V. Statements and Payrolls.

The failure to pay prevailing wages to all laborers and mechanics employed on this project, shall be considered a breach of contract. Such a failure may result in the termination of the contract and debarment.

The Contractor and all subcontractors shall pay all wages and fringe benefits by company check. All payroll records and canceled pay checks shall be maintained for at least three years after final acceptance as defined in section 109.12 of the Ohio Department of Transportation Construction and Materials Specifications. The Contractor's and all subcontractor's payroll records and canceled pay checks shall be made available for inspection by the Department and the U.S. Department of Labor, upon request, anytime

during the life of the contract, and for three years thereafter by the U.S. Department of Labor. Additionally, the Contractor and all subcontractors shall permit such representatives to interview any employees during working hours while the employee is on the job.

The wage and fringe rates determined for this project shall be posted by the Contractor in a prominent and accessible place on the project, field office, or equipment yard where they can be easily read by the workers.

The Contractor and all subcontractors shall submit to the District Construction Office, certified payrolls each week beginning three weeks after the start of work. These payrolls shall be on a Form WH-347 or equivalent and shall show the following:

- 1) Employee name, address, classification, and hours worked.
- 2) The basic hourly and overtime rate paid, total pay, and the manner in which fringe benefit payments have been irrevocably made.
- 3) The project number and pay week dates.
- 4) Original signature of a company officer on the certification statement.

Additionally, a copy of the "Apprentice Certification" obtained from the Ohio State Apprenticeship Council, must accompany all certified payrolls submitted for all apprentices working on this project.

Please be aware that it is ultimately the responsibility of the Contractor to ensure that all laws relating to prevailing wages in the USDOL Regulations, Title 29, parts 1 and 5, are strictly adhered to by all subcontractors on the project.

If the Contractor or any subcontractor fails to comply with any of the provisions contained in this proposal note, the Department may terminate the contract, debar the Contractor or Subcontractor and/or withhold or suspend pay estimates after written notice and a reasonable opportunity to comply has been provided.

The applicable wage and fringe rates for this project are to be incorporated in their entirety as an attachment to the executed contract.

15. LIMITATION ON USE OF CONTRACT FUNDS FOR LOBBYING

1. The prospective bidder certifies, by signing and submitting this bid proposal, to the best of his or her knowledge and belief, that:
 - (a.) No Federal appropriated funds have been paid or will be paid, by or on behalf of the undersigned, to any person for influencing or attempting to influence an officer or employee of any Federal agency, a Member of Congress, an officer or employee of Congress, or an employee of a member of Congress in connection with the awarding of any Federal contract, the making of any Federal grant, the making of any Federal loan, the entering into of any cooperative agreement, and the extension, continuation, renewal, amendment, or modification of any Federal contract, grant, loan, or cooperative agreement.
 - (b.) If any funds other than Federal appropriated funds have been paid or will be paid to any person for influencing or attempting to influence an officer or employee of any Federal agency, a Member of Congress, an officer or employee of Congress, or an employee of a Member of Congress in connection with this Federal contract, grant, loan, or cooperative agreement, the undersigned shall complete and submit Standard Form-LLL, "Disclosure Form to Report Lobbying" in accordance with its instructions.
2. This certification is a material representation of fact upon which reliance was placed when this transaction was made or entered into. This certification is a prerequisite for making or entering into this transaction imposed by Section 1352, Title 31, U.S. Code. Any person who fails to file

the required certification shall be subject to civil penalty of not less than \$10,000 and not more than \$100,000 for each such failure.

3. The prospective bidder also agrees by submitting his or her bid proposal that he or she shall require that the language of this certification be included in all lower tier subcontracts, which exceed \$100,000 and that all such subrecipients shall certify and disclose accordingly.

16. PN 045 - 10/15/2004 - NON -COLLUSION AFFIDAVIT

In accordance with Title 23 United States Code, Section 112 and Ohio Revised Code, Chapter 1331 et. seq: and Sections 2921.11 and 2921.13, the bidder hereby states, under penalty of perjury and under other such penalties as the law provides, that he or his agents or employees have not entered either directly or indirectly into any agreement, participated in any collusion, or otherwise taken any action in restraint of free competitive bidding in connection with this proposal. Execution of this proposal on the signature portion thereof shall constitute also signature of this Non-Collusion Affidavit as permitted by title 28 United States Code, Section 1746.

REPORTING BID RIGGING

To report bid rigging activities call:

1-800-424-9071

The U.S. Department of Transportation (DOT) operates the above toll-free "hotline" Monday through Friday, 8:00 a.m. to 5:00 p.m. eastern time. Anyone with knowledge of possible bid rigging, bidder collusion, or other fraudulent activities should use the "hotline" to report such activities.

The "hotline" is part of the DOT's continuing effort to identify and investigate highway construction contract fraud and abuse and is operated under the direction of the DOT Inspector General. All information will be treated confidentially, and caller anonymity will be respected.

17. PN 014 - 10/15/2004 - DRUG-FREE WORKPLACE

The prime contractor agrees to comply with all applicable state and federal laws regarding drug-free workplace. The prime contractor shall make a good faith effort to ensure that all its employees, while working on this project, will not purchase, transfer, use or possess illegal drugs or alcohol or abuse prescription drugs in any way.

The prime contractor shall also require that this contractual obligation be placed in all subcontractor and materialman contracts that it enters into and further requires that all subcontractors and materialmen place the same contractual obligations in each of their lower tier contracts.

18. PN 034 - 05/25/2011 – DRUG FREE SAFETY PROGRAM

During the life of this project, the Contractor and all its Subcontractors, that provide labor on the Project site, must be enrolled in and remain in good standing in the Ohio Bureau of Worker's Compensation ("OBWC") Drug-Free Safety Program ("DFSP") or a comparable program approved by the OBWC.

In addition to being enrolled in and in good standing in an OBWC-approved DFSP or a comparable Drug Free Workplace Program ("DFWP") approved by the OBWC, the LPA requires each Contractor and Subcontractor that provides labor, to subject its employees who perform labor on the project site to random drug testing of 5 percent of its employees. The random drug testing percentage must also include the on-site supervisors of the Contractors and Subcontractors. Upon request, the Contractor and Subcontractor shall provide evidence of required testing to the LPA.

Each Subcontractor shall require all lower-tier Subcontractors that provides labor on the project site with whom the Subcontractor is in contract for the Work to be enrolled in and be in good standing in the OBWC DFSP or an OBWC-approved DFWP prior to a lower-tier Subcontractor providing labor at the Site.

The LPA will declare a bid non-responsive and ineligible for award if the Contractor is not enrolled and in good standing in the Ohio Bureau of Workers' Compensation's DFSP Discount Program or a similar program approved by the Bureau of Workers' Compensation within 8 days of the bid opening. Furthermore, the LPA will deny all requests to sublet when the subcontractor does not comply with the provisions of this proposal note.

Failure of the Contractor to require a Subcontractor to be enrolled in and be in good standing in the OBWC DFSP or an OBWC-approved DFWP prior to the time that the Subcontractor provides labor at the Site, shall result in the Contractor being found in breach of the Contract and that breach shall be used in the responsibility analysis of that Contractor or the Subcontractor who was not enrolled in a program for future contracts with the State for five years after the date of the breach.

19. OHIO WORKERS' COMPENSATION COVERAGE

The Contractor must secure and maintain valid Ohio workers' compensation coverage until the project has been finally accepted by the Ohio Department of Transportation. A certificate of coverage evidencing valid workers' compensation coverage must be submitted to the LPA before the contract will be executed by the LPA.

The Contractor must immediately notify the LPA, in writing, if it or any subcontractor fails or refuses to renew their workers' compensation coverage. Furthermore, the Contractor must notify the LPA, in writing, if its or any of its subcontractor's workers' compensation policies are canceled, terminated or lapse.

The failure to maintain valid workers' compensation coverage shall be considered a breach of contract which may result in the Contractor or subcontractor being removed from the project, withholding of pay estimates and/or termination of the contract.

20. PN 038 - 10/15/2004 - UNRESOLVED FINDING FOR RECOVERY

The Contractor affirmatively represents to the LPA that it is not subject to a finding for recovery under Ohio Revised Code §9.24, or that it has taken the appropriate remedial steps required under §9.24 or otherwise qualifies under that section. The Contractor agrees that if this representation is deemed to be false, the contract shall be void ab initio as between the parties to this contract, and any funds paid by the state hereunder shall be immediately repaid to the LPA, or an action for recovery may be immediately commenced by the LPA and/or for recovery of said funds.

21. PN 039 - 10/15/2004 - ASSIGNMENT OF ANTITRUST CLAIMS IN STATE CONTRACT LANGUAGE

The Contractor should recognize that in actual economic practice, overcharges resulting from antitrust violations are usually borne by ODOT and/or the LPA. As consideration for the Award of the Contract and intent to be legally bound, the Contractor acting herein by and through the person signing this contract on behalf of the Contractor as a duly authorized agent, hereby assigns, sells, conveys, and transfers to ODOT and/or the LPA any and all right, title and interest to any and all claims and causes of action the Contractor now has or hereafter requires under state or federal antitrust laws provided that the claims or causes of action related to the goods or services that are the subject to the contract. In addition, the Contractor warrants and represents that it will require any and all of its subcontractors and first tier suppliers to assign any and all federal and state antitrust claims and causes of action to ODOT and/or the LPA. The provisions of this article shall become effective at the time the LPA executes this contract without further acknowledgment by any of the parties.

All contracting entities shall assign their rights and responsibilities to ODOT and/or the LPA for all antitrust claims and causes of action regarding subcontractors.

22. PN 024 – 04/21/2006 – US ARMY CORPS OF ENGINEERS AND OHIO ENVIRONMENTAL PROTECTION AGENCY PERMITS

The above referenced permits are incorporated and made a part of this contract as special provisions incorporated herein. Therefore, in the event that the Contractor or its agents refuse or fail to adhere to the requirements of the US Army Corps of Engineers 404 Permit, and/or the Ohio Environmental Protection Agency's 401 Water Quality Certification and an assessment or fine, is made or levied against the Ohio Department of Transportation, the Contractor shall reimburse the Department within thirty (30) calendar days of the notice of assessment or fine or the Department may withhold the amount of the fine from the Contractor's next pay estimate. All money collected or withheld from the Contractor shall be delivered to the permitting agencies issuing the assessment or fine.

These fines are not to be construed as a penalty but are liquidated damages to recover costs assessed against the Department due to the Contractor's refusal or failure to comply with the permits.

23. PN 007 – 07/19/2019 - DBE TRUCKING

The Code of Federal Regulations Title 49, Section 26.55(d)(4)(5)(6) governs trucking operations.

The DBE trucking firm must be able to quote and negotiate its own prices. The DBE trucking firm must also provide a quote for each project that the firm is to be utilized toward the project DBE goal.

The DBE will be responsible for the management and supervision of their trucking operation on each contract. A DBE is not performing a CUF if the contract exists for the purpose of creating the appearance of DBE participation.

The DBE must own and operate at least one fully licensed, insured, and operational truck used on the contract.

The DBE receives credit for the total value of the transportation services the DBE provides on the contract using trucks the DBE owns, insures, and operates using drivers it employs (not 1099/independent contractors).

The Disadvantaged Business Enterprise (DBE) may lease trucks on a long-term basis (a year or more), and receive full DBE credit as long as employees of the DBE operate the truck.

A lease must indicate that the DBE has exclusive use of and control over the truck, including responsibility of maintenance and insurance. This does not preclude the leased truck from working for others during the term of the lease with the DBEs consent, as long as the lease gives the DBE absolute priority for use of the leased truck. Leased trucks must display the DBEs name and identification number as well.

The DBE must carry a copy of the lease agreement in the leased truck when working onsite.

Credit for expenditures with DBEs for materials or supplies toward the DBE goal is described as follows:

1. A DBE firm may be a regular dealer in bulk items such as petroleum products, steel, cement, gravel, stone, or asphalt without owning, operating, or maintaining a place of business if the firm both owns and operates distribution equipment for the products. Any supplementing of a regular dealer's own distribution equipment shall be by a long-term lease agreement and not on an *ad hoc* or contract-by-contract basis.

2. When the materials or supplies are obtained from a DBE MSV (Materials and Supplies Vendor) manufacturer the prime contractor may receive credit for 100 percent of the cost of the materials or supplies toward the DBE goal. For purposes of this section, a manufacturer is a firm that operates or maintains a factory or establishment that produces, on the premises, the materials, supplies, articles, or equipment required under the contract and of the general character described by the specifications.
3. When the materials or supplies are purchased from a DBE MSV regular dealer or supplier the prime contractor may receive credit for up to 60 percent of the cost of the materials or supplies toward the DBE goal. For purposes of this section, a regular dealer or supplier is a firm that owns, operates, or maintains a store, warehouse, or other establishment in which the materials, supplies, articles or equipment of the general character described by the specifications and required under the contract are bought, kept in stock, and regularly sold or leased to the public in the usual course of business.

In the past, 60% of the cost of materials and supplies purchased from a DBE MSV (100% from a DBE MSV manufacturer) would usually be counted toward DBE goals. **Effective September 1, 2018:**

- o Prime contractors must obtain information about the method of procurement for each item to be procured from a DBE MSV. The DBE Affirmation Form has been modified to accommodate this information.
- o To be eligible to receive **100% credit** toward DBE goals for a materials and supplies subcontract:
 - The DBE MSV must be certified with the correct (**manufacturer**) NAICS code for the item
 - The DBE MSV must be certified with the correct descriptor for the item
 - The role the DBE MSV will play on the specific procurement in question must be consistent with the **manufacture** of the item, as indicated by the information provided by the DBE MSV
- o To be eligible to receive **60% credit** toward DBE goals for a materials and supplies subcontract:
 - The DBE MSV must be certified with the correct (**wholesale or retail**) NAICS code for the item
 - The DBE MSV must be certified with the correct descriptor for the item
 - The role the DBE MSV will play on the specific procurement in question must be consistent with the **regular sale or lease** of the item, as indicated by the information provided by the DBE MSV
 - **The item must not be drop-shipped**
- o The above scenario applies to both bulk items (petroleum products, steel, cement, gravel, stone, asphalt, and others that ODOT may consider to be bulk items) and non-bulk items. For bulk items, there is an additional scenario whereby a contract with a DBE MSV could receive 60% credit. To be eligible to receive **60% credit** toward DBE goals for a bulk item materials and supplies subcontract:
 - The DBE MSV must be certified with the correct (**wholesale or retail and trucking**) NAICS codes for the item
 - The DBE MSV must be certified with the correct descriptor for the item
 - The role the DBE MSV will play on the specific procurement in question must be consistent with the **regular sale or lease** of the item, as indicated by the information provided by the DBE MSV
 - The DBE MSV must deliver the bulk item from a non-DBE vendor to the prime

contractor using distribution equipment that it both owns (or for which it has a long-term (1 year or more) lease) and operates with its regular (not ad hoc) employees.

- o If not eligible for 100% or 60% credit, an item may still be eligible for credit toward DBE goals, but only for the **fee or commission the DBE MSV receives for its services**, and only if the following additional criteria are met:
 - The DBE MSV must be certified with NAICS code 425120 Wholesale Trade Agents and Brokers
 - The DBE MSV must convincingly explain how the prime contractor benefits by transacting business with it rather than directly with the non-DBE vendor from which the DBE MSV is re-selling.
- The usual good faith efforts process applies.
- All credit toward DBE goals is conditional. Actual credit will be determined based upon invoices, receipts, and/or transportation documents/bills of lading, which must be submitted to ODOT as they are received throughout the course of the project.

DBE MSV DIRECTORY - <http://www.dot.state.oh.us/Divisions/ODI/SDBE/Pages/DBE-Directory.aspx> (select MSV only)

DBE AFFIRMATION FORM - The new DBE Affirmation Form is now available at <http://www.dot.state.oh.us/Divisions/ODI/SDBE/Pages/Resources.aspx>.

24. **PN 013 – 03/15/2019 - DISADVANTAGED BUSINESS ENTERPRISE (DBE) UTILIZATION PLAN AND GOOD FAITH EFFORTS**

Please see optional Appendix A - "Checklist for Bidders – Federally Funded Projects with a DBE Goal", to ensure compliance with the requirements outlined in PN 013.

DBE UTILIZATION PLAN

All Bidders shall submit a DBE Utilization Plan at the time of bid setting forth specific information demonstrating how the Bidder will achieve the DBE goal. By submitting a DBE Utilization Plan, the Bidder is affirming that they will be using the DBE firms identified in the Utilization Plan to meet the DBE contract goal. The DBE Utilization Plan shall be submitted with Formstack at time of bid submission. Any bids received without electronic submission of the DBE Utilization Plan at or before bid time, will be deemed unresponsive. **Bidders shall submit their DBE Utilization Plans via: https://odot.formstack.com/forms/dbe_copy.** This file contains the current list of certified DBEs and is updated regularly. The DBE Utilization Plan must be filled out completely and submitted prior to bid opening.

The DBE Utilization Plan shall include the following information:

- 1) The names and addresses of the certified DBE firm(s) that will be used to meet the DBE goal;
- 2) A description of the work that each DBE will perform. To count toward meeting a goal, each DBE firm must be certified in a NAICS code applicable to the kind of work the firm would perform on the contract;
- 3) Whether the DBE firm(s) being used to meet the goal will be utilized as a subcontractor, regular dealer, manufacturer, consultant or other capacity; and
- 4) The dollar amount of the participation of each DBE firm used to meet the DBE goal.

PROJECTS AWARDED ON ALTERNATES

In the event the project is awarded on alternates which increases or decreases the total dollar amount of the bid, a revision to the DBE Utilization Plan and DBE Affirmation Form(s) shall be submitted and approved by the Office of Small & Disadvantaged Business Enterprise within five (5) calendar days after the notification of the alternates.

DBE AFFIRMATION

The Apparent Low Bidder shall ensure the DBE firms being utilized to meet the DBE goal affirm their participation in the bid within five (5) calendar days after the bid opening to ODOT. The contract dollar amount(s) and/or DBE firm(s) included in the Apparent Low Bidder's DBE Utilization Plan must match the contract dollar amount(s) and/or DBE firm(s) included on the DBE Affirmation Form(s). If the contract dollar amount(s) and/or DBE firm(s) do not match, the Apparent Low Bidder shall utilize the Request to Terminate/Substitute DBE Form located at

<http://Transportation.ohio.gov/Divisions/ODI/SDBE/Pages/Resources.aspx> and submit for review and approval by the Office of Small & Disadvantaged Business Enterprise within five (5) calendar days of the bid opening.

The Apparent Low Bidder shall utilize the DBE Affirmation Form located at

<http://Transportation.ohio.gov/Divisions/ODI/SDBE/Pages/Resources.aspx>. The DBE Affirmation Form will be utilized as written confirmation from each listed DBE firm that it is participating in the contract in the type and amount of work provided in the Bidder's DBE Utilization Plan. The Apparent Low Bidder shall submit a separate DBE Affirmation Form for each DBE it is utilizing for the DBE goal and their Good Faith Efforts package if they were not able to attain the DBE Goal via DBE participation.

All other Bidders shall submit a DBE Affirmation Form(s) if notified that the information is required in order for ODOT to complete its assessment. Bidders shall have five (5) calendar days from the date of notification to submit all required DBE Affirmation Forms to ODOT. Notification will be by email.

In the event a DBE firm fails to confirm the information contained in the DBE Affirmation Form within five (5) calendar days of bid opening, the Apparent Low Bidder shall submit a Request to Terminate/Substitute DBE Form, as set forth herein. The Request to Terminate/Substitute DBE Form shall be submitted within five (5) calendar days after bid opening in order for the Apparent Low Bidder to still be considered for contract award. The Apparent Low Bidder shall include as its reason for termination the DBE firm's failure to provide a timely affirmation and should include all efforts the Apparent Low Bidder made to obtain the affirmation from the DBE firm and shall attach proof of these efforts, if available. If the Apparent Low Bidder intends to replace the DBE Firm, it shall include the replacement firm's information on the form. In the event the Apparent Low Bidder is unable to affirm a DBE firm included in its original DBE Utilization Plan at bid submission and it results in a goal shortfall, Good Faith Efforts (GFE's) must be submitted by the fifth calendar day after bid opening. All GFE documentation submitted for consideration should demonstrate the efforts the Bidder made prior to the time of bid submission to secure sufficient DBE participation on the project to meet the DBE goal although the Bidder was unable to do so. A DBE firm's failure to timely confirm information contained in the DBE Affirmation Form will be considered as good cause to terminate the DBE firm and will also be considered a part of the Apparent Low Bidder's Good Faith Efforts in meeting the goal.

DBE BIDDERS

In the event that the Bidder is also a certified DBE firm, the Bidder is required to complete a DBE Utilization Plan as set forth above. In this instance, however, the certified DBE Bidder would not need to submit a DBE Affirmation Form for the work it is planning to self-perform in order to meet the goal. ODOT will consider the submission of the bid as the certified DBE Bidder's written confirmation that it is participating in the contract.

However, a DBE Affirmation Form must be submitted for all other DBE firms that are being utilized toward the DBE goal.

JOINT VENTURES

In the event that the Bidder is a Joint Venture, the Joint Venture will only be considered a Certified DBE firm if the Joint Venture itself has been certified. The Joint Venture may, however, utilize a Certified DBE firm that is also a partner in the Joint Venture as part of its DBE Utilization Plan. The Certified DBE Firm/Joint Venture Partner, however, does not need to submit a DBE Affirmation Form for any work that the Certified DBE Firm/Joint Venture Partner is going to perform to meet the goal. ODOT will consider submission of the Joint Venture's bid as the Certified DBE Firm/Joint Venture Partner's confirmation that it is participating in the contract.

GOOD FAITH EFFORTS (GFE's)

In the event that the DBE contract goal established by ODOT is not met, the Apparent Low Bidder shall demonstrate that it made adequate good faith efforts to meet the goal, even though it did not succeed in obtaining enough DBE participation to do so.

If the Apparent Low Bidder does not meet the goal at bid time, the Apparent Low Bidder shall submit its Good Faith Efforts (GFE's) documentation within five (5) calendar days of the bid opening. Submission of DBE affirmation(s) with additional participation sufficient to meet the DBE contract goal does not cure the Apparent Low Bidder's failure to meet the goal at bid time or eliminate the Apparent Low Bidder's responsibility of submitting GFE's within five (5) calendar days of the bid opening.

The Apparent Low Bidder shall demonstrate its GFE's by submitting the following information within five (5) calendar days after the bid opening:

- (1) All written quotes received from certified DBE firms;
- (2) All written (including email) communications between the Apparent Low Bidder and DBE firms;
- (3) All written solicitations to DBE firms, even if unsuccessful;
- (4) Copies of each non-DBE quote when a non-DBE was selected over a DBE for work on the contract;
- (5) Phone logs of communications with DBE firms.

The Apparent Low Bidder shall utilize the Pre-Bid GFE Template to document their GFE's. This template and supporting documentation shall be sent along with any DBE Affirmation Forms within five (5) calendar days of bid opening. ODOT has provided Good Faith Efforts Guidance located at <http://Transportation.ohio.gov/Divisions/ODI/SDBE/Pages/Resources.aspx>.

All other Bidders shall submit documentation of GFE's if notified that the information is required in order for ODOT to complete its bid assessment. Bidders shall have five (5) calendar days from the date of notification to submit all required GFE documentation. Notification will be by phone or email.

ODOT shall utilize the guidance set forth in 49 CFR §26.53 Appendix A in determining whether the Bidder has made adequate good faith efforts to meet the goal.

ADMINISTRATIVE RECONSIDERATION

ODOT will review the GFE documentation and issue a written determination on whether adequate GFE's have been demonstrated prior to contract award. If ODOT determines that the Apparent Low Bidder has failed to demonstrate adequate GFE's to meet the goal, the Apparent Low Bidder will have an opportunity for administrative reconsideration prior to the contract being awarded.

As part of this reconsideration, the Apparent Low Bidder may provide written documentation or argument concerning the issue of whether it met the goal or made adequate good faith efforts to do so. Such written documentation or argument must be provided to ODOT, attention to the Office of Chief Legal Counsel, 1980

West Broad Street, MS 1500, Columbus, Ohio 43223 (with copy to the Office of Contract Sales, MS 4110), within two (2) business days of ODOT's written determination that GFE's were not adequately demonstrated. The Apparent Low Bidder may also include in their written documentation a request for an in-person meeting to discuss the issue of whether it met the goal or made adequate good faith efforts to do so. ODOT's Office of Chief Legal Counsel will respond to the Apparent Low Bidder within five (5) business days of receiving written documentation or holding the in-person meeting.

ODOT will send the Apparent Low Bidder a written decision on reconsideration explaining the basis for finding that the Apparent Low Bidder did or did not meet the goal or make adequate good faith efforts to do so. The result of the reconsideration process is not administratively appealable to the United States Department of Transportation.

TERMINATION OR REPLACEMENT OF A DBE

By submitting a DBE Utilization Plan, the Bidder is committing to use the DBE firms identified in the plan. The Apparent Low Bidder/Awarded Contractor shall utilize the specific DBEs listed in the DBE Utilization Plan to perform the work and supply the materials for which each is listed unless the Apparent Low Bidder/Awarded Contractor obtains written consent as provided in this paragraph. In order to request termination or substitution of a DBE firm, the Apparent Low Bidder/Awarded Contractor shall utilize the Request to Terminate/Substitute DBE Form located at <http://Transportation.ohio.gov/Divisions/ODI/SDBE/Pages/Resources.aspx>

This termination/replacement procedure applies only to DBE firms or the amount of work being utilized to meet the goal.

Without ODOT's written consent to terminate/replace a DBE firm being utilized to meet the goal, the Awarded Contractor shall not be entitled to any payment for DBE listed work or material unless it is performed or supplied by the listed DBE.

GOOD CAUSE

ODOT may provide written consent to terminate a DBE only if it agrees, for reasons stated in a concurrence document, that the Apparent Low Bidder/Awarded Contractor has good cause to terminate the DBE firm.

For purposes of this paragraph, good cause to terminate a DBE includes the following circumstances:

- 1) The listed DBE firm fails or refuses to provide the required DBE Affirmation Form or to execute a written contract;
- 2) The listed DBE firm fails or refuses to perform the work of its subcontract in a manner consistent with normal industry standards. Provided, however, that good cause does not exist if the failure or refusal of the DBE firm to perform its work on the subcontract results from the bad faith or discriminatory action of the awarded contractor;
- 3) The listed DBE firm fails or refuses to meet the awarded contractor's reasonable, nondiscriminatory bond requirements.
- 4) The listed DBE firm becomes bankrupt, insolvent, or exhibits credit unworthiness;
- 5) The listed DBE firm is ineligible to work on public works projects because of suspension and debarment proceedings pursuant 2 CFR Parts 180, 215 and 1200 or applicable state law;
- 6) ODOT has determined that the listed DBE firm is not a responsible contractor;
- 7) The listed DBE firm voluntarily withdraws from the project and provides to you written notice of its withdrawal;
- 8) The listed DBE is ineligible to receive DBE credit for the type of work required;
- 9) A DBE owner dies or becomes disabled with the result that the listed DBE contractor is unable to complete its work on the contract; and
- 10) Other documented good cause that ODOT determines compels the termination of the DBE firm. Provided, that good cause does not exist if the awarded contractor seeks to terminate a DBE it relied upon to obtain

the contract so that the awarded contractor can self-perform the work for which the DBE contractor was engaged or so that the awarded contractor can substitute another DBE or non-DBE contractor after contract award.

REPLACEMENT

When a DBE firm is terminated or fails to complete its work on the contract for any reason the Awarded Contractor must make GFEs to find another DBE firm to replace the original DBE. These GFEs shall be directed at finding another DBE to perform at least the same amount of work under the contract as the DBE that was terminated, to the extent needed to meet the contract goal. The GFEs shall be documented by the Awarded Contractor. If ODOT requests documentation under this provision, the Awarded Contractor shall submit the documentation within seven (7) calendar days, which may be extended for an additional seven (7) calendar days if necessary at the request of the contractor, and ODOT shall provide a written determination to the contractor stating whether or not GFEs have been demonstrated.

In addition to post-award terminations, the provisions of this section apply to pre-award deletions and substitutions of DBE firms put forward by Bidders in the DBE Utilization Plan.

ADDITION

In the event additional DBE participation is required for the project, the Awarded Contractor shall utilize the DBE Affirmation Form located at <http://Transportation.ohio.gov/Divisions/ODI/SDBE/Pages/Resources.aspx>. The DBE Affirmation Form will be utilized as written confirmation from each DBE firm that it is participating in the contract in the kind and amount of work on the project.

WRITTEN NOTICE TO DBE

Before transmitting to ODOT its request to terminate and/or substitute a DBE firm, the Apparent Low Bidder/Awarded Contractor must give notice in writing to the DBE firm, with a copy to ODOT, of its intent to request to terminate and/or substitute, and the reason(s) for the request.

The Apparent Low Bidder/Awarded Contractor must give the DBE five (5) calendar days to respond to the notice, advising ODOT and the Apparent Low Bidder/Awarded Contractor of the reasons, if any, why it objects to the proposed termination of its subcontract and why ODOT should not approve the Apparent Low Bidder/Awarded Contractor's action. If required in a particular case as a matter of public necessity (e.g., safety), ODOT may provide a response period shorter than five (5) days.

GOAL ATTAINMENT POST AWARD

The Awarded Contractor shall make available upon request a copy of all DBE subcontracts. The Awarded Contractor shall ensure that all subcontracts or agreements with DBEs require that the subcontract and all lower tier subcontractors be performed in accordance with this Proposal Note.

Approval of a DBE Utilization Plan does not ensure approval of C-92 Requests to Sublet nor does approval of a DBE Utilization Plan indicate that the DBE goal has been met. ODOT will monitor goal attainment throughout the life of the project. It is the responsibility of the Awarded Contractor to advise ODOT of any changes to the DBE Utilization plan throughout the life of the project. The DBE goal of a project is stated as a percentage of the contract. In the event the contract amount increases or decreases, the actual dollar amount of the DBE goal for the project may increase or decrease accordingly.

SANCTIONS AND ADMINISTRATIVE REMEDIES

PRE-BID

Failure by the Apparent Low Bidder to do any of the following shall result in the bid being rejected in accordance with ORC §5525.08:

- 1) Failure to submit a complete DBE Utilization Plan at the time of bid;
- 2) Failure to submit DBE Affirmation Form(s) and/or failure to submit Request to Terminate/Substitute DBE Form(s) as required by this Proposal Note; and
Failure to meet the goal and/or failure to demonstrate GFEs to meet the goal as required by this Proposal Note.

POST-BID

Failure by the Awarded Contractor to carry out the requirements of this Proposal Note, including the submission of adequate good faith efforts to meet the goal for a project, is a material breach of the contract and may result in the issuance of sanctions as follows:

- | | |
|-----------|--|
| 1st Tier: | Letter of Reprimand |
| 2nd Tier: | Damages equivalent to the DBE shortfall |
| 3rd Tier: | If a pattern of paying damages persists or the Contractor has falsified, misrepresented or withheld information, ODOT can pursue other remedies available by law including suspension, revocation, and/or debarment. |

Factors to be considered in issuing sanctions may include, but are not limited to the following:

- the magnitude and the type of offense
- the degree of the Contractor's culpability
- any steps taken to rectify
- the Contractor's record of performance on other projects including, but not limited to:
 - annual DBE participation
 - annual DBE participation on projects without goals
 - the number of complaints ODOT has received regarding the Contractor
 - the number of times the Contractor has been previously sanctioned by ODOT

**25. PN - 031 - 10/15/2004 - AFFIDAVIT OF SUBCONTRACTOR PAYMENT
(Required if DBE goal on the project)**

The Code of Federal Regulations 49, 26.37(b), requires the LPA to monitor and verify that work committed to Disadvantaged Business Enterprise (DBE) firms at contract award is actually performed by the DBE's. Additionally, the LPA is required to report the DBE participation on each project, including all work, materials or service sublets. Therefore, it is the LPA's responsibility to discern whether payments are made to DBE firms. An affidavit is to be completed and signed by the contractor within 15 days of the completion of the project. The affidavit seeks to verify actual payments made to DBE firms on the project. Each DBE firm must verify the actual payment amount.

The blank spaces in the affidavit must be filled in correctly, where indicated. The affidavit must be signed by the prime contractor and subcontractor, or by the subcontractor and DBE sub-contractor, if applicable. By signing the affidavit, the noted firm agrees that the payment amount recorded is true and accurate as of the payment time period.

Completed and signed affidavit shall be mailed to the Ohio Department of Transportation, Office of Contracts, DBE Services section, 1980 West Broad Street, Columbus, Ohio 43223. A color scan of the affidavit may be sent in advance to Central Office, to keep project moving forward. However, the originals will still need to be mailed to Central Office.

26. WAIVER OF CM&S 614.03

ODOT's 2016 Construction and Material Specifications section 614.03, third paragraph, does not apply to any project which is not physically located on the National Highway System (NHS), and/or does not impact NHS traffic in any way.

27. ODOT AS OBLIGEE ON BOND

The contractor shall furnish a performance and payment bond in an amount at least equal to 100 percent of the estimate as security for the faithful performance of its contract. In addition to the project Owner, ODOT shall be named as an obligee.

28. NON-DISCRIMINATION PROVISIONS

1) **Compliance with Regulations:** The CONTRACTOR will comply with the regulations relative to nondiscrimination in Federally-assisted programs of the United States Department of Transportation (hereinafter "U.S. DOT") Title 49, Code of Federal Regulations, Part 21, as they may be amended from time to time, (hereinafter referred to as the "Regulations"), which are herein incorporated by reference and made a part of this contract.

In addition, the CONTRACTOR will comply with the provisions of the Americans with Disabilities Act, Section 504 of the Rehabilitation Act, FHWA Guidance, and any other Federal, State, and/or local laws, rules and/or regulations (hereinafter referred to as "ADA/504").

(2) **Nondiscrimination:** The CONTRACTOR, with regard to the work performed by it during the contract, will not discriminate on the grounds of race, color, national origin, sex, age, or disability, in the selection and retention of subcontractors, including procurements of materials and leases of equipment. The CONTRACTOR will not participate either directly or indirectly in the discrimination prohibited by section 21.5 of the Regulations, including employment practices when the contract covers a program set forth in Appendix B of the Regulations, as well as the ADA/504 regulations.

(3) **Solicitations for Contractors or Subcontractors, including Procurement of Materials and Equipment:** In all solicitations either by competitive bidding or negotiation made by the CONTRACTOR for work to be performed under a contract or subcontract, including procurements of materials or leases of equipment, each potential subcontractor, or supplier will be notified by the CONTRACTOR of the CONTRACTOR's obligations under this contract and the Regulations relative to nondiscrimination on the grounds of race, color, national origin, sex, age, or disability.

(4) **Information and Reports:** The CONTRACTOR will provide all information and reports required by the Regulations or directives issued pursuant thereto, and will permit access to its books, records, accounts, other sources of information, and its facilities as may be determined by the STATE or the Federal Highway Administration (hereinafter "FHWA") to be pertinent to ascertain compliance with such Regulations, orders and instructions. Where any information required of the CONTRACTOR is in the exclusive possession of another who fails or refuses to furnish this information, the CONTRACTOR will

so certify to the STATE or FHWA, as appropriate, and will set forth what efforts it has made to obtain the information.

(5) **Sanctions for Noncompliance:** In the event of the CONTRACTOR's noncompliance with the nondiscrimination provisions of this contract, the LPA will impose such contract sanctions as it or STATE / FHWA may determine to be appropriate, including, but not limited to:

- (a) Withholding of payments to the CONTRACTOR under the contract until the CONTRACTOR complies, and/or
- (b) Cancellation, termination or suspension of the contract, in whole or in part.

(6) **Incorporation of Provisions:** The CONTRACTOR will include the provisions of paragraphs (1) through (5) above in every contract or subcontract, including procurements of materials and leases of equipment, unless exempt by the Regulations, or directives issued pursuant thereto. The CONTRACTOR will take such action with respect to any subcontractor procurement as the LPA or STATE / FHWA may direct as a means of enforcing such provisions including sanctions for noncompliance; provided, however, that, in the event the CONTRACTOR becomes involved in, or is threatened with, litigation with a subcontractor, or supplier as a result of such direction, the CONTRACTOR may request the LPA / STATE to enter into such litigation to protect the interests of the LPA and the STATE, and, in addition, the LPA / STATE may request the United States to enter into such litigation to protect the interests of the United States.

29. PN 095 – 03/30/2020 Potential Impacts and Delays Due to COVID-19

In an effort to anticipate the potential impacts to the Project caused by the COVID-19 threat and in following direction from the Governor and other authorities, the Contractor is on notice of the need to comply with all federal, state and local orders generated to prevent the spread of contagious or infectious diseases, including the Stay at Home Order from the Ohio Director of Health dated March 22, 2020, and subsequent orders, located through the following website:

<https://coronavirus.ohio.gov/wps/portal/gov/covid-19/home/public-health-orders/directors-order-to-stay-at-home>

Contractor is on notice that the Project is considered essential and that the contractor and his employees, subcontractors and suppliers are considered essential businesses and performing essential functions as defined under the Stay at Home Order.

Notwithstanding any other provisions of the contract documents, in the event of project delay or impacts to performance due to a voluntary or mandatory COVID-19 virus Directives, Orders, quarantine or closure directed by government authorities, either party may, by providing notice to the other party as required under CMS 108.02(F), extend the Completion Date for a period of up to thirty (30) days. Extensions under this paragraph shall be considered an excusable, non-compensable delay in accordance with CMS 108.06(B). If any portion of the Work is still not able to be performed upon the expiration of the extension, either party may provide notice to the other party requesting a termination for convenience under 108.09. The termination for convenience remains at the sole discretion of the LPA's Person in Responsible Charge in conjunction with the Office of Local Programs.

The Contractor and LPA will exercise best efforts to utilize remote services to perform Work that otherwise cannot be performed in person due to a voluntary or mandatory COVID19 virus quarantine, closure, or impact as directed by Stay at Home Order.

Impacts to the Project generated by the Stay at Home Order shall not be considered an "issue" under 108.02 (F) for Projects sold after the date of this Note. Contractors are on notice that their bids should include any impacts they foresee or should have reasonably foreseen due to the Stay at Home Order or existing or reasonably foreseeable orders by any other federal, state or local official.

If any emergency order or declaration of any government official is lifted at any time, the LPA will provide written notice to the Contractor that this Note shall be considered void thirty (30) days after receipt of the written notice. If the Stay at Home Order from the Ohio Director of Health dated March 22, 2020 is lifted at any time, this Note shall be considered null and void thirty (30) days after the lifting of those orders.

30. PN 015 – 04/17/2020 - CONTRACT PROVISIONS FOR FEDERAL-AID CONSTRUCTION CONTRACTS

The required contract provisions for federal-aid construction contracts (contained in Form FHWA 1273 revised May 2012 and located here) are hereby incorporated by reference as if rewritten herein. Form FHWA-1273 shall be physically incorporated in all contracts, subcontracts and lower-tier subcontracts (excluding purchase orders, rental agreements and other agreement for supplies or services related to a construction contract). The prime contractor shall be responsible for ensuring that the FHWA-1273 is physically incorporated into all lower-tier subcontracts.

SANCTIONS AND ADMINISTRATIVE REMEDIES

Failure by the prime contractor to include the provisions of FHWA-1273 in their contract or in their lower-tier subcontracts may result in the issuance of sanctions as follows:

1st Tier: Letter of Reprimand

2nd Tier: Damages equivalent to the daily liquidated damages amount found in section 108.07 for each incident of non-compliance

3rd Tier: If a pattern of paying damages persists or the Contractor has falsified, misrepresented or withheld information, the LPA can pursue other remedies available by law including suspension, revocation, and/or debarment.

Factors to be considered in issuing sanctions may include, but are not limited to the following:

- the magnitude and the type of offense;
- the degree of the Contractor’s culpability;
- any steps taken to rectify;
- the Contractor’s record of performance on other projects; and
- the number of times the Contractor has been previously sanctioned by the LPA.

31. REQUIRED CONTRACT PROVISIONS FOR FEDERAL-AID CONSTRUCTION CONTRACTS (Electronic Form FHWA 1273 – May 1, 2012)

- I. General
- II. Nondiscrimination
- III. Nonsegregated Facilities
- IV. Davis-Bacon and Related Act Provisions
- V. Contract Work Hours and Safety Standards Act Provisions
- VI. Subletting or Assigning the Contract
- VII. Safety: Accident Prevention
- VIII. False Statements Concerning Highway Projects
- IX. Implementation of Clean Air Act and Federal Water Pollution Control Act
- X. Compliance with Government wide Suspension and Debarment Requirements
- XI. Certification Regarding Use of Contract Funds for Lobbying

ATTACHMENTS

- A. Employment and Materials Preference for Appalachian Development Highway System or Appalachian Local Access Road Contracts (included in Appalachian contracts only)

I. GENERAL

1. Form FHWA-1273 must be physically incorporated in each construction contract funded under Title 23 (excluding emergency contracts solely intended for debris removal). The contractor (or subcontractor) must insert this form in each subcontract and further require its inclusion in all lower tier subcontracts (excluding purchase orders, rental agreements and other agreements for supplies or services).

The applicable requirements of Form FHWA-1273 are incorporated by reference for work done under any purchase order, rental agreement or agreement for other services. The prime contractor shall be responsible for compliance by any subcontractor, lower-tier subcontractor or service provider.

Form FHWA-1273 must be included in all Federal-aid design-build contracts, in all subcontracts and in lower tier subcontracts (excluding subcontracts for design services, purchase orders, rental agreements and other agreements for supplies or services). The design-builder shall be responsible for compliance by any subcontractor, lower-tier subcontractor or service provider.

Contracting agencies may reference Form FHWA-1273 in bid proposal or request for proposal documents, however, the Form FHWA-1273 must be physically incorporated (not referenced) in all contracts, subcontracts and lower-tier subcontracts (excluding purchase orders, rental agreements and other agreements for supplies or services related to a construction contract).

2. Subject to the applicability criteria noted in the following sections, these contract provisions shall apply to all work performed on the contract by the contractor's own organization and with the assistance of workers under the contractor's immediate superintendence and to all work performed on the contract by piecework, station work, or by subcontract.

3. A breach of any of the stipulations contained in these Required Contract Provisions may be sufficient grounds for withholding of progress payments, withholding of final payment, termination of the contract, suspension / debarment or any other action determined to be appropriate by the contracting agency and FHWA.

4. Selection of Labor: During the performance of this contract, the contractor shall not use convict labor for any purpose within the limits of a construction project on a Federal-aid highway unless it is labor performed by convicts who are on parole, supervised release, or probation. The term Federal-aid highway does not include roadways functionally classified as local roads or rural minor collectors.

II. NONDISCRIMINATION

The provisions of this section related to 23 CFR Part 230 are applicable to all Federal-aid construction contracts and to all related construction subcontracts of \$10,000 or more. The provisions of 23 CFR Part 230 are not applicable to material supply, engineering, or architectural service contracts.

In addition, the contractor and all subcontractors must comply with the following policies: Executive Order 11246, 41 CFR 60, 29 CFR 1625-1627, Title 23 USC Section 140, the Rehabilitation Act of 1973, as amended (29 USC 794), Title VI of the Civil Rights Act of 1964, as amended, and related regulations including 49 CFR Parts 21, 26 and 27; and 23 CFR Parts 200, 230, and 633.

The contractor and all subcontractors must comply with: the requirements of the Equal Opportunity Clause in 41 CFR 60-1.4(b) and, for all construction contracts exceeding \$10,000, the Standard Federal Equal Employment Opportunity Construction Contract Specifications in 41 CFR 60-4.3.

Note: The U.S. Department of Labor has exclusive authority to determine compliance with Executive Order 11246 and the policies of the Secretary of Labor including 41 CFR 60, and 29 CFR 1625-1627. The contracting agency and the FHWA have the authority and the responsibility to ensure compliance with Title 23 USC Section 140, the Rehabilitation Act of 1973, as amended (29 USC 794), and Title VI of the Civil Rights Act of 1964, as amended, and related regulations including 49 CFR Parts 21, 26 and 27; and 23 CFR Parts 200, 230, and 633.

The following provision is adopted from 23 CFR 230, Appendix A, with appropriate revisions to conform to the U.S. Department of Labor (US DOL) and FHWA requirements.

1. Equal Employment Opportunity: Equal employment opportunity (EEO) requirements not to discriminate and to take affirmative action to assure equal opportunity as set forth under laws, executive orders, rules, regulations (28 CFR 35, 29 CFR 1630, 29 CFR 1625-1627, 41 CFR 60 and 49 CFR 27) and orders of the Secretary of Labor as modified by the provisions prescribed herein, and imposed pursuant to 23 U.S.C. 140 shall constitute the EEO and specific affirmative action standards for the contractor's project activities under this contract. The provisions of the Americans with Disabilities Act of 1990 (42 U.S.C. 12101 et seq.) set forth under 28 CFR 35 and 29 CFR 1630 are incorporated by reference in this contract. In the execution of this contract, the contractor agrees to comply with the following minimum specific requirement activities of EEO:

a. The contractor will work with the contracting agency and the Federal Government to ensure that it has made every good faith effort to provide equal opportunity with respect to all of its terms and conditions of employment and in their review of activities under the contract.

b. The contractor will accept as its operating policy the following statement:

"It is the policy of this Company to assure that applicants are employed, and that employees are treated during employment, without regard to their race, religion, sex, color, national origin, age or disability. Such action shall include: employment, upgrading, demotion, or transfer; recruitment or recruitment advertising; layoff or termination; rates of pay or other forms of compensation; and selection for training, including apprenticeship, pre-apprenticeship, and/or on-the-job training."

2. EEO Officer: The contractor will designate and make known to the contracting officers an EEO Officer who will have the responsibility for and must be capable of effectively administering and promoting an active EEO program and who must be assigned adequate authority and responsibility to do so.

3. Dissemination of Policy: All members of the contractor's staff who are authorized to hire, supervise, promote, and discharge employees, or who recommend such action, or who are substantially involved in such action, will be made fully cognizant of, and will implement, the contractor's EEO policy and contractual responsibilities to provide EEO in each grade and classification of employment. To ensure that the above agreement will be met, the following actions will be taken as a minimum:

a. Periodic meetings of supervisory and personnel office employees will be conducted before the start of work and then not less often than once every six months, at which time the contractor's EEO policy and its implementation will be reviewed and explained. The meetings will be conducted by the EEO Officer.

b. All new supervisory or personnel office employees will be given a thorough indoctrination by the EEO Officer, covering all major aspects of the contractor's EEO obligations within thirty days following their reporting for duty with the contractor.

c. All personnel who are engaged in direct recruitment for the project will be instructed by the EEO Officer in the contractor's procedures for locating and hiring minorities and women.

d. Notices and posters setting forth the contractor's EEO policy will be placed in areas readily accessible to employees, applicants for employment and potential employees.

e. The contractor's EEO policy and the procedures to implement such policy will be brought to the attention of employees by means of meetings, employee handbooks, or other appropriate means.

4. Recruitment: When advertising for employees, the contractor will include in all advertisements for employees the notation: "An Equal Opportunity Employer." All such advertisements will be placed in publications having a large circulation among minorities and women in the area from which the project work force would normally be derived.

a. The contractor will, unless precluded by a valid bargaining agreement, conduct systematic and direct recruitment through public and private employee referral sources likely to yield qualified minorities and women. To meet this requirement, the contractor will identify sources of potential minority group employees, and establish with such identified sources procedures whereby minority and women applicants may be referred to the contractor for employment consideration.

b. In the event the contractor has a valid bargaining agreement providing for exclusive hiring hall referrals, the contractor is expected to observe the provisions of that agreement to the extent that the system meets the contractor's compliance with EEO contract provisions. Where implementation of such an agreement has the effect of discriminating against minorities or women, or obligates the contractor to do the same, such implementation violates Federal nondiscrimination provisions.

c. The contractor will encourage its present employees to refer minorities and women as applicants for employment. Information and procedures with regard to referring such applicants will be discussed with employees.

5. Personnel Actions: Wages, working conditions, and employee benefits shall be established and administered, and personnel actions of every type, including hiring, upgrading, promotion, transfer, demotion, layoff, and termination, shall be taken without regard to race, color, religion, sex, national origin, age or disability. The following procedures shall be followed:

a. The contractor will conduct periodic inspections of project sites to insure that working conditions and employee facilities do not indicate discriminatory treatment of project site personnel.

b. The contractor will periodically evaluate the spread of wages paid within each classification to determine any evidence of discriminatory wage practices.

c. The contractor will periodically review selected personnel actions in depth to determine whether there is evidence of discrimination. Where evidence is found, the contractor will promptly take corrective action. If the review indicates that the discrimination may extend beyond the actions reviewed, such corrective action shall include all affected persons.

d. The contractor will promptly investigate all complaints of alleged discrimination made to the contractor in connection with its obligations under this contract, will attempt to resolve such complaints, and will take appropriate corrective action within a reasonable time. If the investigation indicates that the discrimination may affect persons other than the complainant, such corrective action shall include such other persons. Upon completion of each investigation, the contractor will inform every complainant of all of their avenues of appeal.

6. Training and Promotion:

a. The contractor will assist in locating, qualifying, and increasing the skills of minorities and women who are applicants for employment or current employees. Such efforts should be aimed at developing full journey level status employees in the type of trade or job classification involved.

b. Consistent with the contractor's work force requirements and as permissible under Federal and State regulations, the contractor shall make full use of training programs, i.e., apprenticeship, and on-the-job training programs for the geographical area of contract performance. In the event a special provision for training is provided under this contract, this subparagraph will be superseded as indicated in the special provision. The contracting agency may reserve training positions for persons who receive welfare assistance in accordance with 23 U.S.C. 140(a).

c. The contractor will advise employees and applicants for employment of available training programs and entrance requirements for each.

d. The contractor will periodically review the training and promotion potential of employees who are minorities and women and will encourage eligible employees to apply for such training and promotion.

7. Unions: If the contractor relies in whole or in part upon unions as a source of employees, the contractor will use good faith efforts to obtain the cooperation of such unions to increase opportunities for minorities and women. Actions by the contractor, either directly or through a contractor's association acting as agent, will include the procedures set forth below:

a. The contractor will use good faith efforts to develop, in cooperation with the unions, joint training programs aimed toward qualifying more minorities and women for membership in the unions and increasing the skills of

minorities and women so that they may qualify for higher paying employment.

b. The contractor will use good faith efforts to incorporate an EEO clause into each union agreement to the end that such union will be contractually bound to refer applicants without regard to their race, color, religion, sex, national origin, age or disability.

c. The contractor is to obtain information as to the referral practices and policies of the labor union except that to the extent such information is within the exclusive possession of the labor union and such labor union refuses to furnish such information to the contractor, the contractor shall so certify to the contracting agency and shall set forth what efforts have been made to obtain such information.

d. In the event the union is unable to provide the contractor with a reasonable flow of referrals within the time limit set forth in the collective bargaining agreement, the contractor will, through independent recruitment efforts, fill the employment vacancies without regard to race, color, religion, sex, national origin, age or disability; making full efforts to obtain qualified and/or qualifiable minorities and women. The failure of a union to provide sufficient referrals (even though it is obligated to provide exclusive referrals under the terms of a collective bargaining agreement) does not relieve the contractor from the requirements of this paragraph. In the event the union referral practice prevents the contractor from meeting the obligations pursuant to Executive Order 11246, as amended, and these special provisions, such contractor shall immediately notify the contracting agency.

8. Reasonable Accommodation for Applicants /

Employees with Disabilities: The contractor must be familiar with the requirements for and comply with the Americans with Disabilities Act and all rules and regulations established there under. Employers must provide reasonable accommodation in all employment activities unless to do so would cause an undue hardship.

9. Selection of Subcontractors, Procurement of

Materials and Leasing of Equipment: The contractor shall not discriminate on the grounds of race, color, religion, sex, national origin, age or disability in the selection and retention of subcontractors, including procurement of materials and leases of equipment. The contractor shall take all necessary and reasonable steps to ensure nondiscrimination in the administration of this contract.

a. The contractor shall notify all potential subcontractors and suppliers and lessors of their EEO obligations under this contract.

b. The contractor will use good faith efforts to ensure subcontractor compliance with their EEO obligations.

10. Assurance Required by 49 CFR 26.13(b):

a. The requirements of 49 CFR Part 26 and the State DOT's U.S. DOT-approved DBE program are incorporated by reference.

b. The contractor or subcontractor shall not discriminate on the basis of race, color, national origin, or sex in the performance of this contract. The contractor shall carry out applicable requirements of 49 CFR Part 26 in the award and administration of DOT-assisted contracts. Failure

by the contractor to carry out these requirements is a material breach of this contract, which may result in the termination of this contract or such other remedy as the contracting agency deems appropriate.

11. Records and Reports: The contractor shall keep such records as necessary to document compliance with the EEO requirements. Such records shall be retained for a period of three years following the date of the final payment to the contractor for all contract work and shall be available at reasonable times and places for inspection by authorized representatives of the contracting agency and the FHWA.

a. The records kept by the contractor shall document the following:

(1) The number and work hours of minority and non-minority group members and women employed in each work classification on the project;

(2) The progress and efforts being made in cooperation with unions, when applicable, to increase employment opportunities for minorities and women; and

(3) The progress and efforts being made in locating, hiring, training, qualifying, and upgrading minorities and women;

b. The contractors and subcontractors will submit an annual report to the contracting agency each July for the duration of the project, indicating the number of minority, women, and non-minority group employees currently engaged in each work classification required by the contract work. This information is to be reported on [Form FHWA-1391](#). The staffing data should represent the project work force on board in all or any part of the last payroll period preceding the end of July. If on-the-job training is being required by special provision, the contractor will be required to collect and report training data. The employment data should reflect the work force on board during all or any part of the last payroll period preceding the end of July.

III. NONSEGREGATED FACILITIES

This provision is applicable to all Federal-aid construction contracts and to all related construction subcontracts of \$10,000 or more.

The contractor must ensure that facilities provided for employees are provided in such a manner that segregation on the basis of race, color, religion, sex, or national origin cannot result. The contractor may neither require such segregated use by written or oral policies nor tolerate such use by employee custom. The contractor's obligation extends further to ensure that its employees are not assigned to perform their services at any location, under the contractor's control, where the facilities are segregated. The term "facilities" includes waiting rooms, work areas, restaurants and other eating areas, time clocks, restrooms, washrooms, locker rooms, and other storage or dressing areas, parking lots, drinking fountains, recreation or entertainment areas, transportation, and housing provided for employees. The contractor shall provide separate or single-user restrooms and necessary dressing or sleeping areas to assure privacy between sexes.

IV. DAVIS-BACON AND RELATED ACT PROVISIONS

This section is applicable to all Federal-aid construction projects exceeding \$2,000 and to all related subcontracts and lower-tier subcontracts (regardless of subcontract size). The requirements apply to all projects located within the right-of-way of a roadway that is functionally classified as Federal-aid highway. This excludes roadways functionally classified as local roads or rural minor collectors, which are exempt. Contracting agencies may elect to apply these requirements to other projects.

The following provisions are from the U.S. Department of Labor regulations in 29 CFR 5.5 "Contract provisions and related matters" with minor revisions to conform to the FHWA-1273 format and FHWA program requirements.

1. Minimum wages

a. All laborers and mechanics employed or working upon the site of the work, will be paid unconditionally and not less often than once a week, and without subsequent deduction or rebate on any account (except such payroll deductions as are permitted by regulations issued by the Secretary of Labor under the Copeland Act (29 CFR part 3)), the full amount of wages and bona fide fringe benefits (or cash equivalents thereof) due at time of payment computed at rates not less than those contained in the wage determination of the Secretary of Labor which is attached hereto and made a part hereof, regardless of any contractual relationship which may be alleged to exist between the contractor and such laborers and mechanics.

Contributions made or costs reasonably anticipated for bona fide fringe benefits under section 1(b)(2) of the Davis-Bacon Act on behalf of laborers or mechanics are considered wages paid to such laborers or mechanics, subject to the provisions of paragraph 1.d. of this section; also, regular contributions made or costs incurred for more than a weekly period (but not less often than quarterly) under plans, funds, or programs which cover the particular weekly period, are deemed to be constructively made or incurred during such weekly period. Such laborers and mechanics shall be paid the appropriate wage rate and fringe benefits on the wage determination for the classification of work actually performed, without regard to skill, except as provided in 29 CFR 5.5(a)(4). Laborers or mechanics performing work in more than one classification may be compensated at the rate specified for each classification for the time actually worked therein: Provided, that the employer's payroll records accurately set forth the time spent in each classification in which work is performed. The wage determination (including any additional classification and wage rates conformed under paragraph 1.b. of this section) and the Davis-Bacon poster (WH-1321) shall be posted at all times by the contractor and its subcontractors at the site of the work in a prominent and accessible place where it can be easily seen by the workers.

b. (1) The contracting officer shall require that any class of laborers or mechanics, including helpers, which is not listed in the wage determination and which is to be employed under the contract shall be classified in conformance with the wage determination. The contracting officer shall approve an additional classification and wage

rate and fringe benefits therefore only when the following criteria have been met:

(i) The work to be performed by the classification requested is not performed by a classification in the wage determination; and

(ii) The classification is utilized in the area by the construction industry; and

(iii) The proposed wage rate, including any bona fide fringe benefits, bears a reasonable relationship to the wage rates contained in the wage determination.

(2) If the contractor and the laborers and mechanics to be employed in the classification (if known), or their representatives, and the contracting officer agree on the classification and wage rate (including the amount designated for fringe benefits where appropriate), a report of the action taken shall be sent by the contracting officer to the Administrator of the Wage and Hour Division, Employment Standards Administration, U.S. Department of Labor, Washington, DC 20210. The Administrator, or an authorized representative, will approve, modify, or disapprove every additional classification action within 30 days of receipt and so advise the contracting officer or will notify the contracting officer within the 30-day period that additional time is necessary.

(3) In the event the contractor, the laborers or mechanics to be employed in the classification or their representatives, and the contracting officer do not agree on the proposed classification and wage rate (including the amount designated for fringe benefits, where appropriate), the contracting officer shall refer the questions, including the views of all interested parties and the recommendation of the contracting officer, to the Wage and Hour Administrator for determination. The Wage and Hour Administrator, or an authorized representative, will issue a determination within 30 days of receipt and so advise the contracting officer or will notify the contracting officer within the 30-day period that additional time is necessary.

(4) The wage rate (including fringe benefits where appropriate) determined pursuant to paragraphs 1.b.(2) or 1.b.(3) of this section, shall be paid to all workers performing work in the classification under this contract from the first day on which work is performed in the classification.

c. Whenever the minimum wage rate prescribed in the contract for a class of laborers or mechanics includes a fringe benefit which is not expressed as an hourly rate, the contractor shall either pay the benefit as stated in the wage determination or shall pay another bona fide fringe benefit or an hourly cash equivalent thereof.

d. If the contractor does not make payments to a trustee or other third person, the contractor may consider as part of the wages of any laborer or mechanic the amount of any costs reasonably anticipated in providing bona fide fringe benefits under a plan or program, Provided, That the Secretary of Labor has found, upon the written request of the contractor, that the applicable standards of the Davis-Bacon Act have been met. The Secretary of Labor may require the contractor

to set aside in a separate account assets for the meeting of obligations under the plan or program.

2. Withholding

The contracting agency shall upon its own action or upon written request of an authorized representative of the Department of Labor, withhold or cause to be withheld from the contractor under this contract, or any other Federal contract with the same prime contractor, or any other federally-assisted contract subject to Davis-Bacon prevailing wage requirements, which is held by the same prime contractor, so much of the accrued payments or advances as may be considered necessary to pay laborers and mechanics, including apprentices, trainees, and helpers, employed by the contractor or any subcontractor the full amount of wages required by the contract. In the event of failure to pay any laborer or mechanic, including any apprentice, trainee, or helper, employed or working on the site of the work, all or part of the wages required by the contract, the contracting agency may, after written notice to the contractor, take such action as may be necessary to cause the suspension of any further payment, advance, or guarantee of funds until such violations have ceased.

3. Payrolls and basic records

a. Payrolls and basic records relating thereto shall be maintained by the contractor during the course of the work and preserved for a period of three years thereafter for all laborers and mechanics working at the site of the work. Such records shall contain the name, address, and social security number of each such worker, his or her correct classification, hourly rates of wages paid (including rates of contributions or costs anticipated for bona fide fringe benefits or cash equivalents thereof of the types described in section 1(b)(2)(B) of the Davis-Bacon Act), daily and weekly number of hours worked, deductions made and actual wages paid. Whenever the Secretary of Labor has found under 29 CFR 5.5(a)(1)(iv) that the wages of any laborer or mechanic include the amount of any costs reasonably anticipated in providing benefits under a plan or program described in section 1(b)(2)(B) of the Davis-Bacon Act, the contractor shall maintain records which show that the commitment to provide such benefits is enforceable, that the plan or program is financially responsible, and that the plan or program has been communicated in writing to the laborers or mechanics affected, and records which show the costs anticipated or the actual cost incurred in providing such benefits. Contractors employing apprentices or trainees under approved programs shall maintain written evidence of the registration of apprenticeship programs and certification of trainee programs, the registration of the apprentices and trainees, and the ratios and wage rates prescribed in the applicable programs.

b. (1) The contractor shall submit weekly for each week in which any contract work is performed a copy of all payrolls to the contracting agency. The payrolls submitted shall set out accurately and completely all of the information required to be maintained under 29 CFR 5.5(a)(3)(i), except that full social security numbers and home addresses shall not be included on weekly transmittals. Instead the payrolls shall only need to include an individually identifying number

for each employee (e.g., the last four digits of the employee's social security number). The required weekly payroll information may be submitted in any form desired. Optional Form WH-347 is available for this purpose from the Wage and Hour Division Web site at <http://www.dol.gov/esa/whd/forms/wh347instr.htm> or its successor site. The prime contractor is responsible for the submission of copies of payrolls by all subcontractors. Contractors and subcontractors shall maintain the full social security number and current address of each covered worker, and shall provide them upon request to the contracting agency for transmission to the State DOT, the FHWA or the Wage and Hour Division of the Department of Labor for purposes of an investigation or audit of compliance with prevailing wage requirements. It is not a violation of this section for a prime contractor to require a subcontractor to provide addresses and social security numbers to the prime contractor for its own records, without weekly submission to the contracting agency..

(2) Each payroll submitted shall be accompanied by a "Statement of Compliance," signed by the contractor or subcontractor or his or her agent who pays or supervises the payment of the persons employed under the contract and shall certify the following:

(i) That the payroll for the payroll period contains the information required to be provided under §5.5 (a)(3)(ii) of Regulations, 29 CFR part 5, the appropriate information is being maintained under §5.5 (a)(3)(i) of Regulations, 29 CFR part 5, and that such information is correct and complete;

(ii) That each laborer or mechanic (including each helper, apprentice, and trainee) employed on the contract during the payroll period has been paid the full weekly wages earned, without rebate, either directly or indirectly, and that no deductions have been made either directly or indirectly from the full wages earned, other than permissible deductions as set forth in Regulations, 29 CFR part 3;

(iii) That each laborer or mechanic has been paid not less than the applicable wage rates and fringe benefits or cash equivalents for the classification of work performed, as specified in the applicable wage determination incorporated into the contract.

(3) The weekly submission of a properly executed certification set forth on the reverse side of Optional Form WH-347 shall satisfy the requirement for submission of the "Statement of Compliance" required by paragraph 3.b.(2) of this section.

(4) The falsification of any of the above certifications may subject the contractor or subcontractor to civil or criminal prosecution under section 1001 of title 18 and section 231 of title 31 of the United States Code.

c. The contractor or subcontractor shall make the records required under paragraph 3.a. of this section available for inspection, copying, or transcription by authorized representatives of the contracting agency, the State DOT, the FHWA, or the Department of Labor, and shall permit such representatives to interview employees during working

hours on the job. If the contractor or subcontractor fails to submit the required records or to make them available, the FHWA may, after written notice to the contractor, the contracting agency or the State DOT, take such action as may be necessary to cause the suspension of any further payment, advance, or guarantee of funds. Furthermore, failure to submit the required records upon request or to make such records available may be grounds for debarment action pursuant to 29 CFR 5.12.

4. Apprentices and trainees

a. Apprentices (programs of the USDOL).

Apprentices will be permitted to work at less than the predetermined rate for the work they performed when they are employed pursuant to and individually registered in a bona fide apprenticeship program registered with the U.S. Department of Labor, Employment and Training Administration, Office of Apprenticeship Training, Employer and Labor Services, or with a State Apprenticeship Agency recognized by the Office, or if a person is employed in his or her first 90 days of probationary employment as an apprentice in such an apprenticeship program, who is not individually registered in the program, but who has been certified by the Office of Apprenticeship Training, Employer and Labor Services or a State Apprenticeship Agency (where appropriate) to be eligible for probationary employment as an apprentice.

The allowable ratio of apprentices to journeymen on the job site in any craft classification shall not be greater than the ratio permitted to the contractor as to the entire work force under the registered program. Any worker listed on a payroll at an apprentice wage rate, who is not registered or otherwise employed as stated above, shall be paid not less than the applicable wage rate on the wage determination for the classification of work actually performed. In addition, any apprentice performing work on the job site in excess of the ratio permitted under the registered program shall be paid not less than the applicable wage rate on the wage determination for the work actually performed. Where a contractor is performing construction on a project in a locality other than that in which its program is registered, the ratios and wage rates (expressed in percentages of the journeyman's hourly rate) specified in the contractor's or subcontractor's registered program shall be observed.

Every apprentice must be paid at not less than the rate specified in the registered program for the apprentice's level of progress, expressed as a percentage of the journeymen hourly rate specified in the applicable wage determination. Apprentices shall be paid fringe benefits in accordance with the provisions of the apprenticeship program. If the apprenticeship program does not specify fringe benefits, apprentices must be paid the full amount of fringe benefits listed on the wage determination for the applicable classification. If the Administrator determines that a different practice prevails for the applicable apprentice classification, fringes shall be paid in accordance with that determination.

In the event the Office of Apprenticeship Training, Employer and Labor Services, or a State Apprenticeship Agency recognized by the Office, withdraws approval of an apprenticeship program, the contractor will no longer be permitted to utilize apprentices at less than the applicable

predetermined rate for the work performed until an acceptable program is approved.

b. Trainees (programs of the USDOL).

Except as provided in 29 CFR 5.16, trainees will not be permitted to work at less than the predetermined rate for the work performed unless they are employed pursuant to and individually registered in a program which has received prior approval, evidenced by formal certification by the U.S. Department of Labor, Employment and Training Administration.

The ratio of trainees to journeymen on the job site shall not be greater than permitted under the plan approved by the Employment and Training Administration.

Every trainee must be paid at not less than the rate specified in the approved program for the trainee's level of progress, expressed as a percentage of the journeyman hourly rate specified in the applicable wage determination. Trainees shall be paid fringe benefits in accordance with the provisions of the trainee program. If the trainee program does not mention fringe benefits, trainees shall be paid the full amount of fringe benefits listed on the wage determination unless the Administrator of the Wage and Hour Division determines that there is an apprenticeship program associated with the corresponding journeyman wage rate on the wage determination which provides for less than full fringe benefits for apprentices. Any employee listed on the payroll at a trainee rate who is not registered and participating in a training plan approved by the Employment and Training Administration shall be paid not less than the applicable wage rate on the wage determination for the classification of work actually performed. In addition, any trainee performing work on the job site in excess of the ratio permitted under the registered program shall be paid not less than the applicable wage rate on the wage determination for the work actually performed.

In the event the Employment and Training Administration withdraws approval of a training program, the contractor will no longer be permitted to utilize trainees at less than the applicable predetermined rate for the work performed until an acceptable program is approved.

c. Equal employment opportunity. The utilization of apprentices, trainees and journeymen under this part shall be in conformity with the equal employment opportunity requirements of Executive Order 11246, as amended, and 29 CFR part 30.

d. Apprentices and Trainees (programs of the U.S. DOT).

Apprentices and trainees working under apprenticeship and skill training programs which have been certified by the Secretary of Transportation as promoting EEO in connection with Federal-aid highway construction programs are not subject to the requirements of paragraph 4 of this Section IV. The straight time hourly wage rates for apprentices and trainees under such programs will be established by the particular programs. The ratio of apprentices and trainees to journeymen shall not be greater than permitted by the terms of the particular program.

5. Compliance with Copeland Act requirements. The contractor shall comply with the requirements of 29 CFR part 3, which are incorporated by reference in this contract.

6. Subcontracts. The contractor or subcontractor shall insert Form FHWA-1273 in any subcontracts and also require the subcontractors to include Form FHWA-1273 in any lower tier subcontracts. The prime contractor shall be responsible for the compliance by any subcontractor or lower tier subcontractor with all the contract clauses in 29 CFR 5.5.

7. Contract termination: debarment. A breach of the contract clauses in 29 CFR 5.5 may be grounds for termination of the contract, and for debarment as a contractor and a subcontractor as provided in 29 CFR 5.12.

8. Compliance with Davis-Bacon and Related Act requirements. All rulings and interpretations of the Davis-Bacon and Related Acts contained in 29 CFR parts 1, 3, and 5 are herein incorporated by reference in this contract.

9. Disputes concerning labor standards. Disputes arising out of the labor standards provisions of this contract shall not be subject to the general disputes clause of this contract. Such disputes shall be resolved in accordance with the procedures of the Department of Labor set forth in 29 CFR parts 5, 6, and 7. Disputes within the meaning of this clause include disputes between the contractor (or any of its subcontractors) and the contracting agency, the U.S. Department of Labor, or the employees or their representatives.

10. Certification of eligibility.

a. By entering into this contract, the contractor certifies that neither it (nor he or she) nor any person or firm who has an interest in the contractor's firm is a person or firm ineligible to be awarded Government contracts by virtue of section 3(a) of the Davis-Bacon Act or 29 CFR 5.12(a)(1).

b. No part of this contract shall be subcontracted to any person or firm ineligible for award of a Government contract by virtue of section 3(a) of the Davis-Bacon Act or 29 CFR 5.12(a)(1).

c. The penalty for making false statements is prescribed in the U.S. Criminal Code, 18 U.S.C. 1001.

V. CONTRACT WORK HOURS AND SAFETY STANDARDS ACT

The following clauses apply to any Federal-aid construction contract in an amount in excess of \$100,000 and subject to the overtime provisions of the Contract Work Hours and Safety Standards Act. These clauses shall be inserted in addition to the clauses required by 29 CFR 5.5(a) or 29 CFR 4.6. As used in this paragraph, the terms laborers and mechanics include watchmen and guards.

1. Overtime requirements. No contractor or subcontractor contracting for any part of the contract work which may require or involve the employment of laborers or mechanics shall require or permit any such laborer or mechanic in any

workweek in which he or she is employed on such work to work in excess of forty hours in such workweek unless such laborer or mechanic receives compensation at a rate not less than one and one-half times the basic rate of pay for all hours worked in excess of forty hours in such workweek.

2. Violation; liability for unpaid wages; liquidated damages. In the event of any violation of the clause set forth in paragraph (1.) of this section, the contractor and any subcontractor responsible therefor shall be liable for the unpaid wages. In addition, such contractor and subcontractor shall be liable to the United States (in the case of work done under contract for the District of Columbia or a territory, to such District or to such territory), for liquidated damages. Such liquidated damages shall be computed with respect to each individual laborer or mechanic, including watchmen and guards, employed in violation of the clause set forth in paragraph (1.) of this section, in the sum of \$10 for each calendar day on which such individual was required or permitted to work in excess of the standard workweek of forty hours without payment of the overtime wages required by the clause set forth in paragraph (1.) of this section.

3. Withholding for unpaid wages and liquidated damages. The FHWA or the contacting agency shall upon its own action or upon written request of an authorized representative of the Department of Labor withhold or cause to be withheld, from any moneys payable on account of work performed by the contractor or subcontractor under any such contract or any other Federal contract with the same prime contractor, or any other federally-assisted contract subject to the Contract Work Hours and Safety Standards Act, which is held by the same prime contractor, such sums as may be determined to be necessary to satisfy any liabilities of such contractor or subcontractor for unpaid wages and liquidated damages as provided in the clause set forth in paragraph (2.) of this section.

4. Subcontracts. The contractor or subcontractor shall insert in any subcontracts the clauses set forth in paragraph (1.) through (4.) of this section and also a clause requiring the subcontractors to include these clauses in any lower tier subcontracts. The prime contractor shall be responsible for compliance by any subcontractor or lower tier subcontractor with the clauses set forth in paragraphs (1.) through (4.) of this section.

VI. SUBLETTING OR ASSIGNING THE CONTRACT

This provision is applicable to all Federal-aid construction contracts on the National Highway System.

1. The contractor shall perform with its own organization contract work amounting to not less than 30 percent (or a greater percentage if specified elsewhere in the contract) of the total original contract price, excluding any specialty items designated by the contracting agency. Specialty items may be performed by subcontract and the amount of any such specialty items performed may be deducted from the total original contract price before computing the amount of work required to be performed by the contractor's own organization (23 CFR 635.116).

a. The term "perform work with its own organization" refers to workers employed or leased by the prime contractor, and equipment owned or rented by the prime contractor, with or

without operators. Such term does not include employees or equipment of a subcontractor or lower tier subcontractor, agents of the prime contractor, or any other assignees. The term may include payments for the costs of hiring leased employees from an employee leasing firm meeting all relevant Federal and State regulatory requirements. Leased employees may only be included in this term if the prime contractor meets all of the following conditions:

(1) The prime contractor maintains control over the supervision of the day-to-day activities of the leased employees;

(2) The prime contractor remains responsible for the quality of the work of the leased employees;

(3) The prime contractor retains all power to accept or exclude individual employees from work on the project; and

(4) The prime contractor remains ultimately responsible for the payment of predetermined minimum wages, the submission of payrolls, statements of compliance and all other Federal regulatory requirements.

b. "Specialty Items" shall be construed to be limited to work that requires highly specialized knowledge, abilities, or equipment not ordinarily available in the type of contracting organizations qualified and expected to bid or propose on the contract as a whole and in general are to be limited to minor components of the overall contract.

2. The contract amount upon which the requirements set forth in paragraph (1) of Section VI is computed includes the cost of material and manufactured products which are to be purchased or produced by the contractor under the contract provisions.

3. The contractor shall furnish (a) a competent superintendent or supervisor who is employed by the firm, has full authority to direct performance of the work in accordance with the contract requirements, and is in charge of all construction operations (regardless of who performs the work) and (b) such other of its own organizational resources (supervision, management, and engineering services) as the contracting officer determines is necessary to assure the performance of the contract.

4. No portion of the contract shall be sublet, assigned or otherwise disposed of except with the written consent of the contracting officer, or authorized representative, and such consent when given shall not be construed to relieve the contractor of any responsibility for the fulfillment of the contract. Written consent will be given only after the contracting agency has assured that each subcontract is evidenced in writing and that it contains all pertinent provisions and requirements of the prime contract.

5. The 30% self-performance requirement of paragraph (1) is not applicable to design-build contracts; however, contracting agencies may establish their own self-performance requirements.

VII. SAFETY: ACCIDENT PREVENTION

This provision is applicable to all Federal-aid construction contracts and to all related subcontracts.

1. In the performance of this contract the contractor shall comply with all applicable Federal, State, and local laws governing safety, health, and sanitation (23 CFR 635). The

contractor shall provide all safeguards, safety devices and protective equipment and take any other needed actions as it determines, or as the contracting officer may determine, to be reasonably necessary to protect the life and health of employees on the job and the safety of the public and to protect property in connection with the performance of the work covered by the contract.

2. It is a condition of this contract, and shall be made a condition of each subcontract, which the contractor enters into pursuant to this contract, that the contractor and any subcontractor shall not permit any employee, in performance of the contract, to work in surroundings or under conditions which are unsanitary, hazardous or dangerous to his/her health or safety, as determined under construction safety and health standards (29 CFR 1926) promulgated by the Secretary of Labor, in accordance with Section 107 of the Contract Work Hours and Safety Standards Act (40 U.S.C. 3704).

3. Pursuant to 29 CFR 1926.3, it is a condition of this contract that the Secretary of Labor or authorized representative thereof, shall have right of entry to any site of contract performance to inspect or investigate the matter of compliance with the construction safety and health standards and to carry out the duties of the Secretary under Section 107 of the Contract Work Hours and Safety Standards Act (40 U.S.C.3704).

VIII. FALSE STATEMENTS CONCERNING HIGHWAY PROJECTS

This provision is applicable to all Federal-aid construction contracts and to all related subcontracts.

In order to assure high quality and durable construction in conformity with approved plans and specifications and a high degree of reliability on statements and representations made by engineers, contractors, suppliers, and workers on Federal-aid highway projects, it is essential that all persons concerned with the project perform their functions as carefully, thoroughly, and honestly as possible. Willful falsification, distortion, or misrepresentation with respect to any facts related to the project is a violation of Federal law. To prevent any misunderstanding regarding the seriousness of these and similar acts, Form FHWA-1022 shall be posted on each Federal-aid highway project (23 CFR 635) in one or more places where it is readily available to all persons concerned with the project:

18 U.S.C. 1020 reads as follows:

"Whoever, being an officer, agent, or employee of the United States, or of any State or Territory, or whoever, whether a person, association, firm, or corporation, knowingly makes any false statement, false representation, or false report as to the character, quality, quantity, or cost of the material used or to be used, or the quantity or quality of the work performed or to be performed, or the cost thereof in connection with the submission of plans, maps, specifications, contracts, or costs of construction on any highway or related project submitted for approval to the Secretary of Transportation; or

Whoever knowingly makes any false statement, false representation, false report or false claim with respect to the character, quality, quantity, or cost of any work performed or

to be performed, or materials furnished or to be furnished, in connection with the construction of any highway or related project approved by the Secretary of Transportation; or

Whoever knowingly makes any false statement or false representation as to material fact in any statement, certificate, or report submitted pursuant to provisions of the Federal-aid Roads Act approved July 1, 1916, (39 Stat. 355), as amended and supplemented;

Shall be fined under this title or imprisoned not more than 5 years or both."

IX. IMPLEMENTATION OF CLEAN AIR ACT AND FEDERAL WATER POLLUTION CONTROL ACT

This provision is applicable to all Federal-aid construction contracts and to all related subcontracts.

By submission of this bid/proposal or the execution of this contract, or subcontract, as appropriate, the bidder, proposer, Federal-aid construction contractor, or subcontractor, as appropriate, will be deemed to have stipulated as follows:

1. That any person who is or will be utilized in the performance of this contract is not prohibited from receiving an award due to a violation of Section 508 of the Clean Water Act or Section 306 of the Clean Air Act.

2. That the contractor agrees to include or cause to be included the requirements of paragraph (1) of this Section X in every subcontract, and further agrees to take such action as the contracting agency may direct as a means of enforcing such requirements.

X. CERTIFICATION REGARDING DEBARMENT, SUSPENSION, INELIGIBILITY AND VOLUNTARY EXCLUSION

This provision is applicable to all Federal-aid construction contracts, design-build contracts, subcontracts, lower-tier subcontracts, purchase orders, lease agreements, consultant contracts or any other covered transaction requiring FHWA approval or that is estimated to cost \$25,000 or more – as defined in 2 CFR Parts 180 and 1200.

1. Instructions for Certification – First Tier Participants:

a. By signing and submitting this proposal, the prospective first tier participant is providing the certification set out below.

b. The inability of a person to provide the certification set out below will not necessarily result in denial of participation in this covered transaction. The prospective first tier participant shall submit an explanation of why it cannot provide the certification set out below. The certification or explanation will be considered in connection with the department or agency's determination whether to enter into this transaction. However, failure of the prospective first tier participant to furnish a certification or an explanation shall disqualify such a person from participation in this transaction.

c. The certification in this clause is a material representation of fact upon which reliance was placed when

the contracting agency determined to enter into this transaction. If it is later determined that the prospective participant knowingly rendered an erroneous certification, in addition to other remedies available to the Federal Government, the contracting agency may terminate this transaction for cause of default.

d. The prospective first tier participant shall provide immediate written notice to the contracting agency to whom this proposal is submitted if any time the prospective first tier participant learns that its certification was erroneous when submitted or has become erroneous by reason of changed circumstances.

e. The terms "covered transaction," "debarred," "suspended," "ineligible," "participant," "person," "principal," and "voluntarily excluded," as used in this clause, are defined in 2 CFR Parts 180 and 1200. "First Tier Covered Transactions" refers to any covered transaction between a grantee or subgrantee of Federal funds and a participant (such as the prime or general contract). "Lower Tier Covered Transactions" refers to any covered transaction under a First Tier Covered Transaction (such as subcontracts). "First Tier Participant" refers to the participant who has entered into a covered transaction with a grantee or subgrantee of Federal funds (such as the prime or general contractor). "Lower Tier Participant" refers any participant who has entered into a covered transaction with a First Tier Participant or other Lower Tier Participants (such as subcontractors and suppliers).

f. The prospective first tier participant agrees by submitting this proposal that, should the proposed covered transaction be entered into, it shall not knowingly enter into any lower tier covered transaction with a person who is debarred, suspended, declared ineligible, or voluntarily excluded from participation in this covered transaction, unless authorized by the department or agency entering into this transaction.

g. The prospective first tier participant further agrees by submitting this proposal that it will include the clause titled "Certification Regarding Debarment, Suspension, Ineligibility and Voluntary Exclusion-Lower Tier Covered Transactions," provided by the department or contracting agency, entering into this covered transaction, without modification, in all lower tier covered transactions and in all solicitations for lower tier covered transactions exceeding the \$25,000 threshold.

h. A participant in a covered transaction may rely upon a certification of a prospective participant in a lower tier covered transaction that is not debarred, suspended, ineligible, or voluntarily excluded from the covered transaction, unless it knows that the certification is erroneous. A participant is responsible for ensuring that its principals are not suspended, debarred, or otherwise ineligible to participate in covered transactions. To verify the eligibility of its principals, as well as the eligibility of any lower tier prospective participants, each participant may, but is not required to, check the Excluded Parties List System website (<https://www.epls.gov/>), which is compiled by the General Services Administration.

i. Nothing contained in the foregoing shall be construed to require the establishment of a system of records in order to render in good faith the certification required by this clause. The knowledge and information of the prospective participant is not required to exceed that which is normally

possessed by a prudent person in the ordinary course of business dealings.

j. Except for transactions authorized under paragraph (f) of these instructions, if a participant in a covered transaction knowingly enters into a lower tier covered transaction with a person who is suspended, debarred, ineligible, or voluntarily excluded from participation in this transaction, in addition to other remedies available to the Federal Government, the department or agency may terminate this transaction for cause or default.

* * * * *

2. Certification Regarding Debarment, Suspension, Ineligibility and Voluntary Exclusion – First Tier Participants:

a. The prospective first tier participant certifies to the best of its knowledge and belief, that it and its principals:

(1) Are not presently debarred, suspended, proposed for debarment, declared ineligible, or voluntarily excluded from participating in covered transactions by any Federal department or agency;

(2) Have not within a three-year period preceding this proposal been convicted of or had a civil judgment rendered against them for commission of fraud or a criminal offense in connection with obtaining, attempting to obtain, or performing a public (Federal, State or local) transaction or contract under a public transaction; violation of Federal or State antitrust statutes or commission of embezzlement, theft, forgery, bribery, falsification or destruction of records, making false statements, or receiving stolen property;

(3) Are not presently indicted for or otherwise criminally or civilly charged by a governmental entity (Federal, State or local) with commission of any of the offenses enumerated in paragraph (a)(2) of this certification; and

(4) Have not within a three-year period preceding this application/proposal had one or more public transactions (Federal, State or local) terminated for cause or default.

b. Where the prospective participant is unable to certify to any of the statements in this certification, such prospective participant shall attach an explanation to this proposal.

2. Instructions for Certification - Lower Tier Participants:

(Applicable to all subcontracts, purchase orders and other lower tier transactions requiring prior FHWA approval or estimated to cost \$25,000 or more - 2 CFR Parts 180 and 1200)

a. By signing and submitting this proposal, the prospective lower tier is providing the certification set out below.

b. The certification in this clause is a material representation of fact upon which reliance was placed when this transaction was entered into. If it is later determined that the prospective lower tier participant knowingly rendered an erroneous certification, in addition to other remedies available to the Federal Government, the department, or agency with which this transaction originated may pursue available remedies, including suspension and/or debarment.

c. The prospective lower tier participant shall provide immediate written notice to the person to which this proposal is submitted if at any time the prospective lower tier participant learns that its certification was erroneous by reason of changed circumstances.

d. The terms "covered transaction," "debarred," "suspended," "ineligible," "participant," "person," "principal," and "voluntarily excluded," as used in this clause, are defined in 2 CFR Parts 180 and 1200. You may contact the person to which this proposal is submitted for assistance in obtaining a copy of those regulations. "First Tier Covered Transactions" refers to any covered transaction between a grantee or subgrantee of Federal funds and a participant (such as the prime or general contract). "Lower Tier Covered Transactions" refers to any covered transaction under a First Tier Covered Transaction (such as subcontracts). "First Tier Participant" refers to the participant who has entered into a covered transaction with a grantee or subgrantee of Federal funds (such as the prime or general contractor). "Lower Tier Participant" refers any participant who has entered into a covered transaction with a First Tier Participant or other Lower Tier Participants (such as subcontractors and suppliers).

e. The prospective lower tier participant agrees by submitting this proposal that, should the proposed covered transaction be entered into, it shall not knowingly enter into any lower tier covered transaction with a person who is debarred, suspended, declared ineligible, or voluntarily excluded from participation in this covered transaction, unless authorized by the department or agency with which this transaction originated.

f. The prospective lower tier participant further agrees by submitting this proposal that it will include this clause titled "Certification Regarding Debarment, Suspension, Ineligibility and Voluntary Exclusion-Lower Tier Covered Transaction," without modification, in all lower tier covered transactions and in all solicitations for lower tier covered transactions exceeding the \$25,000 threshold.

g. A participant in a covered transaction may rely upon a certification of a prospective participant in a lower tier covered transaction that is not debarred, suspended, ineligible, or voluntarily excluded from the covered transaction, unless it knows that the certification is erroneous. A participant is responsible for ensuring that its principals are not suspended, debarred, or otherwise ineligible to participate in covered transactions. To verify the eligibility of its principals, as well as the eligibility of any lower tier prospective participants, each participant may, but is not required to, check the Excluded Parties List System website (<https://www.epls.gov/>), which is compiled by the General Services Administration.

h. Nothing contained in the foregoing shall be construed to require establishment of a system of records in order to render in good faith the certification required by this clause. The knowledge and information of participant is not required to exceed that which is normally possessed by a prudent person in the ordinary course of business dealings.

i. Except for transactions authorized under paragraph e of these instructions, if a participant in a covered transaction knowingly enters into a lower tier covered transaction with a person who is suspended, debarred, ineligible, or voluntarily excluded from participation in this transaction, in addition to other remedies available to the Federal Government, the

department or agency with which this transaction originated may pursue available remedies, including suspension and/or debarment.

* * * * *

Certification Regarding Debarment, Suspension, Ineligibility and Voluntary Exclusion--Lower Tier Participants:

- 1. The prospective lower tier participant certifies, by submission of this proposal, that neither it nor its principals is presently debarred, suspended, proposed for debarment, declared ineligible, or voluntarily excluded from participating in covered transactions by any Federal department or agency.
- 2. Where the prospective lower tier participant is unable to certify to any of the statements in this certification, such prospective participant shall attach an explanation to this proposal.

* * * * *

XI. CERTIFICATION REGARDING USE OF CONTRACT FUNDS FOR LOBBYING

This provision is applicable to all Federal-aid construction contracts and to all related subcontracts which exceed \$100,000 (49 CFR 20).

- 1. The prospective participant certifies, by signing and submitting this bid or proposal, to the best of his or her knowledge and belief, that:
 - a. No Federal appropriated funds have been paid or will be paid, by or on behalf of the undersigned, to any person for influencing or attempting to influence an officer or employee of any Federal agency, a Member of Congress, an officer or employee of Congress, or an employee of a Member of Congress in connection with the awarding of any Federal contract, the making of any Federal grant, the making of any Federal loan, the entering into of any cooperative agreement, and the extension, continuation, renewal, amendment, or modification of any Federal contract, grant, loan, or cooperative agreement.
 - b. If any funds other than Federal appropriated funds have been paid or will be paid to any person for influencing or attempting to influence an officer or employee of any Federal agency, a Member of Congress, an officer or employee of Congress, or an employee of a Member of Congress in connection with this Federal contract, grant, loan, or cooperative agreement, the undersigned shall complete and submit Standard Form-LLL, "Disclosure Form to Report Lobbying," in accordance with its instructions.
- 2. This certification is a material representation of fact upon which reliance was placed when this transaction was made or entered into. Submission of this certification is a prerequisite for making or entering into this transaction imposed by 31 U.S.C. 1352. Any person who fails to file the required certification shall be subject to a civil penalty of not less than \$10,000 and not more than \$100,000 for each such failure.
- 3. The prospective participant also agrees by submitting its bid or proposal that the participant shall require that the language of this certification be included in all lower tier

subcontracts, which exceed \$100,000 and that all such recipients shall certify and disclose accordingly.

ATTACHMENT A - EMPLOYMENT AND MATERIALS PREFERENCE FOR APPALACHIAN DEVELOPMENT HIGHWAY SYSTEM OR APPALACHIAN LOCAL ACCESS ROAD CONTRACTS

This provision is applicable to all Federal-aid projects funded under the Appalachian Regional Development Act of 1965.

- 1. During the performance of this contract, the contractor undertaking to do work which is, or reasonably may be, done as on-site work, shall give preference to qualified persons who regularly reside in the labor area as designated by the DOL wherein the contract work is situated, or the subregion, or the Appalachian counties of the State wherein the contract work is situated, except:
 - a. To the extent that qualified persons regularly residing in the area are not available.
 - b. For the reasonable needs of the contractor to employ supervisory or specially experienced personnel necessary to assure an efficient execution of the contract work.
 - c. For the obligation of the contractor to offer employment to present or former employees as the result of a lawful collective bargaining contract, provided that the number of nonresident persons employed under this subparagraph (1c) shall not exceed 20 percent of the total number of employees employed by the contractor on the contract work, except as provided in subparagraph (4) below.
- 2. The contractor shall place a job order with the State Employment Service indicating (a) the classifications of the laborers, mechanics and other employees required to perform the contract work, (b) the number of employees required in each classification, (c) the date on which the participant estimates such employees will be required, and (d) any other pertinent information required by the State Employment Service to complete the job order form. The job order may be placed with the State Employment Service in writing or by telephone. If during the course of the contract work, the information submitted by the contractor in the original job order is substantially modified, the participant shall promptly notify the State Employment Service.
- 3. The contractor shall give full consideration to all qualified job applicants referred to him by the State Employment Service. The contractor is not required to grant employment to any job applicants who, in his opinion, are not qualified to perform the classification of work required.
- 4. If, within one week following the placing of a job order by the contractor with the State Employment Service, the State Employment Service is unable to refer any qualified job applicants to the contractor, or less than the number requested, the State Employment Service will forward a certificate to the contractor indicating the unavailability of applicants. Such certificate shall be made a part of the contractor's permanent project records. Upon receipt of this certificate, the contractor may employ persons who do not normally reside in the labor area to fill positions covered by the certificate, notwithstanding the provisions of subparagraph (1c) above.
- 5. The provisions of 23 CFR 633.207(e) allow the contracting agency to provide a contractual preference for

the use of mineral resource materials native to the Appalachian region.

6. The contractor shall include the provisions of Sections 1 through 4 of this Attachment A in every subcontract for work which is, or reasonably may be, done as on-site work.

Appendix A

Checklist for Bidders- Federally Funded Projects with a DBE Goal

- Quotes have been obtained by DBE firms for participation on the project
- NAICS codes have been verified on the Ohio Unified DBE Directory that the DBE firms to be utilized can be applied toward the project goal for the specific work wanted:
<http://www.dot.state.oh.us/Divisions/ODI/SDBE/Pages/DBE-Directory.aspx>
- DBE Utilization Plan has been completed & submitted electronically prior to bid opening via: https://odot.formstack.com/forms/dbe_copy (This applies to all Bidders including DBE Firms)
- The Utilization Plan submitted as described above, meets or exceeds the DBE Goal established for the project

5/29/2020 Revision

- If the DBE Goal has not been met that Good Faith Efforts have been submitted prior to bid to opening to: Dot.contractslettingmgr@dot.ohio.gov

- The affirmation form that is required 5 calendar days after bid opening has been downloaded ready to send out to all DBE firms listed on the Utilization Plan: <http://Transportation.ohio.gov/Divisions/ODI/SDBE/Pages/Resources.aspx>.

ODOT Construction and Material Specifications Section 100

(NOTE: Mentor specifications supersede any specification included within this document)

STATE OF OHIO
DEPARTMENT OF
TRANSPORTATION
COLUMBUS, OHIO

LPA
CONSTRUCTION AND MATERIAL
SPECIFICATIONS

PROPOSAL NOTE 100



An Equal Opportunity Employer

Modified By: [Allen E. Pennington, P.E.](#)
Local Public Agency: [City of Mentor](#)
Date: [07/22/20](#)

Table of Contents

100 GENERAL PROVISIONS ~~43~~

101 DEFINITIONS AND TERMS ~~43~~

102 BIDDING REQUIREMENTS AND CONDITIONS ~~1312~~

103 AWARD AND EXECUTION OF CONTRACT ~~1716~~

104 SCOPE OF WORK ~~1716~~

105 CONTROL OF WORK ~~2221~~

106 CONTROL OF MATERIAL ~~2928~~

107 LEGAL RELATIONS AND RESPONSIBILITY TO PUBLIC ~~3231~~

108 PROSECUTION AND PROGRESS ~~4241~~

109 ACCEPTANCE, MEASUREMENT, AND PAYMENT ~~5251~~

100 GENERAL PROVISIONS

101 DEFINITIONS AND TERMS

101.01 General. These Construction and Material Specifications are written to the Bidder before award of the Contract and to the Contractor after award of the Contract. The sentences that direct the Contractor to perform Work are written as commands. For example, a requirement to provide cold-weather protection would be expressed as, “Provide cold-weather protection for concrete,” rather than “The Contractor shall provide cold-weather protection for concrete.” In the imperative mood, the subject “the Bidder” or “the Contractor” is understood.

All requirements to be performed by others have been written in the active voice. Sentences written in the active voice identify the party responsible for performing the action. For example, “The Engineer will determine the density of the compacted material.” Certain requirements of the Contractor may also be written in the active voice, rather than the active voice and imperative mood, if the sentence includes requirements for others in addition to the Contractor. For example, “After the Contractor provides initial written notice, the Engineer will revise the Contract as specified in [104.02](#).”

Sentences that define terms, describe a product or desired result, or describe a condition that may exist are written in indicative mood. These types of sentences use verbs requiring no action. For example, “The characteristics of the soils actually encountered in the subgrade may affect the quality of the cement and depth of treatment necessary.”

101.02 Abbreviations. The following abbreviations, when used in the Contract Documents, represent the full text shown.

AAN	American Association of Nurserymen
AASHTO	American Association of State Highway and Transportation Officials
AC	Asphalt Cement (pavement), Alternating Current (traffic)
ACBFS	Air Cooled Blast Furnace Slag (aggregate)
ACI	American Concrete Institute
ACIA	Asynchronous Communications Interface Adapter (traffic controller)
ADT	Average Daily Traffic
ADTT	Average Daily Truck Traffic
AIC	Amps Interrupting Capacity
AISC	American Institute of Steel Construction
AISI	American Iron and Steel Institute
ANFO	Ammonium Nitrate and Fuel Oil
ANSI	American National Standards Institute
AOS	Apparent Opening Size (fabric)
AREA	American Railway Engineering Association
AMRL	AASHTO Material Reference Library
ASCE	American Society of Civil Engineers
ASLA	American Society of Landscape Architects
ASME	American Society of Mechanical Engineers
ASTM	American Society for Testing and Materials
AWG	American Wire Gauge
AWPA	American Wood Preservers' Association
AWS	American Welding Society
AWWA	American Water Works Association
BBR	Bending Beam Rheometer (asphalt binder test)

BMP	Best Management Practice (erosion)
BOF	Basic Oxygen Furnace (aggregate)
BSG	Bulk Specific Gravity
BTEX	Benzene, toluene, ethyl benzene, and xylene (a soil test)
BUSTR	Bureau of Underground Storage Tank Regulations (Division of Fire Marshal)
C&MS	Construction and Material Specifications
CAPWAP	Case Pile Wave Analysis Program
CBAE	Cut Back Asphalt Emulsion
CCRL	Cement and Concrete Reference Laboratory
CCS	Crushed Carbonate Stone
CECI	Contactors Erosion Control Inspector
CFR	Code of Federal Regulations
CIE	Commission Internationale d'Eclairage (illumination)
CPE	Construction Project Engineer (LPA Local-let Project specific)
CPESC	Certified Professional in Erosion and Sediment Control
CRS	Cationic Rapid Set (asphalt emulsion)
CRSI	Concrete Reinforcing Steel Institute
CSS	Cationic Slow Set (asphalt emulsion)
CVN	Charpy V-notch (steel test)
CWT	Hundred Weight (100 lbs)
DC	Direct Current
DCA	District Construction Administrator
DCE	District Construction Engineer
DDD	District Deputy Director
DET	District Engineer of Tests
DGE	District Geotechnical Engineer
DLS	Data Logging System (traffic markings)
DNR	Department of Natural Resources
DRC	Dry Rodded Condition (asphalt aggregate test)
DSR	Dynamic Shear Rheometer (asphalt binder test)
DZA	Deficient Zone Average (concrete test)
EAF	Electric Arc Furnace
EDA	Earth Disturbing Activity
EI	Edison Electric Institute
EIA	Electronic Industries Alliance
EPA	Environmental Protection Agency
EQS	Exceptional Quality Solids (compost)
FAA	Fine Aggregate Angularity (asphalt aggregate)
FCM	Fracture Critical Member (steel test)
FEMA	Federal Emergency Management Agency
FHWA	Federal Highway Administration, Department of Transportation
FRP	Fiber Reinforced Polymer
FSS	Federal Specifications and Standards, General Services Administration
GGBFS	Ground Granulated Blast Furnace Slag
GS	Granulated Slag
HDPE	High Density Polyethylene
HMWM	High Molecular Weight Methacrylate
ICEA	Insulated Cable Engineers Association

IEEE	<u>Institute of Electrical and Electronic Engineers</u>
IES	<u>Illuminating Engineering Society</u>
IMSA	<u>International Municipal Signal Association</u>
IPCEA	<u>Insulated Power Cable Engineers Association</u>
IPS	International Pipe Standard
ISSA	<u>International Slurry Seal Association</u>
ITE	<u>Institute of Transportation Engineers</u>
IZEU	Inorganic Zinc Epoxy Urethane
<u>JMF</u>	Job Mix Formula
LED	Light Emitting Diode
LPA	Local Public Agency
LWT	Loaded Wheel Test (asphalt test)
MBF	Thousand Board Feet (wood)
MC	Medium Cure (asphalt emulsion)
MCB	Microchannel Bus (traffic controller)
MOV	Metal Oxide Varistor (traffic controller)
MPI	Magnetic Particle Inspection (steel test)
MSG	Maximum Specific Gravity (asphalt)
MTD	Maximum Theoretical Density (asphalt)
NACE	<u>National Association of Corrosion Engineers</u>
NCHRP	<u>National Cooperative Highway Research Program</u>
NEMA	<u>National Electrical Manufacturers Association</u>
NHI	<u>National Highway Institute</u>
NIST	<u>National Institute of Standards and Technology</u>
NOI	Notice of Intent
NPDES	<u>National Pollutant Discharge Elimination System</u>
OAC	<u>Ohio Administrative Code</u>
ODOT	<u>Ohio Department of Transportation</u>
OEPA	<u>Ohio Environmental Protection Agency</u>
OH	Open Hearth (aggregate)
OHWM	Ordinary High Water Mark
<u>OMM</u>	<u>Office of Materials Management</u> (the Central Office Laboratory)
OMUTCD	<u>Ohio Manual of Uniform Traffic Control Devices</u>
ORC	<u>Ohio Revised Code</u>
ORDC	<u>Ohio Rail Development Commission</u>
OSHA	<u>Occupational Safety and Health Administration</u>
OTE	<u>Office of Traffic Engineering</u>
OWPCA	<u>Ohio Water Pollution Control Act</u>
OZEU	Organic Zinc Epoxy Urethane
PAT	Project Average Thickness (concrete test)
PAV	Pressure Aging Vessel (asphalt binder test)
PB	Polybutylene (conduit)
PCC	Portland Cement Concrete
PCS	Petroleum Contaminated Soil
PDA	Pile Dynamic Analysis (steel piling)
PE	Polyethylene (conduit)
PG	Performance Grade (asphalt binder grading system)
pH	Potential of Hydrogen

PLS	Pure Live Seed
PRC	Person in Responsible Charge (representation of the Local Public Agency)
PVC	Polyvinyl chloride
QA	Quality Assurance
QC	Quality Control
QCFS	Quality Control Fabricator Specialist (structures)
QCP	Quality Control Program, or Plan, or Points (steel test)
QPL	Qualified Products List
RAP	Reclaimed Asphalt Pavement
RAS	Reclaimed Asphalt Shingles
RC	Rapid Cure (asphalt emulsion)
REA	Rural Electrification Act
RFI	Radio Frequency Interference (traffic controller)
RH	Relative Humidity
RMS	Root Mean Square (traffic controller)
RPCC	Recycled Portland Cement Concrete
RPM	Raised Pavement Marker (traffic)
RS	Rapid Set (asphalt emulsion)
RTFO	Rolling Thin-Film Oven (asphalt binder test)
RUS	Rural Utilities Service
SAE	Society of Automotive Engineers
SBA	Styrene Butadiene Amine
SBR	Styrene Butadiene Rubber
SBS	Styrene Butadiene Styrene
SCD	Standard Construction Drawing
SDS	Safety Data Sheets
SF	Standard Fabricated members (structures)
SI	International System of Units (Metric)
SM	AASHTOWare Project Sitemanager™
SMA	Stone Matrix Asphalt
SPD	Surge Protection Device (traffic controller)
SPST	Single Pole / Single Throw (traffic controller)
SS	Slow Set (asphalt emulsion)
SSD	Saturated Surface Dry (aggregate)
SSPC	Society for Protective Coatings
SWPPP	Storm Water Pollution Prevention Plan
TAP	Traffic Authorized Product
TCE	Trichloroethylene
TMPTA	Tri-methylpropane Tri-acrylate (paint)
TNP	Total Neutralizing Power
TODS	Tourist-Oriented Directional Signs
TSEC	Temporary Sediment and Erosion Control
TSR	Tensile Strength Ratio (asphalt mix test)
UF	Unique Fabricated members (structures)
UL	Underwriters' Laboratories, Inc.
USACE	United States Army Corps of Engineers
USC	United States Code
VA	Verification Acceptance

VAC	Volts Alternating Current
VCA	Volume of Coarse Aggregate (asphalt mix test)
VECP	Value Engineering Change Proposal
VMA	Voids in the Mineral Aggregate
VME	VersaModule Eurocard (traffic controller)
WDT	Watchdog Timer
WEAP	Wave Equation Analysis (steel piling)
WPS	Welding Procedure Specification (steel test)
WZRPM	Work Zone Raised Pavement Marker (traffic)
XCU	Explosion, Collapse and Underground

101.03 Definitions. The following terms or pronouns, when used in the Contract Documents, are defined as follows:

Advertisement. The public announcement, as required by law, inviting Bids for Work to be performed or materials to be furnished.

Award. The written acceptance by the PRC and/or CPE of a Bid.

Bid. The offer of a Bidder, on the prescribed form properly signed and guaranteed, to perform the Work and to furnish the labor and materials at the prices quoted.

Bid Documents. The Bid Documents include the Invitation for Bids, Addenda, Proposal, , contract form and required bonds, Specifications, [Supplemental Specifications](#), Special Provisions, general and detailed plans, Plan notes, standard construction drawings identified in the Plans, notice to Contractor, and any other document designated by the LPA as a Bid Document, all of which constitute one instrument.

Bidder. An individual, firm, or corporation submitting a Bid for the advertised Work, acting directly or through the duly authorized representative, and qualified as provided in the ORC.

Bridge. A structure, including supports, erected over a depression or an obstruction, such as water, a highway, or a railway, and having a track or passageway for carrying traffic or other moving loads and having a length measured along the center of roadway of 10 feet (3.048 m) or more between undercopings of abutments or extreme limits of openings for multiple boxes.

A. Length. The length of a bridge structure is the over-all length measured along the centerline of the roadway surface.

B. Roadway Width. The clear width measured at right angles to the longitudinal centerline of the bridge between the bottom of curbs or guard timbers or, in the case of multiple heights of curbs, between the bottoms of the lower risers. For curb widths of 1 foot (0.3 m) or less, the roadway width is measured between parapets or railings.

Calendar Day or Day. Every day shown on the calendar.

Certified Test Data. A test report from a manufacturer's or an independent laboratory approved by the Director listing actual test results of samples tested for compliance with specified Department and/or LPA requirements. The LPA will accept certified test data from manufacturers' laboratories if their products have been used satisfactorily on prior Department contracts and their test data has been confirmed. Include a statement that the test data furnished is representative of the material furnished to a Department project or to a supplier. The report is identified by number or date and identifies the LPA project or supplier to which the material is shipped. Submit reports signed by a person having legal authority to act for the manufacturer or independent laboratory.

Change Order. A written order issued by the PRC and/or CPE to the Contractor, covering changes to the terms and conditions, plans and/or quantities, within or beyond the scope of the Contract and establishing the basis of payment and time adjustments for the work affected by the changes.

Claims. Disputes that are not settled through the Dispute Resolution and Administrative Claim Process. The Dispute becomes a Claim when the Contractor submits a Notice of Intent to File a Claim.

Completion Date. The date, as shown in the Contract Documents, on which the Work contemplated shall be completed.

Construction Limits. These limits must encompass all Work. This includes removals, room for construction equipment to complete work, site access, etc.

Construction Project Engineer. Designee by the LPA to serve as the main contact for the Contractor, ODOT, FHWA, and any other agencies having an interest in the Project. The CPE is someone who is tasked with managing a Local-let LPA contract who is either a Professional Engineer or is working under the purview of a Professional Engineer.

Contract. The written agreement between the LPA and the Contractor setting forth the obligations of the parties, including, but not limited to, the performance of the Work and the basis of payment.

Contract Bond. The approved forms of security, executed by the Contractor and its Sureties, guaranteeing complete execution of the Work as required by the Contract Documents and the payment of all legal debts pertaining to the construction of the Project which security shall comply with all related provisions.

Contract Documents. The Contract Documents include the Invitation for Bids, Addenda, Proposal, contract form and required bonds, Specifications, [Supplemental Specifications](#), Special Provisions, general and detailed plans, Plan notes, standard construction drawings identified in the Plans, notice to contractor, Change Orders, Supplemental Agreements, Extra Work Contracts, “Accepted” and “Accepted as Noted” Working Drawings, and any other document designated by the LPA as a Contract Document, all of which constitute one instrument.

Contract Item (Pay Item). A specifically described unit of Work for which a price is provided in the Contract.

Contract Price. The amount of compensation bid by the Contractor for a Contract Item in the Proposal or the amount of compensation established for a Contract Item added or modified pursuant to the Contract Documents.

Contract Time. The number of workdays or calendar days, including authorized adjustments, allowed for completion of the Project. When a specified Completion Date is shown in the Contract Documents instead of the number of workdays or calendar days, completion of the Project shall occur on or before that date. Specified Completion Date and Calendar Day Contracts shall be completed on or before the day indicated even when that date is a Saturday, Sunday, or holiday.

Contractor. The individual, firm, or corporation contracting with the LPA for performance of prescribed Work, acting directly or through a duly authorized representative and qualified under the provisions of the ORC, and any amendments thereto.

County. The designated county in which the Work specified is to be done.

Culvert. Any structure not classified as a Bridge that provides an opening under the roadway.

Department. The [Department of Transportation, State of Ohio](#).

Director. Administrative head of the Department appointed by the Governor.

Disputes. Disagreements, matters in question and differences of opinion between the LPA's personnel and the Contractor.

District Testing. The Departments district testing laboratories.

Engineer. Duly authorized agent of the LPA acting within the scope of its authority for purposes of engineering and administration of the Contract. The Engineer can be either the Person in Responsible Charge (PRC) or the Construction Project Engineer (CPE)

Engineered Drawings. A type of Working Drawing that requires the practice of engineering as defined in [ORC 4733.01\(E\)](#). Examples of Engineered Drawings include: Excavation Bracing Plans, Demolition Plans, Erection Plans, Falsework Plans, Cofferdam Plans, Causeway Plans, Jacking and Temporary Support Plans, Plans for Heavy Equipment on Structures, Plans for structures for Maintaining Traffic, and Corrective Work Plans.

Equipment. All machinery and equipment, together with the necessary supplies for upkeep and maintenance, and also tools and apparatus necessary for the proper construction and acceptable completion of the Work.

Extra Work. An item of Work not provided for in the Contract as awarded but found essential to the satisfactory completion of the Contract within its intended scope.

Extra Work Contract. A Contract concerning the performance of Work or furnishing of materials involving Extra Work. Such Extra Work may be performed at agreed prices or on a force account basis.

Fabricator. The individual, firm, or corporation that fabricates structural metals or prestressed concrete members as an agent of the Contractor.

Final Inspector. An Engineer appointed by the (DDD)who inspects the completed Work and accepts it if it complies with the Contract Documents.

Inspector. The Engineer's authorized representative assigned to make detailed inspections of Contract performance.

Invitation for Bids. The invitation for Proposals for all Work on which Bids are required. Such Proposal will indicate with reasonable accuracy the quantity and location of the Work to be done or the character and quality of the material to be furnished and the time and place of the opening of Proposals.

Laboratory. The testing laboratories of the Department, including the ([OMM](#)) located at 1600 West Broad Street, Columbus, Ohio, and the District testing facilities.

Local. The [LPA responsible for managing the construction contract and](#) acting through its authorized representative.

Materials. Any materials or products specified for use in the construction of the Project and its appurtenances.

Partnering. A collaborative process for project cooperation and communication meant to achieve effective and efficient contract performance and completion of the Project within budget, on schedule, safely and with requisite quality in accordance with the contract.

Person in Responsible Charge (PRC). Serves as the agency contact for all issues or inquiries and ensures that all applicable state and federal regulations are followed on the project

Plans. The drawings, standard construction drawings and supplemental drawings provided by the Department that show the location, character, dimensions, and details of the Work.

Prebid Question. A written inquiry submitted by a prospective bidder.

Professional Landscape Architect. A landscape architect registered with the Ohio Landscape Architects Board to practice landscape architecture in the State of Ohio.

Profile Grade. The trace of a vertical plane intersecting the top surface of the proposed wearing surface, usually along the longitudinal centerline of the roadbed. Profile grade means either elevation or gradient of such trace according to the context.

Project Limits. Project limits are points on the mainline centerline of construction where the proposed improvement, as described in the project description on the Title Sheet (excluding incidental construction), begins and ends

Project Right-of-Way. That portion of the Right-of-Way between the beginning and end of the Project.

Project. The specific section of the highway or route together with all appurtenances and/or Work to be performed thereon under the Contract.

Proposal. The approved form on which the LPA requires Bids to be prepared and submitted for the Work.

Proposal Guaranty. The security furnished with a Bid to guarantee that the Bidder will enter into the Contract if its Bid is accepted.

Questionnaire. The specified forms on which the Contractor shall furnish required information as to its ability to perform and finance the Work.

Reasonably Close Conformity. Reasonably close conformity means compliance with reasonable and customary manufacturing and construction tolerances where working tolerances are not specified. Where working tolerances are specified, reasonably close conformity means compliance with such working tolerances. Without detracting from the complete and absolute discretion of the Engineer to insist upon such tolerances as establishing reasonably close conformity, the Engineer may accept variations beyond such tolerances as reasonably close conformity where they will not materially affect the value or utility of the Work and the interests of the LPA.

Registered Engineer. An engineer registered with the [Ohio State Board of Registration for Professional Engineers and Surveyors](#) to practice professional engineering in the State of Ohio

Registered Surveyor. A surveyor registered with the [Ohio State Board of Registration for Professional Engineers and Surveyors](#) to practice professional surveying in the State of Ohio.

Right-of-Way. A general term denoting land, property, or interest therein, usually in a strip, acquired for or devoted to a highway.

Road. A general term denoting a public way for purposes of vehicular travel, including the entire area within the Right-of-Way, as defined in the ORC.

Roadbed. The graded portion of a highway within top and side slopes, prepared as a foundation for the pavement structure and shoulder.

Roadside. The areas between the outside edges of the shoulders and the Right-of-Way boundaries. Unpaved median areas between inside shoulders of divided highways and infield areas of interchanges are included.

Roadside Development. Those items necessary to the highway that provide for the preservation of landscape materials and features; the rehabilitation and protection against erosion of all areas disturbed by construction through seeding, sodding, mulching, and the placing of other ground covers; such suitable planting; and other improvements as may increase the effectiveness and enhance the appearance of the highway.

Roadway. The portion of a highway within limits of construction.

Shop Drawings. Drawings accepted by the Contractor and submitted to the LPA that describe portions of the Work fabricated off site that are incorporated permanently with the project.

Shoulder. The portion of the roadway contiguous to the traveled way for accommodation of stopped vehicles, for emergency use, and for lateral support of base and surface courses.

Sidewalk. That portion of the roadway primarily constructed for the use of pedestrians.

Signatures on Contract Documents. All signatures on Contract Documents must meet the requirements of [102.06](#).

Special Provisions. Additions and revisions to the standard and [Supplemental Specifications](#) covering conditions peculiar to an individual Project.

Specifications. The directions, provisions, and requirements contained herein as supplemented by the [Supplemental Specifications](#) and Special Provisions.

State. The [State of Ohio](#) acting through its authorized representative.

Street. A general term denoting a public way for purpose of vehicular travel, including the entire area within the Right-of-Way.

Structures. Bridges, culverts, catch basins, drop inlets, retaining walls, cribbing, manholes, endwalls, buildings, sewers, service pipes, underdrains, foundation drains, and other features that may be encountered in the Work and not otherwise classed herein.

Subcontractor. An individual, firm, or corporation to whom the Contractor sublets part of the Contract to be performed on the job site, who prior to such undertaking receives the written consent of the Director, and who is qualified under the ORC.

Subgrade. The portion of a Roadbed upon which the pavement structure and shoulders are constructed.

Substructure. All of that part of the structure below the bearings of simple and continuous spans, skewbacks of arches, and tops of footings of rigid frames, together with backwalls and wings.

Superintendent. The Contractor's authorized representative in responsible charge of the Work.

Superstructure. The entire structure except the Substructure.

Supplement. A list of requirements for fabrication plants, methods of test, or other miscellaneous requirements that are maintained on file in the Office of the Director.

Supplemental Agreement. A written agreement executed by the Contractor and by the PRC and/or CPE covering necessary alterations.

Supplemental Specifications. Detailed specifications supplemental to or superseding these Specifications.

Surety. The corporation, partnership, or individual, other than the Contractor, executing a bond furnished by the Contractor.

Titles (or Headings). The titles or headings of the sections and subsections herein are intended for convenience of reference and shall not be considered as having any bearing on their interpretation.

Waters of the United States. Waters that are under the jurisdiction of the Corps of Engineers under the Clean Water Act as defined by [33 CFR Ch. II Part 328](#), which as applied to Ohio means: the Ohio River and Lake Erie and any other river, stream, creek, lake, pond, or wetland that drains directly or indirectly into the Ohio River or Lake Erie.

Work. All labor, materials, equipment, tools, transportation, supplies, and other incidentals and all tasks that comprise the project or any portion thereof, as described by the Contract Documents.

Work Limits. Work Limits are the extreme limits of the contractor's responsibility on a project, including all temporary and incidental construction, with the exception of work zone traffic control devices required for maintenance of traffic.

Workday. A calendar day that the Contractor normally works.

Working Drawings. Contractor submitted drawings for work, not otherwise defined in the Bid Documents, and require LPA acceptance. Examples of Working Drawings include: Engineered Drawings, installation plans, certified drawings, and any other supplementary plans or similar data that the Contractor is required to submit for acceptance.

101.04 Interpretations. In order to avoid cumbersome and confusing repetition of expressions in these Specifications, it is provided that whenever anything is, or is to be, done, if, as, or, when, or where "contemplated, required, determined, directed, specified, authorized, ordered, given, designated, indicated, considered necessary, deemed necessary, permitted, reserved, suspended, established, approval, approved, disapproved, acceptable, unacceptable, suitable, accepted, satisfactory, unsatisfactory, sufficient, insufficient, rejected, or condemned," it shall be understood as if the expression were followed by the words "by the Engineer" or "to the Engineer."

102 BIDDING REQUIREMENTS AND CONDITIONS

102.01 Prequalification of Bidders. A Bidder must be prequalified by the Department according to [ORC Chapter 5525](#) and the rules and regulations governing prequalification in order to submit a Bid. Upon request, the Department will provide a prequalification application, applicable rules and regulations, and other relevant information. For prospective Bidders that are not yet prequalified, furnish the Department with a properly completed prequalification application at least 30 days before the date specified for the receipt of Bids. The prequalification certificate is the Bidder's license to Bid and perform construction for the Department.

Subcontractors are not subject to the prequalification requirement unless otherwise specified by the LPA. The Prime Contractor will perform no less than 30 percent of the total original contract price unless a greater percentage is specified.

For foreign Contractors, refer to [ORC 5525.18](#) and [Ohio Administrative Rule 5501:2-3-07](#).

102.02 Contents of Bid Documents. Use the Proposal to prepare and submit Bids for the Work. Upon request, the LPA will provide Bid Documents that include or reference the following:

- A. Location and description of the Project.
- B. Estimate of quantities and description of the Work.
- C. Time to complete the Work.
- D. Amount of the Proposal Guaranty.
- E. LPA's deadline for receiving a completed Bid.
- F. Schedule of contract items.
- G. Standard Specifications, Special Provisions, [Supplemental Specifications](#), and the Plans.
- H. Proposal.

102.03 Issuance of Proposals.

A. General. Upon request, the LPA will provide applicable rates and other relevant information for obtaining bidding information and submitting a Bid.

B. LPA Will Not Issue. The LPA may refuse to sell or issue Bid Documents to a prospective Bidder for any of the following reasons:

1. The prospective Bidder owes the LPA for previously issued plans.
2. The prospective Bidder has defaulted on previous contracts.
3. The prospective Bidder is debarred from bidding on and receiving Department contracts.
4. The prospective Bidder is currently in the debarment process.

102.04 Interpretation of Quantities in Proposal. The quantities in the Bid Documents are approximate and the LPA uses them for the comparison of Bids only.

The LPA will only pay the Contractor for the actual quantities of Work performed and accepted according to the Contract Documents. The LPA may increase, decrease, or omit the scheduled quantities of Work as provided in [109.04](#) without invalidating the Bid prices.

102.05 Examination of Bid Documents and Project Site and Submission of Prebid Questions.

Carefully examine the Bid Documents and perform a reasonable site investigation before submitting a Bid. Submitting a Bid is an affirmative statement that the Bidder has investigated the Project site and is satisfied as to the character, quality, quantities, and the conditions to be encountered in performing the Work. A reasonable site investigation includes the review of prebid questions, investigating the Project site, borrow sites, hauling routes, and all other locations related to the performance of the Work.

When available, the LPA will include in the Contract Documents or provide for the Bidder's review at the LPA's offices or website, one or more of the following:

- A. Record drawings.
- B. Available information relative to subsurface exploration, borings, soundings, water levels, elevations, or profiles.
- C. The results of other preliminary investigations.

A reasonable site investigation includes a review of these documents.

Should a question arise at any time during the examination of Bid Documents or investigation of the site the Bidder may seek clarification by submitting a Prebid Question. Responses to Prebid Questions by the LPA are not revisions to the Bidding Documents and are not binding.

102.06 Preparation of Bids.

~~LPA SHALL SPECIFY~~ [Omitted – See bid documents within contract book.](#)

102.07 Duty to Notify of Errors in Bid Documents. Notify the LPA of errors and omissions in the Bid Documents. The Contractor's duty to disclose errors and omissions is not only a bidding requirement but is also a legal requirement that cannot be ignored.

Failure to provide the required notification prior to the opening of bids shall constitute a waiver by the Contractor and does not obligate the LPA for any costs based upon any apparent or patent ambiguity arising from insufficient data or obvious errors in the Bid documents. Knowingly withholding information regarding an error or omission in the Bid Documents, or intentionally misrepresenting an

item of Work for financial or competitive gain may result in civil or criminal penalties in excess of the value of the item bid.

102.08 Unbalanced Bidding. Bid all items correctly and price each quantity as indicated in the Bid Documents. The LPA will reject a Mathematically Unbalanced Bid if the Bid is also Materially Unbalanced. A Mathematically Unbalanced Bid is a Bid containing lump sum or unit price items that do not include reasonable labor, equipment, and material costs plus a reasonable proportionate share of the Bidder's overhead costs, other indirect costs, and anticipated profit. A Materially Unbalanced Bid is when the LPA determines that an award to the Bidder submitting a Mathematically Unbalanced Bid will not result in the lowest ultimate cost to the LPA.

102.09 Proposal Guaranty. The LPA will reject a Bid submitted without a Proposal Guaranty in the amount designated and payable to the PRC. Submit the required Proposal Guaranty in one of the following forms:

- A. ~~Properly executed project Bid bond submitted on the LPA's form.~~
- B. ~~Properly executed electronic bid transfer to the LPA's account.~~
- C. ~~Certified check drawn on the account of the Bidder submitting the Bid.~~
- D. ~~Cashier's check.~~
- E. ~~Properly executed electronic project Bid bond submitted using the software as specified in the Bid Documents.~~

~~When submitting a Bid bond, ensure that the Surety is licensed to do business in the State.~~

~~If the LPA invites alternate Bids and the Bidder elects to Bid more than one alternate, the Bidder may submit one Proposal Guaranty in the amount required for a single alternate. The Proposal Guaranty covers each individual Bid. See Bid Documents in contract for acceptable forms.~~

102.10 Delivery of Bid.

~~LPA SHALL SPECIFY~~ [See bid documents for requirements.](#)

102.11 Withdrawal of Bids.

[After bids are opened, ORC 5525.01 requires that a bidder identify a mistake in its bid within 48 hours of the bid opening. After bids are opened the bidder must provide a written request to withdraw a bid already filed with the department. An bidder for whom a request to withdraw its bid is approved by the department will not be permitted to participate in any manner in a contract awarded for that project for which the bid was withdrawn.](#)

~~LPA SHALL SPECIFY~~

102.12 Combination Proposals. The LPA may elect to issue Bid Documents for projects in combination or separately, so that Bids may be submitted either on the combination or on separate units of the combination. The LPA reserves the right to make awards on combination Bids or separate Bids to the best advantage of the LPA. The LPA will not consider combination Bids, other than those it specifically identifies in the Bid Documents. The LPA will write separate Contracts for each individual Project included in the combination.

102.13 Public Opening of Bids. The LPA will publicly open Bids at the time and place indicated in the notice to Contractors. The LPA will announce the total Bid amount for each Bid.

Bidders or their authorized agent and other interested persons are invited to the opening.

The LPA may postpone the receipt of Bid time or the opening of Bids time. If the LPA changes the hour or the date of the receipt of Bids or the opening of Bids, it will issue an addendum or public notice to notify prospective Bidders.

102.14 Disqualification of Bidders.

~~LPA SHALL SPECIFY~~ [See bid documents for requirements.](#)

102.15 Material Guaranty. Before any Contract is awarded, the LPA may require the Bidder to furnish a complete statement of the origin, composition, and manufacture of any or all Materials to be used in the construction of the Work together with samples. The LPA may test the samples as specified in these Specifications to determine their quality and fitness for the Work.

102.16 Certificate of Compliance with Affirmative Action Programs. Before any Contract is awarded, the LPA will require the Bidder to furnish a valid Certificate of Compliance with Affirmative Action Programs, issued by the [State EEO Coordinator](#).

102.17 Drug-Free Safety Program. During the life of this project, the Contractor and all its Subcontractors, that provide labor on the Project site, must be enrolled in and remain in good standing in the [Ohio Bureau of Worker's Compensation](#) ("OBWC") [Drug-Free Safety Program](#) ("DFSP") or a comparable program approved by the OBWC.

In addition to being enrolled in and in good standing in an OBWC-approved DFSP or a comparable program approved by the OBWC, the LPA requires each Contractor and Subcontractor that provides labor, to subject its employees who perform labor on the project site to random drug testing of 5 percent of its employees. The random drug testing percentage must also include the on-site supervisors of the Contractors and Subcontractors. Upon request, the Contractor and Subcontractor shall provide evidence of required testing to the LPA.

Each Subcontractor shall require all lower-tier Subcontractors that provides labor on the project site with whom the Subcontractor is in contract for the Work to be enrolled in and be in good standing in the OBWC-approved DFSP prior to a lower-tier Subcontractor providing labor at the Site.

The LPA will declare a bid non-responsive and ineligible for award if the Contractor is not enrolled and in good standing in the [Ohio Bureau of Workers' Compensation's Drug-Free Safety Program \(DFSP\) Discount Program](#) or a similar program approved by the Bureau of Workers' Compensation within 8 days of the bid opening. Furthermore, the LPA will deny all requests to sublet when the subcontractor does not comply with the provisions of this section.

Failure of the Contractor to require a Subcontractor to be enrolled in and be in good standing in the an OBWC-approved DFSP prior to the time that the Subcontractor provides labor at the Site, shall result in the Contractor being found in breach of the Contract and that breach shall be used in the responsibility analysis of that Contractor or the Subcontractor who was not enrolled in a program for future contracts with the State for five years after the date of the breach.

103 AWARD AND EXECUTION OF CONTRACT

103.01 Consideration of Proposals. After opening and announcing the Bids, the LPA will compare the Bidders' proposed prices. The proposed price is the summation of the products of the estimated quantities shown in the Proposal and the unit Bid prices. If the amount shown for the proposed product differs from the actual product of the unit Bid price and the estimated quantity, then the actual product will govern.

The LPA may reject any or all Bids, waive technicalities, or advertise for new Bids without liability to the LPA.

103.02 Award of Contract.

[See bid documents for requirements.](#)

LPA SHALL SPECIFY

103.03 Cancellation of Award. The LPA may cancel a Contract award at any time before all parties sign the Contract without liability to the LPA.

103.04 Return of Proposal Guaranty. Immediately after the opening and checking of Bids, the LPA will return all Proposal Guaranties provided in the form of a certified check or cashier's check, except to the three lowest Bidders. Within 10 days after opening bids, the LPA will return the Proposal Guaranties of the two remaining unsuccessful Bidders. After the successful Bidder submits the signed Contract, Contract Bonds, and other Contract Documents, and after the LPA signs the Contract, the LPA will return the Proposal Guaranty to the successful Bidder. The LPA will not return Bid bonds.

103.05 Requirement of Contract Bond. The contractor shall furnish a performance and payment bond in an amount at least equal to 100 percent of the estimate as security for the faithful performance of its contract. In addition to the project Owner, ODOT shall be named as an obligee. Furnish Contract Bonds within 10 days after receiving notice of award.

103.06 Execution of Contract.

[See bid documents for requirements.](#)

LPA SHALL SPECIFY

103.07 Failure to Execute Contract. If the successful Bidder fails to sign the Contract and furnish the Contract Bonds, the LPA will have just cause to cancel the award. The LPA may award the Contract to the next lowest responsive Bidder, re-advertise the Work, or take any other action decided by the PRC and/or CPE.

104 SCOPE OF WORK

104.01 Intent of the Contract Documents. The intent of the Contract Documents is to provide for the construction and completion of the Work. Perform the Work according to the Contract Documents.

104.02 Revisions to the Contract Documents.

A. General. The LPA reserves the right to revise the Contract Documents at any time. Such revisions do not invalidate the Contract or release the Surety, and the Contractor agrees to perform the Work as revised.

The provisions of this section are subject to the limitation of the ORC.

B. Differing Site Conditions. During the progress of the Work, if subsurface or latent physical conditions are encountered at the site differing materially from those indicated in the Contract Documents or if unknown physical conditions of an unusual nature, differing materially from those ordinarily encountered and generally recognized as inherent in the Work provided for in the Contract Documents, are encountered at the site, notify the Engineer as specified in [108.02.F](#) of the specific differing conditions before they are disturbed or the affected Work is performed.

Upon notification, the Engineer will investigate the conditions and if it is determined that the conditions materially differ and cause an increase or decrease in the cost or time required for the performance of any Work under the Contract, the LPA will make an adjustment and modify the Contract as specified in [108.06](#) and [109.05](#). The Engineer will notify the Contractor of the determination whether or not an adjustment of the Contract is warranted.

C. Suspension of Work. If the performance of all or any portion of the Work is suspended or delayed by the Engineer in writing for an unreasonable period of time (not originally anticipated, customary, or inherent to the construction industry) and the Contractor believes that additional compensation or time is due as a result of such suspension or delay, notify the Engineer as specified in [108.02](#).

Upon receipt of notice, the Engineer will evaluate the Contractor's request. If the Engineer agrees that the cost or time required for the performance of the Work has increased as a result of such suspension and the suspension was caused by conditions beyond the control of and not the fault of the Contractor, its suppliers, or subcontractors at any approved tier, and not caused by weather, the Engineer will make an equitable adjustment (excluding profit) and modify the contract as specified in [108.06](#) and [109.05](#). The Engineer will notify the Contractor of its determination whether or not an adjustment to the Contract Documents is warranted. Failure of the Engineer to suspend or delay the Work in writing does not bar the Contractor from receiving a time extension or added compensation according to [108.06](#) and [109.05](#).

The LPA will not make an adjustment under this subsection in the event that performance is suspended or delayed by any other cause, or for which an adjustment is provided or excluded under any other term or condition of this Contract.

D. Significant Changes in Character of the Work. The Engineer may increase or decrease quantities and alter the Work as necessary to complete the Project. The Engineer will make appropriate adjustments according to [108.06](#) and [109.05](#), if such alterations significantly change the character of the Work.

If the Contractor disagrees as to whether an alteration constitutes a significant change, use the notification procedures specified in [108.02.G](#).

The term "significant change" is defined as follows:

1. when the character of the Work as altered differs materially in kind or nature from that involved or included in the original proposed construction; or
2. when the product of the quantity in excess of the estimated quantity of a contract item and the unit price exceeds the limits set forth in Table [104.02-1](#).

TABLE 104.02-1

Contract Price	Contract Limits
Up to \$500,000	\$25,000
\$500,001 to \$2,000,000	5% of Total Contract Price
Over \$2,000,000	\$100,000

A quantity underrun is defined as follows:

- a. the estimated quantity of a contract item exceeds four units, and
- b. the decrease in quantity of any unit price Contract Item exceeds 25 percent of the estimated quantity, and
- c. the total of all such adjustments for all Contract Items is more than \$400.

Then after the determination of final quantities according to [109.12.C](#), the Engineer will adjust the unit prices for the affected Contract item by multiplying the bid unit price by the factor obtained from Table [104.02-2](#).

TABLE 104.02-2

% Decrease	Factor	% Decrease	Factor
25	1.08	57	1.33
26 to 27	1.09	58	1.35
28 to 29	1.10	59	1.36
30 to 31	1.11	60	1.38
32 to 33	1.12	61	1.39
34 to 35	1.13	62	1.41
36	1.14	63	1.43
37 to 38	1.15	64	1.44
39	1.16	65	1.46
40 to 41	1.17	66	1.49
42	1.18	67	1.51
43	1.19	68	1.53
44 to 45	1.20	69	1.56
46	1.21	70	1.58
47	1.22	71	1.61
48	1.23	72	1.64
49	1.24	73	1.68
50	1.25	74	1.71
51	1.26	75	1.75
52	1.27	76	1.79
53	1.28	77	1.84
54	1.29	78	1.89
55	1.31	79	1.94
56	1.32	80 and over	2.00

When the increase in quantity or decrease in quantity of any unit price contract item does not exceed the limits set forth in Tables [104.02-1](#) and [104.02-2](#), the change is considered a minor change. The Department will pay for minor changes in the Work at the unit bid price.

In place of 104.02(D) above, the LPA has the option to use the following language from 23 CFR 635.109(a)(3)

Significant changes in the character of work.

- ~~(i) The engineer reserves the right to make, in writing, at any time during the work, such changes in quantities and such alterations in the work as are necessary to satisfactorily complete the project. Such changes in quantities and alterations shall not invalidate the contract nor release the surety, and the contractor agrees to perform the work as altered.~~
- ~~(ii) If the alterations or changes in quantities significantly change the character of the work under the contract, whether such alterations or changes are in themselves significant changes to the character of the work or by affecting other work cause such other work to become significantly different in character, an adjustment, excluding anticipated profit, will be made to the contract. The basis for the adjustment shall be agreed upon prior to the performance of the work. If a basis cannot be agreed upon, then an adjustment will be made either for or against the contractor in such amount as the engineer may determine to be fair and equitable.~~
- ~~(iii) If the alterations or changes in quantities do not significantly change the character of the work to be performed under the contract, the altered work will be paid for as provided elsewhere in the contract.~~
- ~~(iv) The term “significant change” shall be construed to apply only to the following circumstances:
 - ~~(A) When the character of the work as altered differs materially in kind or nature from that involved or included in the original proposed construction; or~~
 - ~~(B) When a major item of work, as defined elsewhere in the contract, is increased in excess of 125 percent or decreased below 75 percent of the original contract quantity. Any allowance for an increase in quantity shall apply only to that portion in excess of 125 percent of original contract item quantity, or in case of a decrease below 75 percent, to the actual amount of work performed.~~~~

E. Eliminated Items. The LPA may partially or completely eliminate contract items.

The LPA will only make an adjustment to compensate the Contractor for the reasonable cost incurred in preparation to perform significantly changed work as set forth in [104.02.D](#) or work completely eliminated prior to the date of the Engineer’s written order to significantly change or completely eliminate the Work. The adjustment will be determined according to [109.04](#) and [109.05](#). Such payment will not exceed the price of the Contract Item.

The LPA will not seek a savings for maintaining traffic, mobilization, and construction layout stakes items for Eliminated Items of Work, unless there is a significant change.

F. Extra Work. Perform Extra Work as directed by the Engineer. The LPA will pay for Extra Work as specified in [109.05](#). Time extensions, if warranted, will be determined according to [108.06](#).

G. Unilateral Authority to Pay. The LPA has unilateral authority to pay the Contractor sums it determines to be due to the Contractor for work performed on the project. This unilateral authority to pay by the LPA does not preclude or limit the rights of the LPA and the Contractor to negotiate and agree to the amounts to be paid to the Contractor.

104.03 Rights in and Use of Materials Found on the Work. Upon obtaining the Engineer’s approval, the Contractor may use material, such as stone, gravel, or sand, found in the plan excavation for another Contract Item. The LPA will pay for both the excavation of the material under the corresponding Contract Item and for the placement of the excavated material under the Contract Item(s)

for which the excavated material is used. Excavate or remove material only from within the grading limits, as indicated by the slope and grade lines.

Obtain written permission from the Engineer according to [107.11.A](#).

104.04 Cleaning Up. Maintain the Project in a presentable condition. Remove all rubbish, layout stakes, sediment control devices as directed by the Engineer, excess material, temporary structures, and equipment, including stream channels and banks within the Right-of-Way at drainage structures, and all borrow and waste areas, storage sites, temporary plant sites, haul roads, and other ground occupied by the Contractor in connection with the Work. Establish suitable vegetative cover in these areas by seeding and mulching according to Item [659](#), except for cultivated fields. Leave the Project site in an acceptable condition as determined by the Engineer. The cost of cleanup is incidental to all contract items. The LPA may withhold 10 percent of the Bid amount for the mobilization contract item, if included, until performance under this section is complete. See [624.04](#).

105 CONTROL OF WORK

105.01 Authority of the Engineer. The Engineer will decide questions concerning all of the following:

- A. The quality and acceptability of Materials furnished.
- B. The quantity of Work performed.
- C. The Contractor's rate of progress.
- D. The interpretation of the Contract Documents.
- E. Acceptable fulfillment of the Contract.
- F. Contractor compensation.

The Engineer may suspend all or part of the Work when the Contractor fails to correct conditions that are unsafe for the workers or the general public, fails to comply with the Contract Documents, or fails to comply with the Engineer's orders. The Engineer may suspend the Work due to adverse weather conditions, conditions considered adverse to the prosecution of the Work, or other conditions or reasons in the public interest.

The Engineer's acceptance does not constitute a waiver of the LPA's right to pursue any and all legal remedies for defective work or work performed by the Contractor in an un-workmanlike manner.

105.02 Plans and Working Drawings. The Plans show details of structures, the lines and grades, typical cross-sections of the Roadway, and the location and design of structures. Keep at least one set of Plans at the Project at all times.

Prepare working drawings when required by the Contract Documents and after verifying applicable field and plan elevations, dimensions, and geometries. Where Work consists of repairs, extension, or alteration of existing structures, take measurements of existing structures to accurately join old and new Work.

Unless otherwise indicated, the LPA will review working drawing submittals to ensure conformance with the Contract and to provide the Contractor a written response to document the results of its review as follows:

- A. **"ACCEPTED."** The LPA accepts the submittal for construction, fabrication, or manufacture.
- B. **"ACCEPTED AS NOTED."** The LPA accepts the submittal for construction, fabrication, or manufacture, subject to the Contractor's compliance with all LPA comments or corrections to the submittal. If also marked "RESUBMIT," the LPA still accepts the submittal, but requires the Contractor to provide a corrected submittal to the LPA.
- C. **"NOT ACCEPTED."** The LPA does not accept the submittal. The submittal does not conform to Contract requirements. Do not begin construction, fabrication, or manufacture of Work included in the submittal. Revise the submittal to comply with LPA comments or corrections and Contract requirements and provide the revised submittal to the LPA for another review.

"Accepted" and "Accepted as Noted" Working Drawings are Contract Documents as defined in [101.03](#). The LPA's acceptance will not relieve the Contractor of responsibility to complete the Work according to the Contract nor relieve a signatory engineer's responsibility as defined by [OAC 4733-23](#). Include the cost of furnishing Working Drawings in the cost of the Work they cover.

105.03 Conformity with Contract Documents. Perform all Work and furnish all Materials in reasonably close conformity with the lines, grades, cross-sections, dimensions, and material requirements as shown on the Plans and as specified.

If the PRC and/or CPE determines the Work is not in reasonably close conformity with the Contract Documents and determines the Contractor produced reasonably acceptable Work, the PRC and/or CPE may accept the Work based on engineering judgment. The PRC and/or CPE will document the basis of acceptance in a Change Order that provides for an appropriate adjustment to the Contract Price of the accepted Work or Materials. If the PRC and/or CPE determines the Work is not in reasonably close conformity with the Contract Documents and determines the Work is inferior or unsatisfactory, remove, replace, or otherwise correct the Work at no expense to the LPA.

105.04 Coordination of the Contract Documents. The Contract Documents are those defined in [101.03](#). A requirement appearing in one of these documents is as binding as though it occurs in all. The Engineer will resolve discrepancies using the following descending order of precedence:

- A. Addenda.
- B. Proposal and Special Provisions.
- C. Plans.
- D. [Supplemental Specifications](#).
- E. Standard Construction Drawings.
- F. Standard Specifications.

Immediately notify the Engineer upon discovering any latent error or omission in the Contract Documents.

105.05 Cooperation by Contractor.

LPA SHALL SPECIFY [Omitted – See contract documents](#)

105.06 Superintendent. Provide a Superintendent for the Project that is available and responsive at all times and is responsible for all aspects of the Work, irrespective of the amount of subcontract Work. The Superintendent must be capable of reading and understanding the Contract Documents and experienced in the type of Work being performed. The Superintendent shall receive instructions from the Engineer or the Engineer's authorized representatives. The Superintendent shall promptly execute the Engineer's orders or directions and promptly supply the required materials, equipment, tools, labor, and incidentals.

105.07 Cooperation with Utilities. Unless otherwise provided for by the Contract Documents, the LPA will direct the utility owners to relocate or adjust water lines, gas lines, wire lines, service connections, water and gas meter boxes, water and gas valve boxes, light standards, cableways, signals, and all other utility appurtenances within the limits of the proposed construction at no cost to the Contractor.

If the Contractor is directed by a utility company to perform any work not specifically contained in this note, the LPA will not compensate the Contractor for this work unless the LPA approves the request in writing before the work begins. If the work is not preapproved by the LPA, the Contractor will be responsible for obtaining reimbursement for its work from the utility company which directed the Contractor to perform the work.

In the event that the Contractor requests that additional work, not specifically contained in this note, be performed by a utility company, the Contractor will be responsible for reimbursing the utility

company for the additional work unless the LPA has agreed in writing to pay for the additional work before the work begins.

The Contract Documents will indicate various utility items and indicate a time frame or date when the LPA expects the owners to complete utility relocation or adjustment. Provide utility owners adjusting facilities during construction with adequate notification of the scheduled Work to prevent conflict with the Contractor's schedule of operations.

When bidding, consider all permanent and temporary utility appurtenances in present and relocated positions as shown in the Contract Documents.

According to [ORC 153.64](#) and at least 2 Workdays prior to commencing construction operations in an area that may affect underground utilities shown on the Plans, notify the Engineer, the registered utility protection service, and the owners that are not members of the registered utility protection service.

The owner of the underground utility shall, within 48 hours, excluding Saturdays, Sundays, and legal holidays, after notice is received, start staking, marking, or otherwise designating the location, course, ± 2 feet (± 0.6 m), together with the approximate depth of the underground utilities in the construction area.

If the utility owners fail to relocate or adjust utilities as provided for in the Contract Documents and the Contractor sustains losses that could not have been avoided by the judicious handling of forces, equipment, and plant, or by reasonable revisions to the schedule of operations, then the Engineer will adjust the Contract according to [108.06](#) and [109.05](#).

105.08 Cooperation Between Contractors. At any time, the LPA may contract for other work on or near the Project.

Separate Contractors working within the limits of the Project shall conduct their work without interfering with or hindering the progress or completion of Work being performed by other Contractors and shall cooperate with each other as directed by the Engineer.

105.09 Authority and Duties of the Inspector. Inspectors are authorized to inspect the Work and the preparation, fabrication, or manufacture of materials. Inspectors are not authorized to alter or waive requirements of the Contract Documents. Inspectors are authorized to notify the Contractor of Work that does not conform to the Contract; reject materials that do not conform to Specification requirements; and until the issue is decided by the Engineer, suspend portions of the Work if there is a question regarding the Contract Documents, use of unapproved material, or safety. Inspectors are not obligated or authorized to provide direction, superintendence, or guidance to the Contractor, its crew, its subcontractors, or suppliers to accomplish the Work.

Any action or inaction of the Inspector does not constitute a waiver of the LPA's right to pursue any and all legal remedies for defective work or work performed by the Contractor in an un-workmanlike manner.

105.10 Inspection of Work. The Engineer may inspect materials and the Work. Provide the Engineer or the Engineer's representative access to the Work, information, and assistance necessary to conduct a complete inspection. Notify the Engineer at least 24 hours prior to all required inspections.

When directed by the Engineer, remove or uncover completed Work to allow inspection. After the Engineer's inspection, restore the Work according to the requirements of the Contract Documents. If the inspected Work conformed to the requirements of the Contract Documents, the LPA will pay for uncovering or removing and restoring the Work as Extra Work according to [109.05](#). If the inspected

Work did not conform to the Contract Documents, the LPA will not pay for uncovering or removing and restoring the Work.

The LPA shall have the discretion to dictate the level of inspection for any item of work. The Contractor bears sole responsibility for the quality of work and compliance with the contract regardless of the LPA's level of inspection.

The LPA's failure to identify defective Work or material shall not, in any way, prevent later rejection when defective Work or material is discovered, or obligate the LPA to grant acceptance under [109.11](#) or [109.12](#).

Inspection of Work may include inspection by representatives of other government agencies or railroad corporations that pay a portion of the cost of the Work. This inspection will not make other government agencies or railroad corporations a party to the Contract and will not interfere with the rights of the Contractor or LPA.

105.11 Removal of Defective and Unauthorized Work. Work that does not conform to the requirements of the Contract is defective.

Unless the LPA formally accepts defective Work according to [105.03](#), immediately remove and replace defective Work.

Unauthorized Work is Work done contrary to the instructions of the Engineer, beyond the plan lines, or any extra work done without the LPA's permission. The LPA will not pay for unauthorized Work. The Engineer may order the Contractor to remove or replace unauthorized Work at no expense to the LPA.

If the Contractor fails to comply with the Engineer's orders under the provisions of this subsection, the PRC and/or CPE may correct or remove and replace defective or unauthorized Work and deduct the costs from the Contract Price.

105.12 Load Restrictions. Comply with all legal load restrictions when hauling materials on public roads.

Operate equipment of a weight or so loaded as to not cause damage to structures, to the roadway, or to other types of construction. Comply with subsection [501.05.B.6](#) for allowed loads on bridges.

Do not use off road vehicles on bases or pavements unless permitted by the PRC and/or CPE in writing.

Do not haul on concrete pavement, base, or structures before the expiration of the curing period.

Do not exceed the legal load limits in this section unless permitted by the PRC and / or CPE in writing.

105.13 Haul Roads. Prior to hauling equipment or materials, provide written notification to the Engineer of the specific roads or streets on the haul route. If the haul route includes roads and streets that are not under the jurisdiction and control of the LPA and the PRC determines that LPA controlled roads are not available or practical for a haul route, the Contractor may use local roads and streets that are not restricted by local authorities. If the PRC determines that LPA controlled roads are available and practical for a haul route, revise the proposed haul route provided in the original written notification and resubmit to the PRC.

If the Engineer determines that haul route roads were properly used during construction to haul equipment and materials and that the haul route roads were damaged, then the Engineer may order the Contractor to perform immediate and practical repairs to ensure reasonably normal traveling conditions. The Engineer will pay for repairs according to applicable provisions of [109.04](#) and [109.05](#).

The Contractor shall not file a claim for delays or other impacts to the Work caused by disputes with the local authorities regarding the use of local roads or streets as haul routes. The Contractor shall save the LPA harmless for any closures or hauling restrictions outside the Project limits beyond the control of the LPA.

105.14 Maintenance During Construction. Maintain the Work during construction and until Final Inspector accepts the work under [109.12](#), except for portions of the Work accepted under [109.11](#). The Contractor is responsible for damage done by its equipment.

Maintain the previous courses or subgrade during all construction operations, when placing a course upon other courses of embankment, base, subgrade, concrete or asphalt pavement, or other similar items previously constructed. This maintenance includes, but is not limited to draining, re-compacting, re-grading, or if destroyed, the removal of Work previously accepted by the LPA.

Maintain the Post Construction Storm Water Best Management Practice (BMP) features. Prevent sediment laden surface water from coming in contact with the BMP features during construction.

Maintain the Work during construction and before acceptance of the Work under [109.12](#), except for portions of the Work accepted under [109.11](#). The LPA will not provide additional compensation for maintenance work.

105.15 Failure to Maintain Roadway or Structure. If the Contractor, at any time, fails to comply with the provisions of [105.14](#), the Engineer will immediately notify the Contractor of such noncompliance. If the Contractor fails to remedy unsatisfactory maintenance within 24 hours after receipt of such notice, the Engineer may immediately proceed to maintain the Project, and deduct the entire cost of this maintenance from monies due or to become due the Contractor on the Contract.

105.16 Borrow and Waste Areas. Prior to beginning borrow or wasting operations, obtain the Engineer's written approval of a detailed operation plan that addresses the following concerns:

- A. Control of drainage water.
- B. Cleanup, shaping, and restoration of disturbed areas.
- C. Disposal of regulated materials.
- D. Avoidance of regulated areas.
- E. Excavation and filling of waste and borrow areas.
- F. Saving of topsoil.
- G. Temporary Sediment and Erosion Control BMPs required for compliance under the [Clean Water Act](#), [Ohio Water Pollution Control Act, \(OWPCA\) \(ORC Chapter 6111\)](#) and the [NPDES permit](#).

Perform all engineering necessary to ensure long term stability of all side slopes and foundations of all borrow and waste areas. Furnish a certification by a [Registered Engineer](#) attesting to the stability of all borrow and waste areas. All damage resulting from the instability of borrow and waste areas, the removal of borrow materials, the placement of waste materials, or the hauling of material to and from these areas is the sole responsibility of the Contractor. Repairs to approved haul roads will be made in accordance with [105.13](#).

Perform all engineering, including any field investigation, necessary to ensure long term stability of all side slopes and foundations of all borrow and waste areas.

Ensure that all side slopes of all waste areas do not reduce horizontal sight distance as defined by the current version of the [Department's Location and Design Manual](#).

Have the proposed borrow and waste areas reviewed by an environmental consultant that is pre-qualified by the Department for ecological work. Have the environmental consultant certify that the proposed borrow and waste operations will not impact the “Waters of the United States” or an isolated wetland. If consultant certification is not provided, obtain the 404/401 permits necessary to perform the operations as proposed. Have the environmental consultant certify that the work conforms to the requirements of the permit(s). Provide all documentation submitted to obtain the appropriate permit(s) and a copy of the permit(s) to the District’s [Office of Environmental Services](#).

If burning is permitted under the [OAC-3745-19](#) and [ORC 1503.18](#), submit a copy of the [Ohio EPA](#) permit and the [Ohio DNR](#) permit to the Engineer and copies of all information used to obtain the permit.

Prior to the disposal of waste materials, submit to the LPA an executed copy of the Contract or permission statement from the property owner. The Contract or permission statement must indicate that the waste materials are not the property of the LPA. Further, it must expressly state that the LPA is not a party to the Contract or permission statement and that the Contractor and property owner will hold the LPA harmless from claims that may arise from their contract or permission statement.

Restoration of all borrow or waste areas includes cleanup, shaping, replacement of topsoil, and establishment of vegetative cover by seeding and mulching according to [104.04](#) and Item [659](#). Ensure the restored area is well drained unless approval is given by the Engineer to convert a pit area into a pond or lake, in which case confine restoration measures to the disturbed areas above the anticipated normal water level.

For waste sites shown on the plan, the plan will indicate if the clearances have or have not been obtained for the project right-of-way locations. No extension of time or additional compensation will be paid for any delays due to not having the written permit(s) to waste in a floodplain.

The allowed use of Project Right-of-Way and other LPA property for borrow and waste is detailed in [104.03](#) and [107.11](#).

Borrow and Waste Area shall adhere to [107.10](#).

The cost of work described herein is incidental to the Contract, unless included under another item of work.

105.17 Construction and Demolition Debris. [OAC-3745-37](#), [OAC-3745-400](#), and [ORC Chapter 3714](#) regulates the use and disposal of construction and demolition debris. Notify the local Board of Health or the local [Ohio EPA](#) office 7 days before placing Clean Hard Fill off the Right-of-Way. Submit copies of this notification to the Engineer.

Legally dispose of debris containing wood, road metal, or plaster at a licensed construction and demolition debris site.

Under the regulations cited above the disposal of brush, trees, stumps, tree trimmings, branches, weeds, leaves, grass, shrubbery, yard trimmings, crop residue, and other plant matter is restricted. If allowed by the Contract Documents, the Contractor may waste brush, trees, stumps, tree trimming, branches, weeds, leaves, grass, shrubbery, yard trimmings, crop residue, and other plant matter within the Right-of-Way. Otherwise, submit a plan and any required permits to legally dispose of these materials off the Right-of-Way to the Engineer. Provide all documents submitted to obtain this permit to the Engineer.

If the Project contains garbage or solid and hazardous waste, the Contract Documents will detail the removal of these items.

When wasting PCC, mix the PCC with at least 30 percent natural soil to construct an inner core in the waste area. Cover this inner core with 3 feet (1.0 m) of natural soil on the top and 8 feet (2.4 m) on

the side slopes. Place and compact the material according to [203.06.D](#) to prevent future settlement and sliding.

Clean Hard Fill consisting of reinforced or non-reinforced concrete, asphalt concrete, brick, block, tile or stone that is free of all steel as per [703.16](#) shall be managed in one or more of the following ways:

- A. Recycled into a usable construction material.
- B. Disposed in licensed construction and demolition debris facility.
- C. Used in legitimate fill operations on the site of generation according to [105.16](#).
- D. Used in legitimate fill operations on a site other than the site of generation to bring a site up to grade.

A Beneficial Reuse Certification form needs to be properly executed by the Recipient prior to any material leaving the project.

105.18 Acceptance. The LPA will accept Work according to [109.12](#) or completed sections of the Project according to [109.11](#).

105.19 Value Engineering Change Proposals. Value Engineering Change Proposals are not permitted in this Contract.

106 CONTROL OF MATERIAL

106.01 Source of Supply and Quality Requirements. Notify the Engineer of the proposed sources of supply before the delivery of materials. The Engineer may approve materials at the source of supply before delivery. If the proposed sources of supply cannot produce the specified material, then furnish materials from alternate sources without adjustment to the Contract Price or Completion Date.

106.02 Samples, Tests, and Cited Specifications. The Engineer will inspect and determine whether the materials comply with the specified requirements before they are incorporated into the Work. The LPA may sample and test materials or require certifications. Unless specified, the LPA will pay for and test materials according to [AASHTO](#), [ASTM](#), or the methods on file in the office of the Engineer. A qualified representative of the LPA will take test samples according to LPA procedures. Read any reference to other specifications or testing methods to mean the version in effect at the pertinent Project Advertisement date. All materials being used are subject to inspection, test, or rejection at any time before their incorporation into the Work. The LPA will furnish copies of the tests to the Contractor's representative upon request. Furnish the required samples and specified material certifications at no expense to the LPA other than provided in [109.03](#).

Equip all transports and distributors hauling asphalt material with an approved submerged asphalt material sampling device.

106.03 Small Quantities and Materials for Temporary Application. The Engineer may accept small quantities and materials for temporary application that are not intended for permanent incorporation in the Work. The Engineer may accept these small quantities and materials for temporary application in either of the following cases:

- A. Where similar materials from the same source have recently been approved.
- B. Where the materials, in the judgment of the Engineer, will serve the intended purpose.

106.04 Plant Sampling and Testing Plan. The Engineer may undertake the inspection of materials at the source.

In the event plant sampling and testing is undertaken, the Contractor and its material provider shall meet the following conditions:

- A. Cooperate and assist the Engineer with the inspection of materials. Provide full entry to the Engineer at all times to such parts of the plant as may concern the manufacture or production of the materials being furnished. Agree to all documentation and inspection requirements of the [TE-24 plant sampling and testing plan](#).
- B. If required by the Engineer, arrange for the inspector to use an approved building on site. The building should be located near the plant and independent of any building used by the material producer.
- C. Maintain and provide adequate safety measures at the plant at all times.

The LPA reserves the right to retest all materials that have been tested and accepted at the source of supply before their incorporation into the Work. After the approved materials have been delivered to the site, the LPA may reject all materials that when retested do not meet the requirements of the Contract Documents.

106.05 Storage of Materials. Properly store all materials to ensure the preservation of their quality and fitness for the Work. The Engineer may re-inspect stored materials before their incorporation into the Work, even though they were approved before storage. Locate stored materials

to facilitate their prompt inspection. The Contractor may use approved portions of the Project Right-of-Way for storage; however, if any additional space is required, the Contractor must provide it at the Contractor's expense. Do not use private property for storage purposes without written permission from the owner or lessee. If requested by the Engineer, furnish copies of the written permission. Restore all storage sites to their original condition at no expense to the LPA. The Contractor and property owner will hold the LPA harmless from claims that may arise from their contract or permission statement. This subsection does not apply to the stripping and storing of topsoil, or to other materials salvaged from the Work.

Areas used to Store Materials shall conform to [107.10](#).

106.06 Handling Materials. Handle all materials in such manner as to preserve their quality and fitness for the Work. Transport aggregates from the storage site to the project site in vehicles constructed to prevent loss or segregation of materials after loading and measuring. Ensure that there are no inconsistencies in the quantities of materials loaded for delivery and the quantities actually received at the place of operations.

106.07 Unacceptable Materials. Unacceptable materials are all materials not conforming to the requirements of these Specifications at the time they are used. Immediately remove all unacceptable materials from the project site unless otherwise instructed by the PRC and/or CPE. The PRC and/or CPE will determine if unacceptable materials may remain conforming to [Supplement 1102](#). The PRC and/or CPE must approve the use of previously identified unacceptable materials that have been corrected or repaired. If the Contractor fails to comply immediately with any order of the PRC and/or CPE made under the provisions of this subsection, the PRC and/or CPE will have authority to remove and replace defective materials and to deduct the cost of removal and replacement from any monies due or to become due to the Contractor.

106.08 LPA-Furnished Material. Furnish all materials required to complete the Work, except when otherwise provided in the Proposal.

The LPA will deliver the LPA-furnished materials to the Contractor at the points specified in the Contract Documents.

Include the cost of handling and placing of all LPA-furnished materials in the contract price for the contract item for which they are used.

The LPA will hold the Contractor responsible for all material upon delivery of the materials to the Project site. The LPA will make deductions from any monies due the Contractor to make good any shortages and deficiencies, for any cause whatsoever, and for any damage that may occur after such delivery, and for any demurrage charges.

106.09 Steel and Iron Products Made in the United States. Furnish steel and iron products that are made in the United States according to the applicable provisions of Federal regulations stated in [23 CFR 635.410](#) and State of Ohio laws, and [ORC 153.011](#) and [5525.21](#). "United States" means the United States of America and includes all territory, continental or insular, subject to the jurisdiction of the United States.

A. Federal Requirements. All steel or iron products incorporated permanently into the Work must be made of steel or iron produced in the United States and all subsequent manufacturing must be performed in the United States. Manufacturing is any process that modifies the chemical content; physical shape or size; or final finish of a product. Manufacturing begins with the initial melting and mixing, and continues through the bending and coating stages. If a domestic product is taken out of the United States for any process, it becomes a foreign source material.

B. State Requirements. All steel products used in the Work for load-bearing structural purposes must be made from steel produced in the United States. State requirements do not apply to iron.

C. Applications.

1. When the Work is federally funded both the Federal and State requirements apply. This includes all portions of the Work, including portions that are not federally funded.

2. When the Work has no Federal funds, only the State requirements apply.

D. Exceptions. ODOT may grant specific written permission to use foreign steel or iron products in bridge construction and foreign iron products in any type of construction. The ODOT may grant such exceptions under either of the following conditions:

1. The cost of products to be used does not exceed 0.1 percent of the total Contract cost, or \$2,500, whichever is greater. The cost is the value of the product as delivered to the project.

2. The specified products are not produced in the United States in sufficient quantity or otherwise are not reasonably available to meet the requirements of the Contract Documents. The ODOT may require the Contractor to obtain letters from three different suppliers documenting the unavailability of a product from a domestic source, if the shortage is not previously established.

E. Proof of Domestic Origin. Furnish documentation to the Engineer showing the domestic origin of all steel and iron products covered by this section, before they are incorporated into the Work. Products without a traceable domestic origin will be treated as a non-domestic product.

106.10 Qualified Products List. The LPA may use [Qualified Product Lists \(QPL\)](#) for approval of manufactured materials. The [Office of Materials Management \(OMM\)](#) will maintain the [QPL](#) and the standard procedure for the [QPL](#) process. Inclusion of a material onto the [QPL](#) will be determined by [OMM](#) with support from other Department offices. To be kept on the [QPL](#), manufacturers must recertify their material according to the Department's standard procedure by January 1 of each year. When a material requires [QPL](#) acceptance, only provide materials listed on the [QPL](#) at the time of delivery of the material to the project. Provide the Engineer documentation according to the Department's standard procedure that, at the time of delivery, the material provided is on the [QPL](#).

106.11 Maritime Transportation. On federal-aid projects, ensure that project-specific materials or equipment transported by ocean vessel are in compliance with [46 CFR 381](#) and the [Cargo Preference Act](#). Transport at least 50% of any equipment or materials on privately owned United States-flag commercial vessels, if available.

107 LEGAL RELATIONS AND RESPONSIBILITY TO PUBLIC

107.01 Laws to be Observed. Stay fully informed of all Federal and State laws, all local laws, ordinances, and regulations, and all orders and decrees of authorities having any jurisdiction or authority that affect those engaged or employed on the Work, or that affect the conduct of the Work. Observe and comply with all such laws, ordinances, regulations, orders, and decrees. The Contractor shall protect and indemnify the State, respective Local and its representatives against any claim or liability arising from or based on the violation of any such law, ordinance, regulation, order, or decree, whether by the Contractor or the Contractor's employees, subcontractors, or agents.

The Contractor, under [Title VI of the Civil Rights Act](#) and related statutes, agrees that in the hiring of employees for the performance of Work under this Contract or any subcontract hereunder, neither the Contractor, the subcontractor, nor any person acting on behalf of such Contractor or subcontractor shall, by reasons of race, religion, color, sex, national origin, disability or age, discriminate against any citizen of the United States in the employment of labor or workers, who is qualified and available to perform the Work to which the employment relates.

Neither the Contractor, the subcontractor, nor any person on their behalf shall, in any manner, discriminate against or intimidate any employee hired for the performance of Work under this Contract on account of race, religion, color, sex, national origin, disability or age.

Comply with [OAC-4123:1-3](#), entitled "Specific Safety Requirements of the Industrial Commission of Ohio Relating to Construction," as amended, and with the [Federal Occupational Safety and Health Act of 1970](#) and [Code of Federal Regulations, Title 29, Chapter XVII, Part 1926](#) and as amended.

107.02 Permits, Licenses, and Taxes. Procure all permits and licenses; pay all charges, fees, and taxes; and provide all notices necessary and incidental to the due and lawful prosecution of the Work.

107.03 Patented Devices, Materials, and Processes. Before employing any design, device, material, or process covered by letters of patent or copyright, provide for its use by suitable legal agreement with the patentee or owner. The Contractor and the Surety shall indemnify and save harmless the State, respective Local, any affected third party, or political subdivision from any and all claims for infringement of patented design, device, material, process, or any trademark or copyright, and shall indemnify the State for any costs, expenses, and damages that it may be obliged to pay by reason of any infringement, at any time during the prosecution or after the completion of the Work.

107.04 Restoration of Surfaces Opened by Permit.

~~LPA SHALL SPECIFY~~ [See contract documents](#)

107.05 Federal-Aid Provisions. When the United States Government pays for all or any portion of the Project's cost, the Work is subject to the inspection of the appropriate Federal agency.

Such inspections will not make the Federal Government a party to this Contract. The inspections will in no way interfere with the rights of either party to the Contract.

107.06 Sanitary Provisions. Provide and maintain sanitary accommodations in a neat condition for the use of employees and LPA representatives that comply with the requirements of the State and local Boards of Health, or of other authorities having jurisdiction over the Project.

107.07 Public Convenience and Safety. At all times, ensure that the Work interferes as little as possible with the traffic. Provide for the safety and convenience of the general public and the residents

along the highway and the protection of persons and property. Do not close any highways or streets unless specifically allowed by the Contract.

Any illegal drugs, drug paraphernalia, mobile drug labs or dumps, weapons or firearms found on the Project Right of Way shall be considered a potential crime scene and shall not be handled or moved. Immediately notify law enforcement and the Project Engineer.

107.08 Bridges Over Navigable Waters. Conduct all Work on navigable waters so that it does not interfere with free navigation of the waterways and that it does not alter the existing navigable depths, except as allowed by permit issued by the [U.S. Coast Guard](#). Work within the flood plain of a navigable stream may require a permit from the [U.S. Army Corps of Engineers](#). If an [U.S. Army Corps of Engineers](#) permit is required, provide all documentation submitted to obtain the permit(s) and a copy of the permit(s) to the LPA.

107.09 Use of Explosives. When the use of explosives is necessary for the prosecution of the Work, exercise the utmost care not to endanger life or property, including new Work. The Contractor is responsible for all damage resulting from the use of explosives.

Obtain written permission to perform in-stream blasting from the Chief of the Division of Wildlife, [Ohio DNR](#) according to [ORC 1533.58](#). Provide the Engineer with all documentation submitted to obtain this permit and with a copy of the permit.

The Contractor agrees, warrants, and certifies that it will observe State laws and local ordinances and regulations relative to the use and storing of explosives kept on the Project site.

Perform all blasting operations according to Item [208](#).

107.10 Protection and Restoration of Property. The Contractor is responsible for the preservation of all public and private property impacted by the Contractor's operations.

The Contractor is responsible for all damage or injury to property, during the prosecution of the Work, resulting from any act, omission, neglect, defective work or materials, or misconduct in the manner or method of executing the Work. The Contractor will remain responsible for all damage and injury to property until the Project is accepted under [109.12](#), except for portions of the Work accepted under [109.11](#).

If the Contractor causes any direct or indirect damage or injury to public or private property by any act, omission, neglect, or misconduct in the execution or the non-execution of the Work, then it must restore, at its own expense, the property to a condition similar or equal to that existing before the damage or injury.

If mail boxes, road, or street name signs and supports interfere with the Work, then remove and erect them in a temporary location during construction in a manner satisfactory to and as directed by the Engineer. After completion of the Work and before final acceptance of the Project, erect the mailboxes, road, or street name signs and supports in their permanent locations according to the plans unless otherwise directed by the Engineer. Consider the cost of this Work as incidental to the affected items.

Cooperate with the Engineer in protecting and preserving survey monuments that are affected by the Work. At the beginning of the Work, verify the position of all survey monuments in the area to be improved, according to [623](#). If survey monuments not shown in the Contract Documents are unexpectedly encountered, then protect, reference, and preserve them in the same manner as survey monuments that are shown in the Contract Documents.

Do not create staging areas, store materials and equipment, or borrow or waste materials in areas labeled as an environmental resources areas in the Contract Documents. All properties to be utilized

by the Contractor outside the project Work Limits must be cleared for all environmental resource impacts prior to the beginning of work. Environmental resources include but may not be limited to:

1. Cultural Resources
 - a. Buildings, structures, objects, and sites eligible for or listed on the [National Register of Historic Places](#)
 - b. Historic or prehistoric human remains, cemeteries, and/or burial sites (pursuant with [ORC 2909.05](#) and [2927.11](#))
2. Ecological Resources
 - a. Wetlands
 - b. Streams
 - c. Wooded areas with trees to be removed in excess of 8 inches diameter at breast height
3. Public Lands
 - a. Lands meeting the criteria of [49 U.S.C. 303](#), [23 CFR 771.135: 4\(f\)](#).
 - b. Lands meeting the criteria of [16 U.S.C. 4601-4](#), [36 CFR 59.1: 6\(f\)](#).
4. [FEMA Mapped 100 year Floodplains](#)
5. Hazardous Waste Areas

Except for locations utilized specifically for:

1. Parking of equipment between workdays for maintenance type projects:
2. Reuse of Clean Hard Fill as described in [CA-EW-20 \(ODOT Beneficial Reuse Form\)](#). Prior to transferring Clean Hard Fill from the project, fully execute form [CA-EW-20](#) and provide appropriate documentation to the Engineer as described for each reuse option.

All areas proposed to be utilized by the Contractor outside the project construction limits and not described above shall be reviewed by environmental Contractor(s) that are prequalified by the Department for each environmental resource. Exception (1.) noted above only applies to projects with “maintenance” in the project description. Have the consultant(s) certify that the proposed site to be utilized for the Contractor will not impact:

1. Cultural Resources
2. Ecological Resources
3. Public Lands
4. [FEMA Mapped 100 year Floodplains](#)
5. Hazardous Waste Areas

Provide all documentation and the consultant certification to the District [Office of Environmental Services](#) with a copy to the Engineer.

Should the areas proposed for use by the Contractor outside the project right of way limits contain environmental resources the Contractor is responsible to the LPA for all environmental clearances and permits prior to the beginning of work.

107.11 Contractor's Use of the Project Right-of-Way or Other LPA-Owned Property.

A. Disposal of Waste Material and Construction Debris and Excavation of Borrow on the Project Right-of-Way or on Other LPA-Owned Property. Dispose of waste material according to [105.16](#) and dispose of construction debris according to [105.17](#). In addition to the rights granted in [104.03](#), the Contractor's use of the Project Right-of-Way or other LPA-owned property for the disposal of waste material and construction debris and excavation of borrow material is restricted as follows:

1. If the Contract Documents identify locations for the disposal of waste material and construction debris or excavation of borrow material within the Project Right-of-Way or on other LPA-owned property, then only perform these operations in these designated locations.

2. If the Contract Documents do not identify locations for the disposal of waste material and construction debris or excavation of borrow material within the Project Right-of-Way or on other LPA-owned property, then do not Bid assuming that the LPA will make such locations available.

If the Contractor's request to use locations within the Project Right-of-Way or on other LPA-owned property is approved by the Engineer, then the LPA may allow the Contractor to dispose of waste material and construction debris or excavate borrow material for a fee of \$0.50 per cubic yard.

B. Contractor's Use of Portable Plants Within the Project Right-of-Way or on Other LPA-Owned Property. The Contractor's use of portable plants within the Project Right-of-Way or on other LPA-owned property is limited as follows:

1. If the Contract Documents identify locations within the Project Right-of-Way or on other LPA-owned property to place a portable plant, then only place a portable plant in these designated locations subject to the requirements of [107.11.C](#).

2. If the Contract Documents do not identify locations within the Project Right-of-Way or on other LPA-owned property to place a portable plant, then do not bid assuming that the LPA will make such locations available.

C. Placement of a Portable Plant within the Project Right-of-Way or on Other LPA-Owned Property. To place a portable plant within the Project Right-of-Way or on other LPA-owned property, comply with the following requirements:

1. Local noise ordinances.

2. Obtain any necessary [EPA](#) permits for the operation of the plant. Provide the LPA with a copy of the information submitted to obtain the permit and a copy of the permit.

3. Provide the Engineer written certification that the plant will supply material only for the Project for which it was approved. Do not use the plant to supply any other project or to sell materials commercially.

4. Submit a traffic control plan to the Engineer for approval that details the anticipated truck movements and provides acceptable protection, warning, and guidance to motorists, pedestrians, and the workers.

D. Equipment Storage and Staging. The Contractor may use, fee-free, any portion of the Project within the Project Right-of-Way for staging, equipment storage, or an office site with the approval of the Engineer, provided such usages do not interfere with the Work and are not prohibited by the Contract Documents. Do not bid in anticipation of using any properties within the Project Right-of-Way or LPA-owned property outside the Project Right-of-Way for equipment storage or staging.

E. Equipment Removal and Site Restoration. Remove all Contractor equipment and completely restore all utilized sites used as required by [104.04](#) before Final Acceptance as provided in [109.12](#).

107.12 Responsibility for Damage Claims and Liability Insurance. The Contractor shall indemnify and save harmless the State and all of its representatives, municipalities, counties, public utilities, any affected railroad or railway company, and any fee owner from whom a temporary Right-of-Way was acquired for the Project from all suits, actions, claims, damages, or costs of any character brought on account of any injuries or damages sustained by any person or property on account of any negligent act or omission by the Contractor or its subcontractors or agents in the prosecution or safeguarding of the Work.

The Contractor shall procure and maintain insurance for liability for damages imposed by law and assumed under this Contract, of the kinds and in the amounts hereinafter provided from insurance companies authorized to do business in the State by the [Ohio Department of Insurance](#). The cost of insurance is incidental to all contract items. Before the execution of the Contract by the PRC, furnish to the LPA a certificate or certificates of insurance in the form satisfactory to the LPA demonstrating compliance with this subsection. Provide an insurance certificate or certificates that show that the Contractor's liability and auto policies coverage are not reduced, restricted, or canceled until 30 days written notice has been given to the LPA by the insurer.

Mail all certificates and notices to: Administrator, [Office of Contracts](#), Ohio Department of Transportation, 1980 West Broad Street, Columbus, Ohio 43223.

Upon request, the Contractor shall furnish the LPA with a certified copy of each policy, including the provisions establishing premiums.

The types and minimum limits of insurance are as follows:

A. Workers' Compensation Insurance. Comply with all provisions of the laws and rules of the Ohio Bureau of Workers' Compensation covering all operations under Contract with the LPA whether performed by it or its subcontractors. In addition, if a portion of the Work is performed from a barge or ship or requires unloading material from a barge or ship on a navigable waterway of the United States, it is the responsibility of the Contractor to arrange coverage for that portion of the Work under the Longshore and Harborworkers' Compensation Act [[33 USC Section 901 et seq.](#)] and the [Jones Act](#) [[5 USC Section 751 et seq.](#)] and provide proof of coverage to the Department.

B. Commercial General Liability Insurance. The minimum limits for liability insurance are as follows:

General Aggregate Limit	\$2,000,000
Products - Completed Operations Aggregate Limit	\$2,000,000
Personal and Advertising Injury Limit	\$1,000,000
Each Occurrence Limit	\$1,000,000

Obtain the above minimum coverages through primary insurance or any combination of primary and umbrella insurance. In addition, the LPA will require the General Aggregate Limit on a per project basis.

Ensure that the Commercial General Liability Insurance policy names the State of Ohio, Local Public Agency, its officers, agents, and employees as additional insureds with all rights to due notices

in the manner set out above. Obtain Explosion, Collapse, and Underground (XCU) coverage at the same limits as the commercial general liability insurance policy. In addition, if blasting is to be performed, obtain XCU coverage providing a minimum Aggregate Limit of \$5,000,000 and Each Occurrence Limit of \$1,000,000. Submit proof of insurance, endorsements, and attachments to the Engineer prior to starting the Work.

C. Comprehensive Automobile Liability Insurance. The Comprehensive Automobile Liability policy shall cover owned, non-owned, and hired vehicles with minimum limits as follows:

Bodily Injury and Property Damage Liability Limit	
Each Occurrence	\$1,000,000

Insurance coverage in the minimum amounts set forth neither relieves the Contractor from liability in excess of such coverage, nor precludes the LPA from taking such other actions as are available to it under any other provisions of this Contract or otherwise in law.

Clearly set forth all exclusions and deductible clauses in all proof of insurance submitted to the LPA. The Contractor is responsible for the deductible limit of the policy and all exclusions consistent with the risks it assumes under this Contract and as imposed by law.

If the Contractor provides evidence of insurance in the form of certificates of insurance, valid for a period of time less than the period during which the Contractor is required by terms of this Contract, then the LPA will accept the certificates, but the Contractor is obligated to renew its insurance policies as necessary. Provide new certificates of insurance from time to time, so that the LPA is continuously in possession of evidence that the Contractor's insurance is according to the foregoing provisions.

If the Contractor fails or refuses to renew its insurance policies or the policies are canceled or terminated, or if aggregate limits have been impaired by claims so that the amount available is under the minimum aggregate required, or modified so that the insurance does not meet the requirements of [107.12.C](#), the LPA may refuse to make payment of any further monies due under this Contract or refuse to make payment of monies due or coming due under other contracts between the Contractor and the LPA. The LPA in its sole discretion may use monies retained pursuant to this subsection to renew or increase the Contractor's insurance as necessary for the periods and amounts referred to above. Alternatively, should the Contractor fail to comply with these requirements, the LPA may default the Contractor and call upon the Contractor's Surety to remedy any deficiencies. During any period when the required insurance is not in effect, the Engineer may suspend performance of the Contract. If the Contract is so suspended, the Contractor is not entitled to additional compensation or an extension of time on account thereof.

Nothing in the Contract Documents and insurance requirements is intended to create in the public or any member thereof a third party beneficiary hereunder, nor is any term and condition or other provision of the Contract intended to establish a standard of care owed to the public or any member thereof.

107.13 Reporting, Investigating, and Resolving Motorist Damage Claims.

~~LPA SHALL SPECIFY~~ [Contractor is responsible for reporting, investigating and resolving and damage claims. Contractor shall provide the LPA with documentation of resolution of each claim. Release of project retainage may be held until proper documentation of claim resolution has been received by the LPA.](#)

107.14 Opening Sections of Project to Traffic. The Engineer may order the Contractor to open a section of the Work to the safe use of traffic at any time. The LPA will make an adjustment according to [108.06](#) and [109.05](#) to compensate the Contractor for the added costs and delay, if any, resulting from such an opening.

107.15 Contractor's Responsibility for Work. Until the Final Inspector accepts the Work during the Final Inspection according to [109.12.A](#), the Contractor is responsible for the Project and will take every precaution against injury or damage to any part thereof by the action of the elements or from any other cause, whether arising from the execution or from the non-execution of the Work. Rebuild, repair, restore, and make good all injuries or damages to any portion of the Work occasioned by any of the above causes before final acceptance. Bear the expense of the repairs except when damage to the Work was due to unforeseeable causes beyond the control of and without the fault or negligence of the Contractor. Unforeseeable causes include but are not restricted to; (a) earthquake, floods, tornados, high winds, lightning or other catastrophes proclaimed a disaster or emergency, (b) slides, (c) civil disturbances, or (d) governmental acts.

In the event that the Engineer determines that damage to completed permanent items of Work results from traffic using a substantially completed section of Roadway, the LPA may compensate the Contractor for repair of the damage as authorized by Change Order. Additionally, if traffic permanently damages beyond use and of the following temporary maintenance of traffic items, the LPA may compensate the Contractor for replacement of the item as authorized by Change Order:

1. Arrow board.
 2. Work zone signal, pole, or controller.
 3. Lighting unit or pole.
 4. Changeable message sign.
 5. Work Zone Impact Attenuator
 6. Truck Mounted Impact Attenuator
 7. Digital Speed Limit Sign Assembly
- A.** Notify the Engineer of each occurrence of damage in writing within 10 Calendar Days.
- B.** Contact the local law enforcement agency to determine if the accident was investigated and a report filed. If an accident report was filed, obtain the report and notify the motorist, and copy their insurance company, via certified mail informing both that the motorist is responsible for the cost of damage repairs. If the motorist does not respond within 30 days, make a second attempt to contact the motorist and copy the insurance company via certified mail.
- C.** If no response is received from the motorist or insurance company within 30 days of the motorist receipt of the second notice, send a letter to the Engineer within eighteen months of the event and include documentation of good faith effort to seek recovery from responsible parties.
- D.** The LPA will make an adjustment according to [108.06](#) and [109.05](#) to compensate the Contractor for the added costs and delays, if any, resulting from the repair or replacement of damaged Work.

If there is no accident report on file and no means of identifying the responsible motorist, the Contractor may likewise be compensated to repair the damaged Work.

In case of suspension of Work by the Contractor or under the provisions of [105.01](#), the Contractor is responsible for the Project and shall take necessary precautions to prevent damage to the Project; provide for normal drainage; and erect any necessary temporary structures, signs, or other facilities at its expense. During such period of suspension of Work, properly and continuously maintain in an

acceptable growing condition all living material in newly established plantings, seedings, and soddings furnished under the Contract, and take adequate precautions to protect new tree growth and other important vegetative growth against injury.

The Engineer may direct the Contractor to remove graffiti any time during the Work. The LPA will make an adjustment according to [108.06](#) and [109.05](#) to compensate the Contractor for the added costs and delays, if any, resulting from all ordered graffiti removal.

107.16 Contractor's Responsibility for Utility Property and Services. At points where the Contractor's operations are adjacent to properties of railway, cable, telephone, and power companies, or are adjacent to other property, and any damage to their property may result in considerable expense, loss, or inconvenience, do not commence with the operation until all arrangements necessary for the protection of the property have been made.

Cooperate with the owners of any underground or overhead utility lines in their removal and rearrangement operations to ensure these operations progress in a reasonable manner, that duplication of rearrangement Work may be reduced to a minimum, and that services rendered by those parties will not be unnecessarily interrupted.

In the event interruption to underground or overhead utility services results from an accidental breakage or from being exposed or unsupported, immediately alert the occupants of nearby premises as to any emergency that the accidental breakage may create at or near such premises. Then notify the Engineer and the owner or operator of the utility facility of the disruption and cooperate with the said utility owner or operator in the restoration of service. If water service is interrupted, perform the repair work continuously until the service is restored unless the repair work is performed by the local governmental authority. Do not begin Work around fire hydrants until the local fire authority approves provisions for continued service.

107.17 Furnishing Right-of-Way. The LPA is responsible for securing all necessary Right-of-Way in advance of construction. The Bid Documents will indicate any exceptions. The LPA will notify all prospective Bidders in writing before the date scheduled for receipt of Bids regarding the specific dates certain parcels will be made available to the Contractor.

107.18 No Waiver of Legal Rights. The following LPA actions do not waive the LPA's rights or powers under the Contract, or any right to damages herein provided:

- A. Inspection by the Engineer or by any of Engineer's duly authorized representatives.
- B. Any order, measurements, or certificate by the PRC and/or CPE, or LPA representatives.
- C. Any order by the PRC and/or CPE or LPA representatives for the payments of money or the withholding of money.
- D. Acceptance of any Work.
- E. Any extension of time.
- F. Any possession taken by the LPA or its duly authorized representatives.

The LPA will not consider any waiver of a breach of this Contract to be a waiver of any other subsequent breach.

107.19 Environmental Protection. Comply with all Federal, State, and local laws and regulations controlling pollution of the environment. Avoid polluting streams, lakes, ponds, and reservoirs with fuels, oils, bitumens, chemicals, sediments, or other harmful materials, and avoid polluting the atmosphere with particulate and gaseous matter.

By execution of this contract, the Contractor, will be deemed to have stipulated as follows:

A. That any facility that is or will be utilized in the performance of this contract, unless such contract is exempt under the Clean Air Act, as amended ([42 U.S.C. 1857](#) et seq., as amended by Pub.L. 91-604), and under the Federal Water Pollution Control Act, as amended ([33 U.S.C. 1251](#) et seq., as amended by Pub.L. 92-500), [Executive Order 11738](#), and regulations in implementation thereof ([40 CFR 15](#)) is not listed, on the date of contract award, on the U.S. Environmental Protection Agency (EPA) List of Violating Facilities pursuant to [40 CFR 15.20](#).

B. That the firm agrees to comply and remain in compliance with all the requirements of [Section 114 of the Clean Air Act](#) and [Section 308 of the Federal Water Pollution Control Act](#) and all regulations and guidelines listed thereunder.

C. That the firm shall promptly notify the LPA of the receipt of any communication from the Director, [Office of Federal Activities, EPA](#), indicating that a facility that is or will be utilized for the contract is under consideration to be listed on the [EPA List of Violating Facilities](#).

D. That the firm agrees to include or cause to be included the requirements of paragraph 1 through 4 of this Section in every nonexempt subcontract, and further agrees to take such action as the government may direct as a means of enforcing such requirements.

Fording of streams is prohibited. Causeways for stream and river crossings or for Work below a bridge are permitted provided:

A. The causeway complies with the requirements of the [404 Permit](#) the LPA obtained for the Project.

B. The Contractor obtains a [404 Permit from the U.S. Army Corps of Engineers](#) if the LPA has not obtained such a permit. Obtain the [404 Permit](#) prior to beginning construction of the causeway. The LPA does not guarantee that the Contractor will be able to obtain a [404 Permit](#).

Comply with all current provisions of the Ohio Water Pollution Control Act ([OWPCA](#)), ([ORC Chapter 6111](#)). The LPA will obtain a storm water permit under the [OWPCA](#) provisions when the plan work acreage requires a permit. Apply for a permit to cover operations outside the Project limits shown on the plans as required by the [OWPCA](#) provisions. When the LPA has not applied for a permit on the Project and a permit is required under the provisions of the [OWPCA](#) because of the total area of the Contractor's work, apply for, obtain, and comply with the required permit for both the Work within Project limits and the Contractor's work.

The LPA has obtained the required permits from the [U.S. Army Corps of Engineers](#) and [Ohio EPA](#) for Work in the "Waters of the United States" and isolated wetlands under [ORC Chapter 6111](#). Comply with the requirements of these permits.

When equipment is working next to a stream, lake, pond, or reservoir, appropriate spill response equipment is required. Do not stockpile fine material next to a stream, lake, pond, or reservoir.

Take precautions to avoid demolition debris and discharges associated with the excavation and hauling of material from entering the stream. Remove any material that does fall into the stream as soon as possible.

When excavating in or adjacent to streams, separate such areas from the main stream by a dike or barrier to keep sediment from entering the stream. Take care during the construction and removal of such barriers to minimize sediment entering the stream.

Contain, collect, characterize and legally dispose of all liquid waste and sludge generated during the work. Do not mix wastes with storm water. Do not discharge any liquid waste without the appropriate regulatory permits. Manage liquid waste and sludge in accordance with [ORC Chapter 6111](#) and all other laws, regulations, permits and local ordinances relating to this waste. Liquid waste management is incidental to the Work unless otherwise specified in the contract.

Control the fugitive dust generated by the Work according to [OAC-3745-17-07\(B\)](#), [OAC-3745-17-08](#), [OAC-3745-15-07](#), and [OAC-3745-17-03](#) and local ordinances and regulations. Prior to the initiation of abrasive coating removal, pavement cutting or any other construction operation that generates dust, demonstrate to the Engineer that construction related dust will be controlled with appropriate Reasonable Available Control Measures (RACM) as described in [OEPA Engineering Guide #57](#).

In addition, use dust control measures when fugitive dust creates unsafe conditions as determined by the Engineer. Perform this work without additional compensation except for Item [616](#).

Perform open burning according to [105.16](#).

107.20 Civil Rights. Comply with Federal, State, and local laws, rules, and regulations that prohibit unlawful employment practices including that of discrimination because of race, religion, color, sex, national origin, disability or age and that define actions required for Affirmative Action and Disadvantaged Business Enterprise (DBE) programs.

107.21 Prompt Payment. In accordance with [ORC 4113.61](#), make payment to each subcontractor and supplier within 10 Calendar Days after receipt of payment from either the Department or LPA for Work performed or materials delivered or incorporated into the Project, provided that the pay estimate prepared by the Engineer includes Work performed or materials delivered or incorporated into the public improvement by the subcontractor or supplier. Contractors are prohibited from holding retainage from subcontractors that can provide a bond. For unbonded subcontractors and suppliers, promptly release any retainage held, as set forth in any subcontractor or supplier agreement, 30 days after the work is satisfactory completed. For the purposes of this section, satisfactory completed will be interpreted as when the subcontractor has completed all physical work and submitted any necessary documentation required by the specifications and the LPA. No subcontract provision shall permit the Contractor to delay subcontractor's retainage payments until the Project's final payment.

Also require that this contractual obligation be placed in all subcontractor and supplier contracts that it enters into and further require that all subcontractor and suppliers place the same payment obligation in each of their lower tier contracts. If the Contractor, subcontractors, or supplier subject to this provision fail to comply with the 10 Calendar Day requirement, the offending party shall pay, in addition to the payment due, interest in the amount of 18 percent per annum of the payment due, beginning on the eleventh Calendar Day following the receipt of payment from either the Department or LPA and ending on the date of full payment of the payment due plus interest.

Repeated failures to pay subcontractors and suppliers timely pursuant to this subsection will result in a finding by the LPA that the Contractor is in breach of Contract and subject to all legal consequences that such a finding entails. Further, repeated failures to pay timely pursuant to this subsection will result in a lower evaluation score for the Contractor and those subcontractors who are subject to evaluation by the Department.

107.22 Unmanned Aircraft Systems. If the project requires or anticipates the use of Unmanned Aircraft Systems within LPA Right of Way, the Contractor will follow proper risk assessment and federal regulations in accordance with [Supplement 1132](#).

108 PROSECUTION AND PROGRESS

108.01 Subletting of the Contract. Perform Work amounting to not less than 30 percent of the Contract Price with its own organization. The phrase “its own organization” includes only workers employed and paid directly, inclusive of employees who are employed by a lease agreement acceptable to the LPA, and equipment owned or rented with or without operators by the Contractor. The phrase does not include employees or equipment of a subcontractor, assignee, or agent of the Contractor. Provide ODOT Division of Opportunity, Diversity, and Inclusion with a copy of all Disadvantaged Business Enterprise subcontracts.

The Contractor’s percentage of the total Contract Price includes the cost of materials and manufactured products purchased by the Contractor, but not the cost of materials and manufactured products purchased by subcontractors.

The PRC or CPE will calculate the Contractor’s percentage based on the quantities shown in the Proposal and the unit prices of the contract items to be performed by the Contractor’s organization. If the Contractor performs only a portion of a contract item, then the PRC or CPE will determine the proportional value administratively on the same basis. The PRC or CPE will follow this procedure even when the part not subcontracted consists only of the procurement of materials. However, if a firm both sells the materials to the Contractor and performs the Work of incorporating the materials into the Project, then the PRC or CPE will consider these two phases in combination and as a single subcontract. If an affiliate of the firm either sells the materials or performs the Work, the LPA may refuse approval. An affiliate is one who has some common ownership or other close relation to said firm.

Use actual subcontract prices for calculating compliance with any Disadvantaged Business Enterprise (DBE) percentage subcontracting obligations. If only a part of a contract item is sublet, then determine its proportional value administratively on the same basis. The PRC and/or CPE will follow this procedure even when the part not sublet consists only of procuring materials. However, if a firm both sells the materials to the Contractor and performs the work of incorporating the materials into the Project, then the LPA will consider these two phases in combination and as a single subcontract. If an affiliate of the firm either sells the materials or performs the Work, the LPA may refuse approval.

108.02 Partnering. It is the intent of the LPA to partner every project. The purpose of Partnering is to develop a proactive effort and spirit of trust, respect, and cooperation among all stakeholders in a project. Partnering does not affect the terms and conditions of the Contract. The Partnering process in this section is Self-facilitated Partnering performed by the Project personnel. Costs associated with the Self-facilitated Partnering process are incidental to the Contract.

A. Preconstruction Meeting. Meet with the Engineer for a Preconstruction Meeting before beginning the Work. At or before the meeting, submit the initial progress schedule to the PRC. Prepare the schedule according to [108.03](#).

Furnish a list of proposed subcontractors and material suppliers at or before the Preconstruction Meeting. If the Contractor fails to provide the required submissions at or before the Preconstruction Meeting, the Engineer may order the meeting suspended until they are furnished. Do not begin the Work until the meeting is reconvened and concluded or the Engineer gives specific written permission to proceed.

B. Initial Partnering Session. In conjunction with the PRC and/or CPE, determine whether the Initial Partnering Session will be conducted as part of the Preconstruction Meeting or as a separate meeting. Partnering shall have its own agenda with specific time set aside to develop the necessary partnering protocols. Develop the Partnering agenda with the PRC and/or CPE.

Identify and invite all stakeholders necessary to make the Project successful including utility companies, other transportation entities (i.e., railroads), community leaders, all Project participants including subcontractors.

During the Initial Partnering Session, consider developing Partnering teams consisting of LPA and Contractor senior personnel and Project personnel. Consider the following items for discussion:

1. Identifying and developing a consensus on project goals consistent with the contractual obligations, including specific goals concerning safety, quality, schedule, and budget.
2. Deciding how the teams will measure progress on Project goals.
3. Identifying any potential risks to the Project's success, mitigation strategies and an implementation plan for the appropriate strategies.
4. Defining key issues, project concerns, joint expectations, roles of key partnership leaders, lines of decision making authority, and share relevant information to help determine the scope of the Partnering efforts.
5. Identifying any opportunities for project enhancement, enhancement strategies and a specific action plan for implementing strategies.
6. Developing a communication protocol to enhance communication on the Project
7. Developing an issue identification and resolution process that identifies and attempts to resolve issues at the level closest to the work. The issue identification and resolution process will develop all the necessary steps for issue elevation including Notice and Mitigation defined in [108.02.F](#) and the Dispute Resolution and Administrative Claims Process defined in [108.02.G](#).

C. Progress Meetings. Hold monthly Progress Meetings unless the frequency is otherwise determined at the Preconstruction Meeting. Coordinate with the Engineer to determine agenda topics prior to each meeting. The purpose of Progress Meetings is to keep open communication between the Contractor and the Engineer. The senior personnel team is encouraged to participate in all Progress Meetings. Include Partnering as an agenda item at the Progress Meetings.

D. Post-milestone Meeting. In conjunction with the PRC and/or CPE, determine whether the Post-milestone Meeting will be conducted as part of the Progress Meeting or as a separate meeting for multi-year, multi-phase, or projects with critical items of work or milestone dates. Consider discussing and updating items from the Initial Partnering Session in addition to items specific to the Project. All stakeholders should be invited to attend.

E. Partnering Monitoring.

~~LPA SHALL SPECIFY IF DESIRED~~ [Omitted](#)

F. Mitigation and Notice. Mitigation of any issue, whether caused by the LPA, Contractor, third-party or an intervening event, is a shared contract and legal requirement. Mitigation efforts include, but are not limited to, re-sequencing work activities, acceleration, and substitution of materials. The Contractor and Engineer must explore and discuss potential mitigation efforts in a timely manner.

1. Contractor Initial Oral Notification. Provide immediate oral notification to the PRC and/or CPE upon discovering a circumstance that may require a revision to the Contract Documents or may result in a dispute. Upon notification, the Engineer will attempt to resolve the identified issue as quickly as possible.

2. Contractor Written Early Notice. If the PRC and/or CPE has not resolved the identified issue within two (2) working days after receipt of oral notification, provide written notice to the PRC and/or CPE of any circumstance that may require a revision to the Contract Documents or may result in a dispute. This early notice must be given by the end of the second working day following the occurrence of the circumstance.

The PRC and/or CPE and Contractor shall maintain records of labor, equipment, and materials used on the disputed work or made necessary by the circumstance. Such records will begin when early notice is received by the PRC and/or CPE. Tracking such information is not an acknowledgement that the LPA accepts responsibility for payment for this disputed work.

If an issue is not resolved through the initial mitigation efforts, either abandon or escalate to the Dispute and Administrative Claims Process defined in [108.02.G](#).

G. Dispute Resolution and Administrative Claims Process. Whenever an issue is elevated to a dispute, the parties shall exhaust the LPA's Dispute Resolution and Administrative Claim process set forth below as a condition precedent to filing an action in the Ohio Court of Claims. The following procedures do not otherwise compromise the Contractor's right to seek relief in any Ohio Court with legal jurisdiction.

All parties to the dispute must adhere to the Dispute Resolution and Administrative Claim process. Do not contact LPA personnel who are to be involved in higher tiers until a decision has been issued by the previous tier. LPA personnel involved in higher steps reviews will not consider a dispute until the previous tier has properly reviewed the dispute and issued a decision.

Failure to meet any of the timeframes outlined below or to request an extension will terminate further review of the dispute and serve as a waiver of the Contractor's right to file a claim.

Disputes and claims by subcontractors and suppliers may be pursued by the Contractor on behalf of subcontractors or suppliers. Disputes and claims by subcontractors and suppliers against the LPA but not supported by the Contractor will not be reviewed by the LPA. Disputes and claims of subcontractors and suppliers against the Contractor will not be reviewed by the LPA.

Continue with all Work during the Dispute Resolution and Administrative Claims process, including that which is in dispute. The LPA will continue to pay for Work.

The LPA will not make the adjustments allowed by [104.02.B](#), [104.02.C](#), and [104.02.D](#) if the Contractor did not give notice as specified in [108.02.F.1](#) and [108.02.F.2](#). This provision does not apply to adjustments provided in Table [104.02-2](#).

LPA SHALL SPECIFY

~~Dispute Resolution Templates can be found on the following ODOT Office of Local Programs Website:~~

~~<http://www.dot.state.oh.us/Divisions/Planning/LocalPrograms/Pages/LocalLetProcesses.aspx>The City of Mentor Dispute Resolution Process is described in the Supplementary Consitions section of the specifications.~~

H. Post Construction Meeting. The LPA will conduct a Post Construction Meeting with the Contractor prior to the project finalization. The PRC and/or CPE will invite the design agency and any other stakeholders deem necessary including utility companies, other transportation entities (i.e.

railroads), community leaders, all Project participants including subcontractors performing critical work to attend this meeting.

Consider the following items for discussion:

1. Project Safety.
2. How were the goals evaluated or measured?
3. How were foremen/ workers involved in the Partnering process?
4. How were the subcontractors involved in the Partnering process?
5. How were relationships with key stakeholders managed?
6. Teambuilding activities or unique motivational activities.

I. Partnering Close-Out Survey.

SPECIFICATION IS NOT INCLUDED IN THIS CONTRACT

108.03 Prosecution and Progress. Start the Work according to [108.02](#). Notify the Engineer at least 24 hours before starting the Work. If the prosecution of the Work is suspended, notify the Engineer a minimum of 24 hours in advance of resuming operations.

Pursue the Work diligently and continuously as to complete the Project by the Completion Date.

A. Progress Schedule.

1. General. Furnish a bar chart progress schedule to the PRC and/or CPE for review at or before the Preconstruction Meeting. The Engineer will review the schedule and within 14 calendar days of receipt, will either accept the schedule or provide the Contractor with comments. Acceptance of the schedule does not revise the Contract Documents. Provide clarification or any needed additional information within 10 days of a written request by the Engineer. The LPA will withhold Estimates until the Engineer accepts the schedule. The Engineer will not measure or pay for the preparation of the schedule and schedule updates directly, but the cost of preparing and updating the schedule is incidental to all Contract Items.

a. Include the following Administrative Identifier Information:

- (1) Project Number
- (2) County
- (3) Route Number
- (5) PID Number
- (8) Completion Date
- (9) Contractor's Name
- (10) Contractor's Dated Signature
- (11) LPA's Dated Acceptance Signature

Provide a working day schedule that shows the various activities of Work in sufficient detail to demonstrate a reasonable and workable plan to complete the Project by the Completion Date. Show the order and the sequence for accomplishing the Work. Describe all activities in sufficient detail so that the Engineer can readily identify the Work and measure the progress of each activity. The bar chart schedule must reflect the scope of work, required phasing, maintenance of traffic requirements, interim completion dates, the Completion Date, and other project milestones established in the Contract

Documents. Include activities for submittals, working and shop drawing preparation, submittal review time for the LPA, material procurement and fabrication, and the delivery of materials, plant, and equipment, and other similar activities. The schedule must be detailed on letter or legal sized paper.

b. Activity requirements are discussed in further detail as follows:

(1) Activity Description. Assign each activity an unambiguous descriptive word or phrase. For example, use "Excavate Area A," not "Start Excavation."

(2) Activity Original Duration. Indicate a planned duration in calendar days for each activity. Do not exceed a duration of 20 working days for any activity unless approved by the Engineer. Do not represent the maintenance of traffic, erosion control, and other similar items as single activities extending to the Completion Date. Break these Contract Items into component activities in order to meet the duration requirements of this paragraph.

2. Early Completion Schedule. An Early Completion Schedule is defined as a baseline schedule or update schedule which anticipates completion of all work prior to the Completion Date established by the contract documents and the Contractor submits as an Early Completion Schedule. In the event that an Early Completion Schedule is accepted, the Engineer will initiate a change order amending the Completion Date to the finish date shown on the accepted Early Completion Schedule. The amended Completion Date will be effective upon execution of that change order and all contract provisions concerning the Completion Date such as incentives, disincentives, excusable delays, compensable delays, and liquidated damages will be measured against the amended Completion Date. The Contractor may elect not to execute the change order amending the Completion Date; however, in so doing, the Contractor waives its rights to delay damages in meeting the projected early Completion Date.

3. Updated Progress Schedule. Submit an updated progress schedule when ordered by the Engineer. The Engineer may request an updated progress schedule when progress on the work has fallen more than 14 calendar days behind the latest accepted progress schedule. Information in the updated schedule must include a "% work completed" value for each activity.

4. Recovery Schedule. If the progress schedule projects a finish date for the Project more than 14 calendar days later than the Completion Date, submit a revised schedule showing a plan to finish by the Completion Date. The LPA will withhold Estimates until the Engineer accepts the revised schedule. The Engineer will use the schedule to evaluate time extensions and associated costs requested by the Contractor.

108.04 Limitation of Operations. Limit operations to prevent unnecessary inconvenience to the traveling public. If the Engineer concludes that the extent of the Contractor's Work unnecessarily inconveniences the public or concludes limiting operations are necessary to protect the existing or new construction from damage, the Engineer will require the Contractor to finish portions of Work in progress before starting new Work.

108.05 Character of Workers Methods and Equipment. Provide personnel with sufficient skills and experience to perform assigned tasks.

Ensure that no debarred individuals listed on the Federal website:

<https://www.sam.gov/SAM/pages/public/samStatusTracker.jsf>

or State debarment list at the website:

<http://www.dot.state.oh.us/divisions/contractadmin/Pages/default.aspx>

act in any ownership, leadership, managerial, or other similar position that could influence the operations of an entity doing business with the LPA.

If the Engineer gives written notification that specific Contractor or subcontractor personnel are improperly performing the Work, intemperate, disorderly, or creating a hostile work environment, remove the identified personnel from the Project. Do not allow removed personnel to return to the Project without the Engineer's approval.

The Engineer may suspend the Work by written notice under this subsection for the following reasons:

A. The Contractor does not furnish sufficient skilled and experienced personnel to complete the Project by the Completion Date.

B. The Contractor does not remove personnel from the Project as directed in writing by the Engineer.

Use equipment of sufficient size and mechanical condition to complete the Project by the Completion Date. Ensure that the equipment does not harm the roadway, adjacent property, other highways, workers, or the public.

If the Contract Documents do not prescribe the methods and equipment required to accomplish the Work, determine the methods or equipment necessary to complete the Work according to the Contract.

If the Contract Documents specify methods and equipment to perform the Work, use such methods and equipment, unless others are authorized by the Engineer. Obtain the Engineer's written approval before substituting alternate methods or equipment. To obtain the Engineer's approval, submit a written description of the alternate methods and equipment proposed and an explanation of the reasons for making the change. The Engineer's approval of the substitute methods and equipment does not relieve the Contractor of the obligation to produce Work according to [105.03](#). If after trial use of the substituted methods or equipment, the Engineer determines that the Work does not conform to the Contract Documents, then complete the remaining Work using the specified methods and equipment. Remove all deficient Work and replace it according to the Contract Documents, or take such other corrective action as directed by the Engineer. The Engineer's authorization to substitute alternate methods and equipment will not change the basis of payment for the construction items involved or the Contract Time.

108.06 Determining a Time Extension to the Completion Date and Payment for Excusable Delays.

A. General. The LPA will only extend the Completion Date if an excusable delay, as specified in [108.06.B](#) or [108.06.D](#), delays Work on the critical path shown on the accepted progress schedule and impacts the Completion Date. The critical path is defined as; the longest path of activities in the project that determines the project schedule completion date. The activities that make-up the critical path of activities are the "Critical Activities." Any extension of the Completion Date will be executed by a change order.

Mitigation of any delay, whether caused by the LPA, Contractor, third-party or an intervening event, is a shared contract and legal requirement. Mitigation efforts include, but are not limited to, re-sequencing work activities, acceleration, and continuation of work through an otherwise planned shutdown period. The Contractor and Engineer must explore and discuss potential mitigation efforts in a timely manner.

The LPA will not evaluate a request for extension of the Completion Date unless the Contractor notifies the Engineer as specified in [108.02.F](#). Notification shall be in writing to the Engineer within

30 days following the termination of the event giving rise to the request and shall be accompanied by supporting analysis and documentation.

The Engineer will evaluate the Contractor's analysis and determine the time extension due, if any. The Engineer will measure all time extensions in Calendar Days. For delays measured in Workdays, the Engineer will convert Workdays to Calendar Days by multiplying by 1.4 for a 5-day work week or less; 1.2 for a 6-day work week; and 1 for a 7-day work week; and extend the Completion Date by the resulting number of Calendar Days plus any holidays the Contractor does not normally work that occur in the extension period. When the conversion of Workdays to Calendar Days results in a decimal of 0.5 or greater, the Engineer will round the number of Calendar Days to the next highest whole number. When the conversion results in a decimal less than 0.5, the Engineer will delete the decimal portion of the Calendar Days.

The Engineer will not grant an extension of time for delays incurred from December 1 to April 30 unless the Contractor's accepted progress schedule depicts work on the critical path occurring during this period.

The Engineer may order the Contractor to continue Work after November 30 and compensate the Contractor for costs incurred due to cold weather Work.

The Contractor's plea that insufficient time was specified is not a valid reason for an extension of time.

The LPA will relieve the Contractor from associated liquidated damages, as specified in [108.07](#), if the Engineer extends the Completion Date under [108.06.A](#).

The extended Completion Date shall then have the same standing and effect as though it was the original Completion Date.

If the Contractor contends that an excusable delay is also compensable, as specified in [108.06.D](#), submit a detailed cost analysis of the requested additional compensation along with the request for extension of Completion Date.

B. Excusable, Non-Compensable Delays. Excusable, non-compensable delays are delays that are not the Contractor's or the LPA's fault or responsibility. The Engineer will not grant additional payment for excusable, non-compensable delays.

The following are excusable, non-compensable delays:

1. Delays due to floods, tornadoes, lightning strikes, earthquakes, or other cataclysmic phenomena of nature.
2. Delays due to weather as specified in [108.06.C](#).
3. Extraordinary delays in material deliveries the Contractor or its suppliers cannot foresee or avoid resulting from freight embargoes, government acts, or area-wide material shortages. Delays due to the Contractor's, subcontractor's, or supplier's insolvency or mismanagement are not excusable.
4. Delays due to civil disturbances.
5. Delays from fires or epidemics.
6. Delays from labor strikes that are beyond the Contractor's, subcontractor's, or supplier's power to settle and are not caused by improper acts or omissions of the Contractor, subcontractor, or supplier.
7. Added quantities that delay an activity on the critical path.
8. All other delays not the Contractor's and Department's fault or responsibility.

C. Extension to the Completion Date for Weather or Seasonal Conditions. A weather day is defined as a workday that weather or seasonal conditions reduced production by more than 50 percent on items of work on the critical path. Submit the dates and number of weather days in writing to the Engineer at the end of each month. In the event the Contractor fails to submit weather days at the end of each month the Engineer will determine the dates and number of weather days from project records.

Delays caused by weather and seasonal conditions should be anticipated and will be considered as the basis for an extension of time when the Contractor’s accepted progress schedule depicts Work on the critical path and the actual workdays lost exceeds the number of work days lost each month as determined by Table [108.06-1](#).

TABLE 108.06-1

Month	Number of Workdays Lost Due to Weather
January	8
February	8
March	7
April	6
May	5
June	5
July	4
August	4
September	5
October	6
November	6
December	6

This table applies to the duration between contract execution and original completion date. Extensions for weather days beyond the original completion date will be for the actual workdays lost each month.

Lane closures within the project, 60 days or less as indicated in the contract documents, which are impacted by weather will be extended for the actual work days lost each month. Lane closures within the project, 61 days or longer as indicated in the contract documents, which are impacted by weather will be extended when the actual work days lost exceeds the number of anticipated work days lost each month as determined by Table 108.06-1.

The Engineer will not consider weekends and holidays as lost workdays unless the Contractor normally works those days or unless the Engineer directs the Contractor to work those days.

D. Excusable, Compensable Delays. Excusable, compensable delays are delays that are not the Contractor’s fault or responsibility, and are the LPA’s fault or responsibility or are determined by judicial proceeding to be the LPA’s sole responsibility or are the fault and responsibility of another local government. For the following excusable, compensable delays, the Engineer will extend the Completion Date if the conditions specified in [108.06.A](#) are met:

1. Delays due to revised Work as specified in [104.02.B](#), [104.02.D](#), or [104.02.F](#).
2. Delays due to utility or railroad interference within the Project limits.
3. Delays due to an Engineer-ordered suspension as specified in [104.02.C](#).
4. Delays due to acts of the government or a political subdivision other than the LPA.

5. Delays due to the neglect of the LPA or its failure to act in a timely manner.

Compensation for excusable, compensable delays will be determined by the Engineer according to [109.05.D](#).

E. Non-Excusable Delays. Non-excusable delays are delays that are the Contractor's fault or responsibility. All non-excusable delays are non-compensable.

F. Concurrent Delays. Concurrent delays are separate critical delays that occur at the same time. When a non-compensable delay is concurrent with a compensable delay, the Contractor is entitled to additional time but not entitled to additional compensation.

108.07 Failure to Complete on Time. If the Contractor fails to complete the Work by the Completion Date, then the PRC and/or CPE, if satisfied that the Contractor is making reasonable progress, and deems it in the best interest of the public, may allow the Contractor to continue in control of the Work. The LPA will pay the Contractor for Work performed on the Project less any liquidated damages incurred.

If the Work is not completed by the Completion Date and the PRC and/or CPE permits the Contractor to remain in control, prosecute the Work at as many different places, at such times, and with such forces as the PRC requests. Provide a written plan for the completion of the Work.

For each calendar day that Work remains uncompleted after the Completion Date, the LPA will deduct the sum specified herein from any money due the Contractor, not as a penalty, but as liquidated damages. The Director will adjust the Completion Date or other contractually mandated dates for delays specified in [108.06.B.7](#) and [108.06.D](#).

Permitting the Contractor to continue and complete the Work or any part of the Work after the Completion Date, or after extensions to the Completion Date, will in no way operate as a waiver on the part of the LPA of any of its rights under the Contract.

The PRC may stop deducting liquidated damages when:

- A. The Work is substantially complete and the project is available for use as intended by the contract.
- B. The Contractor is diligently pursuing the remaining Work.
- C. The Work remaining will not interfere with the intended use of the project and will not impact traffic. For the limited purposes of assessing liquidate damages, the closing of a shoulder is not considered an impact upon traffic.
- D. All contract safety items are complete and operational. These safety items include but are not limited to signs, pavement markings, guardrail, attenuators, and signals. Raised pavement markers (RPM) are required safety items if the roadway section involved had RPMs before the project started.
- E. Deemed reasonable and appropriate by the PRC and/or CPE.

The Contractor may submit a request for waiver of liquidated damages to the LPA within 30 days of the assessment of liquidated damages.

TABLE 108.07-1 SCHEDULE OF LIQUIDATED DAMAGES

Original Contract Amount (Total Amount of the Bid)		Amount of Liquidated Damages to be Deducted for each Calendar Day of Overrun in Time
From More Than	To and Including	
\$0.00	\$500,000	\$450
\$500,000	\$2,000,000	\$650
\$2,000,000	\$10,000,000	\$1,000
\$10,000,000	\$50,000,000	\$1,700
Over \$50,000,000		\$3,100

108.08 Unsatisfactory Progress and Default of Contractor. The PRC and/or CPE will notify the Contractor in writing of unsatisfactory progress for any of the following reasons:

- A. The Contractor has not commenced the Work by the dates established in the schedule.
- B. The Contractor does not proceed with the Work in a manner necessary for completion of the Project by the Completion Date.
- C. The Contractor is performing the Work improperly.
- D. The Contractor abandons, fails, or refuses to complete the Work.
- E. Any other reason the PRC and/or CPE believes jeopardizes completion of the Work by the Completion Date.

If the Contractor does not respond to the satisfaction of the PRC and/or CPE, the PRC and/or CPE may declare the Contractor in default and may notify the Contractor and Surety that the responsibility to complete the Work is transferred to the Surety. Upon receipt of this notification, the Contractor's right to control and supervise the Work will immediately cease. The defaulted Contractor will not be compensated for costs resulting from the default and is not eligible to be retained by the Surety to complete the Work. If it is determined that the LPA's default of the Contractor according to [108.08](#) is wrongful, then the default will revert to a termination of the Contract according to [108.09](#).

108.09 Termination of the Contract for Convenience of the LPA. The PRC and/or CPE may terminate the Contract at any time for the convenience of the LPA. The LPA will compensate the Contractor according to [109.04](#) and [109.05](#) for termination of the Contract for the convenience of the LPA.

108.10 Payroll Records. Keep payroll records as specified in [ORC 4115.07](#) or as required by Federal law.

Authorized representatives of the PRC and/or CPE may inspect the certified payroll and other payroll records. Upon completion of the Work and before receiving the final estimate and when required by [ORC 4115.07](#), submit an affidavit stating that wages have been paid according to the minimum rates specified in the Contract Documents.

109 ACCEPTANCE, MEASUREMENT, AND PAYMENT

109.01 Measurement of Quantities. The LPA will measure the quantities of Work and calculate payments based on the method of measurement and basis of payment provisions provided in these Specifications. When the following units of measure are specified, the LPA will measure quantities as described below unless otherwise specified in the Contract Documents. The accuracy of individual pay item estimate payments will be one decimal more accurate than the unit of measure denoted for the pay item.

Lump Sum. Not measured. Describes payment as reimbursement for all resources necessary to complete the Work. When a complete structure or structural unit is specified as the unit of measurement, the unit will include all necessary fittings and accessories.

Each. Measured by the number of individual items of Work completed.

Foot (Meter). Measured parallel to the longitudinal base or foundation upon which items are placed, or along the longitudinal surface of the item. Measured vertically to the nearest 0.1 foot (0.01 m), with a minimum vertical measurement of 1 foot (0.10 m), at each unit.

Square Yard or Square Foot (Square Meter). Measured by a two-dimensional area method on the surface of the item.

M Square Feet. One thousand square feet.

Cubic Yard (Cubic Meter). Measured by a three-dimensional volume method. Measure all “loose material” or material “measured in the vehicle” by the cubic yard (cubic meter). Haul material “measured in the vehicle” in approved vehicles and measure in the vehicle at the point of delivery. For this purpose, use approved vehicles of any type or size satisfactory to the Engineer, provided the vehicle’s bed is of such type that the actual contents are readily and accurately determined. Unless all approved vehicles on a job are of uniform capacity, each approved vehicle must bear a legible identification mark indicating the specific approved capacity. The Inspector may reject all loads not hauled in such approved vehicles.

Cubic Yard (Cubic Meter) for Asphalt Concrete. Measure as specified in [401.21](#).

Acre (Hectare). Measured by a two-dimensional area method on the surface to the nearest 0.1 acre (0.05 ha).

Pound (Kilogram). Measured by actual item net weight avoirdupois (mass).

Ton (Metric Ton). The term “ton” means the short ton consisting of 2000 pounds avoirdupois. The term “metric ton” means 1000 kilograms. Weigh all materials that are proportioned by weight on accurate and approved scales that are operated by competent, qualified personnel at locations approved by the Engineer. However, car weights will not be acceptable for materials to be passed through mixing plants. If trucks are used to haul material being paid for by weight, weigh the empty truck at least once daily and as the Engineer directs and only if the weight of the truck is used in determining the ticket weight. Place a plainly legible identification mark on each truck bearing the weight of the truck.

For Work on a tonnage basis, file with the Engineer receipted freight bills for railroad shipments and certified weight-bills when materials are received by any other method, showing the actual tonnage used. For Work on a volume basis, itemize evidence of the volume used.

Gallon (Liter). Measured by actual item liquid volume. The Department will measure the following materials by the gallon (liter) at the following temperatures:

Temperatures	Items
60 °F (16 °C)	Creosote for Priming Coat, Creosote Oil, Creosote Solutions for Timber Preservatives, Asphalt Primer for Water-proofing, and Liquefier
100 °F (38 °C)	RC, MC Asphalt Emulsions, CBAE, Primer 20, and Primer 100
300 °F (149 °C)	Asphalt Binder

Measure tank car outage of asphalt material at its destination before any material has been removed from the tank car according to [Supplement 1060](#).

Convert the net weight of asphalt material shipments to gallons (liters) at the specified pay temperature according to [Supplement 1060](#).

Convert the gallons (liters) at the measured temperature to gallons (liters) of asphalt material at the specified pay temperature according to [Supplement 1060](#).

M Gallon. One thousand gallons.

Thousand Board Feet, MBF (Cubic Meter). Measure timber by MBF (cubic meter) actually incorporated in the structure. Base the measurement on nominal widths, thicknesses, and the extreme length of each piece.

Standard Manufactured Items. When standard manufactured items are specified such as fence, wire, plates, rolled shapes, pipe conduit, etc., and these items are identified by size, unit weight, section dimensions, etc., such identification will be to nominal weights or dimensions set by the industry.

109.02 Measurement Units. The Department will measure using either English or metric units as indicated in the Contract Documents. Use the Tables [109.02-1](#) and [109.02-2](#) to convert units when required. If Tables [109.02-1](#) and [109.02-2](#) do not provide a required factor, then use the appropriate factor provided in the [IEEE/ASTM SI 10](#).

TABLE 109.02-1 ENGLISH TO SI (METRIC) CONVERSION FACTORS

Symbol	When You Know	Multiply By	To Find	Symbol
Length				
mil	mils	25.4	micrometers	μm
in	inches	25.4	millimeters	mm
ft	feet	0.3048	meters	m
yd	yards	0.9144	meters	m
mi	miles	1.609347	kilometers	km
Area				
in ²	square inches	645.16	square millimeters	mm ²
ft ²	square feet	0.09290304	square meters	m ²
yd ²	square yards	0.8361274	square meters	m ²
ac	acres	0.4046873	hectares	ha
ac	acres	4046.873	square meters	m ²
mi ²	square miles	2.589998	square kilometers	km ²
Volume				
fl oz	fluid ounces	29.57353	milliliters	mL
gal	gallons	3.785412	liters	L
ft ³	cubic feet	0.02831685	cubic meters	m ³
yd ³	cubic yards	0.7645549	cubic meters	m ³
Mass				
oz	ounces	28.34952	grams	g
lb	pounds	0.4535924	kilograms	kg
T	2000 pounds	0.9071847	metric tons	t
Temperature				
°F	Fahrenheit	$C = (F-32)/1.8$	Celsius	°C
Illumination				
fc	foot-candles	10.76391	lux	lx
fl	foot-lamberts	3.426259	candelas per square meter	cd/m ²
Force and Pressure or Stress				
lbf-ft	pounds-force foot	1.355818	newton meter	N·m
lbf	pounds force	4.448222	newtons	N
lbf/ft ² (psf)	pounds force per square foot	47.88026	pascals	Pa
lbf/in ² (psi)	pounds force per square inch	0.006894757	megapascals	MPa

TABLE 109.02-2 SI (METRIC) TO ENGLISH CONVERSION FACTORS

Symbol	When You Know	Multiply By	To Find	Symbol
Length				
µm	micrometers	0.03937	mils	mil
mm	millimeters	0.03937	inches	in
m	meters	3.28084	feet	ft
m	meters	1.093613	yards	yd
km	kilometers	0.62137	miles	mi
Area				
mm ²	square millimeters	0.00155	square inches	in ²
m ²	square meters	10.76391	square feet	ft ²
m ²	square meters	1.19599	square yards	yd ²
ha	hectares	2.4710437	acres	ac
m ²	square meters	0.000247	acres	ac
km ²	square kilometers	0.3861	square miles	mi ²
Volume				
mL	milliliters	0.033814	fluid ounces	fl oz
L	liters	0.264172	gallons	gal
m ³	cubic meters	35.31466	cubic feet	ft ³
m ³	cubic meters	1.30795	cubic yard	yd ³
Mass				
g	grams	0.035274	ounces	oz
kg	kilograms	2.204622	pounds	lb
t	metric tons	1.1023114	2000 pounds	T
Temperature				
°C	Celsius	F = 1.8C + 32	Fahrenheit	°F
Illumination				
lx	lux	0.09290304	foot-candles	fc
cd/m ²	candelas per square meter	0.29186352	foot-lamberts	fl
Force and Pressure or Stress				
N·m	newton meters	0.7375621	pounds-foot force	lbf ft
N	newtons	0.22480892	pound force	lbf
Pa	pascals	0.02088543	pounds force per square foot	lbf/ft ² (psf)
MPa	megapascals	145.03774	pounds force per square inch	lbf/in ² (psi)

109.03 Scope of Payment. Payment of the Contract Price is full compensation for all resources necessary to complete the Contract Item and maintain the Work. Assume liability for risk, loss, damage, or expense resulting from the Work. The Contract Price and Contract Time shall only be changed by written Change Order or as determined by the LPA in writing in accordance with the contract documents.

109.04 Compensation for Altered Quantities, Eliminated Items or Termination of the Contract for Convenience of the LPA. If the agreed quantities of contract items vary from the quantities in the Contract, the LPA will make payment at the original Contract unit prices for the agreed quantities of Work.

A. If an item is eliminated in accordance with [104.02.E](#) or the contract is terminated in accordance with [108.09](#) the LPA will pay the following in addition to that provided by [104.02.D](#):

1. Restocking charges supported by paid invoices and an additional 5 percent markup on the compensation for overhead and profit.

2. The cost of material transferred to the LPA in lieu of restocking or disposal. The allowed compensation is the paid invoice cost plus 15 percent markup, but no more than the unit bid price for the reference number involved.

3. Hauling costs, if not included in restocking charges, for returned material and for material delivered to the LPA.

B. If the project is terminated for convenience of the LPA, the LPA will negotiate compensation with the Contractor for actual costs incurred as a result of the termination.

109.05 Changes and Extra Work.

A. General. If the LPA revises the Contract under: [104.02](#), [105.07](#), [105.10](#), [105.13](#), [107.10](#), [107.14](#), [107.15](#), [108.09](#), [109.06](#), or [109.07](#), the Department will pay for changes and Extra Work with a Change Order using the sequence specified in [109.05.B](#) through [109.05.E](#).

In establishing the method of payment for contract changes or extra work orders, force account procedures shall only be used when strictly necessary, such as when agreement cannot be reached with the Contractor on the price of a new work item, or when the extent of work is unknown or is of such character that a price cannot be determined to a reasonable degree of accuracy. The reason or reasons for using force account procedures shall be documented.

Unless otherwise stated in [109.05](#), the compensation provided in [109.05.B](#) through [109.05.E](#) constitutes payment in full for all changes and Extra Work completed by original Contract Price, agreed unit price, agreed lump sum price, and for work performed on a force account basis, including:

1. Administration.
2. Superintendence.
3. Project and field office overhead.
4. Home office overhead.
5. Use of tools and equipment for which no rental is allowed.
6. Profit.
7. Taxes other than sales tax.

8. Premiums on insurance including additional premiums for Commercial General Liability Insurance required by [107.12.B](#) and any additional coverage carried by the Contractor or subcontractor, excluding pollution and railroad General Liability Insurance. The LPA will pay the Contractor's pollution and railroad liability insurance premiums, if required by the contract, by a separate Change Order for the cost of the premium without any markup. When the Contractors or subcontractors basic rate for General Commercial Liability Insurance required by [107.12.B](#) is greater than 5 percent of payroll, the LPA will pay directly without markup the portion of the premium in excess of 5 percent and provide copies of paid premiums.

Sales tax will not be allowed on any item for which tax exemption was obtained.

B. Negotiated Prices. Negotiated prices for changes and Extra Work shall be comparable to prices that would have resulted from a competitive bid contract. The Engineer and Contractor will negotiate agreed unit or lump sum prices using one or more of the following methods:

1. Original Contract prices for similar work but adjusted for:
 - a. increased or decreased material costs specified in [109.05.C.3](#).
 - b. increased or decreased labor costs specified in [109.05.C.2](#)
 - c. increased or decreased equipment costs specified in [109.05.C.4](#)

Adjustments of these prices for inflation or markup for subcontractor work is not allowed.

2. State-wide average unit price awarded for the item, LPA average unit price awarded for the item, or items as listed in the Department's annual "Summary of Contracts Awarded." These prices may be adjusted for inflation using factors issued by the [Office of Construction Administration](#). No markup for subcontractor work is allowed.

3. Average price awarded on three different projects of similar work and quantity. These prices may be adjusted for inflation using factors issued by the [Office of Construction Administration](#). No markup for subcontractor work is allowed.

4. Prices computed by the Office of Estimating.

5. Cost analysis of labor, material, equipment, and markups as allowed in [109.05.C](#).

6. For the cost of compensable delays as defined in [108.06](#), prepare a cost analysis as allowed by [109.05.D](#).

Provide proposed pricing and cost justification for changes or Extra Work within 5 business days after the LPA's request. The LPA will respond within 5 business days after receipt of the Contractor's proposal. The LPA and the Contractor can mutually agree to extend these 5-day time limits.

If the LPA negotiates with the Contractor but does not agree on a price adjustment, the Engineer may direct the Contractor to perform all or part of the revised Work under force account.

C. Force Account.

1. General. The Engineer may direct the Contractor to perform the revised Work under force account. Submit a written proposal and estimated costs for the Work, including the planned equipment, materials, labor, and a work schedule.

The LPA will pay the Contractor as specified in [109.05.C](#) as full compensation for performing the force account Work. The Project and Contractor personnel will document the labor and equipment used on the force account work on a Daily Force Account Record. At the end of each Workday, the Project and Contractor personnel will compare and sign the Daily Force Account Record. The LPA will make no force account payment before the Contractor submits an itemized statement of the costs for that work.

The Engineer will examine and, if found to be acceptable, approve all rates and costs submitted by the Contractor.

Provide the following content in itemized statements for all force account work:

- a. Name, classification, date, daily hours, total hours, rate, and amount for all labor.
- b. Designation, dates, daily hours, total hours of actual operation and idle time, [Blue Book](#) rate with reference or category, and amount for each unit of equipment and the applicable [Blue Book](#) hourly operating cost for each unit of equipment and invoices for all rental equipment. The designation includes the manufacturer's name or trademark, model number, and year of manufacture.
- c. Quantities of materials and prices.
- d. Transportation charges on materials, free on board (F.O.B.) at the job site.

e. Cost of workers' compensation insurance premiums, all applicable insurance premiums, unemployment insurance contributions, and social security tax and fees or dues required by a collective bargaining agreement. Express each of these items of cost as a percentage of payroll, except fees or dues, which should be expressed as a cost per hour.

f. Documentation showing payment for all surveying, professional, or similar specialized Work not normally a part of an LPA contract.

g. If materials are taken from Contractor's stock and original receipted invoices for the materials and transportation charges do not exist, provide an affidavit and certify all of the following:

- (1) The materials were taken from the Contractor's stock.
- (2) The quantity shown was actually used for the force account work.
- (3) The price and transportation costs represent the actual cost to the Contractor.

h. Documentation showing payment to trucking firms and owner-operators. Submit documentation showing owner-operations status. When the trucking is subject to prevailing wage, submit payroll and equipment usage records according to [109.05.C.1.a](#), [109.05.C.1.b](#), and [109.05.C.1.e](#).

i. Provide "receipted invoices" for all costs substantiated by an invoice.

If only part of the expenditure represented by an invoice is applicable to force account work, or if the invoice represents expenditure for more than one item of work, clearly indicate the actual amount of expenditure applicable to each item of work.

2. Labor. The LPA will pay the wages and fringe benefits currently in effect for each hour the Work is performed by all labor employed in the Work and all foremen in direct charge of the specific operation. The LPA will pay an additional 38 percent markup on these wages and benefits. "Fringe benefits" are the actual costs paid to, or on behalf of, workmen by reason of health and welfare benefits, pension fund benefits, or other benefits, when such amounts are required by prevailing wage laws or by a collective bargaining agreement or other employment contracts generally applicable to the classes of labor employed on the Project.

The LPA will pay the actual itemized cost, without markup, of the following payroll taxes and legally required insurances:

- a. Social Security Tax.
- b. Medicare Tax.
- c. Ohio Workers' Compensation Premiums.
- d. State and Federal Unemployment Insurance.
- e. Longshore and Harborworkers' Compensation Insurance for work from a barge or ship, or unloading material from a barge or ship.

Provide itemized statements in addition to the documentation requirements for all labor including the name, classification, date, daily hours, total hours, rate, and amount. If any person is paid more than the one rate, a separate listing shall be made for that person for each rate paid. Provide itemized statements for Ohio Workers' Compensation insurance premiums, all applicable insurance premiums, State and Federal Unemployment Insurance contributions, and Social Security Tax and fees or dues required by a collective bargaining agreement. Express each of these items of cost as a percentage of payroll, except fees or dues, which shall be expressed as a cost per hour.

Instead of itemizing the cost of Social Security Tax, Ohio Workers' Compensation, and State and Federal Unemployment Insurance, the Contractor may elect to receive as compensation for these

payroll taxes and premiums, an amount equal to 22 percent of the paid wages. If the Contractor pays fringes directly to the worker in lieu of paying into a fringe benefit program, then the LPA will treat these fringe payments as paid wages when calculating the allowed 22 percent compensation.

The LPA will pay, without markup, the actual itemized cost of fees and dues paid to labor unions or to business associations when they are based on payroll hours and required by a collective bargaining agreement.

The LPA will not pay for wages or benefits for personnel connected with the Contractor's forces above the classification of foreman that have only general supervisory responsibility for the force account work.

If the foreman or timekeeper is employed partly on force account work and partly on other work, the Contractor shall prorate the number of hours between the force and non-force account work according to the number of people on each task as shown on payrolls.

The LPA will pay the prevailing wage and fringe rates that apply to the Project for the classifications required for Extra Work. The Contractor must provide payroll records for pay rates higher than the prevailing wages and establish that the higher than prevailing rates are paid for original Contract Work. The LPA will pay for foremen and time keepers not covered by prevailing wages not more than the salaried rate they receive when engaged in original Contract Work.

The LPA will pay actual costs for subsistence and travel allowances when such payments are required by the collective bargaining agreement or other employment contracts applicable to the classes of labor employed on the Project. The LPA will not pay a percent markup on these costs.

3. Materials. The LPA will pay the Contractor's actual invoice costs, including applicable taxes and actual freight charges, for Engineer approved materials the Contractor uses in force account Work. The LPA will pay an additional 15 percent markup on these costs.

Freight or hauling costs charged to the Contractor and not included in unit prices shall be itemized and supported by invoices. The cost of owned or rented equipment used to haul materials to the project is not part of the materials cost. Such equipment, when used for hauling materials, shall be listed under cost of equipment.

Provide itemized statements in addition to the documentation requirements for all equipment including the quantity and price of each material and transportation charges free on board (F.O.B.) at the job site. Attach invoices to support the quantities of materials used, unit prices paid and transportation charges. If the Contractor uses materials from the Contractor's stock and original receipted invoices for the materials and transportation charges do not exist, the Department and the Contractor will agree on a price that represents the actual cost to the Contractor. Provide an affidavit and certify all of the following:

- a. The materials were taken from the Contractor's stock.
- b. The quantity shown was actually used for the force account work.
- c. The price and transportation costs represent the actual cost to the Contractor.

Do not incorporate materials into the Work without a price agreement.

4. Equipment.

a. General. The LPA will pay the Contractor's costs for equipment the Engineer deems necessary to perform the force account work for the time directed by the Engineer or until the Contractor completes the force account Work, whichever happens first. The LPA will pay the Contractor the established rates for equipment only during the hours that it is operated, except as

otherwise allowed elsewhere in these Specifications. The LPA will pay for non-operating hours at the idle equipment rate as specified in [109.05.C.4.c](#). Report equipment hours to the nearest 1/2 hour. The established equipment rates in these Specifications include compensation for overhead and profit except as otherwise specified.

The LPA will pay for use of Contractor-owned equipment the Engineer approves for force account Work at established rates. The LPA will pay the rates, as modified in [109.05.C.4.b](#), given in the [Equipment Watch Cost Recovery](#) (formerly Rental Rate [Blue Book](#)), by EquipmentWatch, a division of Penton Business Media, Inc.

Provide, and the Engineer will confirm, the manufacturer's ratings and manufacturer-approved modifications required to classify equipment for rental rate determination. For equipment with no direct power unit, use a unit of at least the minimum recommended manufacturer's rating.

The LPA will not pay rental for small tools or equipment that show a daily rate less than \$5.00 or for unlisted equipment that has a value of less than \$400.

Tool trucks will be allowed for compensation if they are used at the force account site. Only the tools used from the tool truck will be allowed for compensation. Tools in the tool truck that are not used in the force account work will not be compensated. A tool trailer that remains at the Contractor's office or yard will not be allowed on the force account work. Tool trailers that are taken to the force account site will be allowed for compensation along with the tools used on the force account work that were taken from the trailer.

Treat traffic control devices used in Maintaining Traffic and owned by the Contractor as owned equipment. Allowed rates for common traffic control devices and concrete barrier that are not listed in the [Blue Book](#) will be as determined by the LPA.

Use Engineer approved equipment in good working condition and providing normal output or production. The Engineer may reject equipment not in good working condition or not properly sized for efficient performance of the Work.

For each piece of equipment used, whether owned or rented, provide the Engineer with the following information:

- (1) Manufacturer's name or trademark.
- (2) Equipment type.
- (3) Year of manufacture.
- (4) Model number.
- (5) Type of fuel used.
- (6) Horsepower rating.
- (7) Attachments required, together with their size or capacity.
- (8) All further information necessary to determine the proper rate.
- (9) Dates, daily hours, total hours of actual operation and idle time,
- (10) [Blue Book](#) rate with reference or category,
- (11) Amount
- (12) Applicable [Blue Book](#) hourly operating cost
- (13) Invoices for all rental equipment.

b. Hourly Owned Equipment Rates. The base rate for the machine and attachments represent the major cost of equipment ownership, such as depreciation, interest, taxes, insurance, storage, and major repairs. The hourly operating rate represents the major costs of equipment operation, such as fuel and oil lubrication, field repairs, tires, expendable parts, and supplies.

For all equipment used on force account work, determine, and have the LPA confirm, the hourly owned equipment rates as follows:

$$\text{HOER} = [\text{RAF} \times \text{ARA} \times (\text{R} / 176)] + \text{HOC}$$

Where:

HOER = hourly owned equipment rate

RAF = regional adjustment factor shown in the [Blue Book](#)

ARA = age rate adjustment factor shown in the [Blue Book](#)

R = current [Blue Book](#) monthly rate

HOC = estimated hourly operating cost shown in the [Blue Book](#)

However, compensation for equipment normally used on a 24 hours per day basis will not exceed the monthly rate plus adjustments and operating costs.

The rate adjustment factor assigned to any attachment will be the yearly factor as determined for the base equipment.

When multiple attachments are included with the rental equipment, only the attachment having the highest rental rate will be eligible for payment, provided that the attachment has been approved by the Engineer as being necessary to the force account Work.

When a piece of owned equipment is not listed in the [Blue Book](#), use the rate for similar equipment found in the [Blue Book](#) or use 6 percent of the purchase price as the monthly rate (R) and add the hourly operating rate found in the [Blue Book](#) for similar equipment of the same horsepower.

For equipment brought to the Project exclusively for force account work and on the Project for less than a month, multiply the monthly rate (R) by the factor listed below:

TABLE 109.05-1

Working Hours	Factor
Less than or equal to 8.0	2.00
8.1 to 175.9	2.048 - (hours/168)
176 or greater	1.00

The term “WORKING HOURS,” as used in Table [109.05-1](#), includes only those hours the equipment is actually in operation performing force account work; apply the factor, as determined above, to these actual working hours only. Calculate compensation for any idle time according to [109.05.C.4.c](#) without application of the factor.

The LPA will pay as working equipment for the entire Workday equipment used intermittently during the Workday. The following criteria qualify for intermittently used equipment:

(1) Equipment dedicated to the force account exclusively all day and not used on bid work.

(2) Equipment works before and after the intermittent idle period and its total working time during the Workday is at least 2 hours.

Equipment that is captive to the force account work (i.e. it must remain at the force account site), but does not qualify for intermittently used owned equipment, is paid as idle equipment according to [109.05.C.4.c](#) for the time it is not working.

c. Hourly Idle Equipment Rate. For equipment that is in operational condition, on site, and necessary for force account Work, but is idle, the LPA will pay an hourly idle equipment rate. The procedure to determine the hourly idle equipment rate for Contractor owned equipment is as follows:

$$\text{HIER} = \text{RAF} \times \text{ARA} \times (\text{R} / 176) \times (1/2)$$

Where:

HIER = Hourly idle equipment rate.

RAF = Regional adjustment factor shown in the [Blue Book](#).

ARA = Age rate adjustment factor shown in the [Blue Book](#).

R = Current [Blue Book](#) monthly rate.

If rented equipment necessary for force account work is idle, the LPA will pay the Contractor for the actual invoiced rates prorated for the duration of the idle period. The actual invoiced rates must be reasonably in line with the [Blue Book](#) rates and approved by the Engineer. The LPA will pay a 15 percent markup for overhead and profit for the actual invoiced rates during the idle period.

The LPA will not pay idle owned equipment costs for more than 8 hours in a 24-hour day or 40 hours in a week.

The LPA will not pay for inoperable equipment.

The Engineer may order specific equipment to the site up to 5 days before its planned usage. If this equipment is not used for other work, the LPA will pay for it as idle equipment until used.

The LPA will pay for the cost of idle owned or rented equipment when the Work was suspended for the convenience of the State. The LPA will not pay the cost of idle equipment when the Work was suspended by the Contractor for the Contractor's own reasons.

The LPA will only pay for the number of Calendar Days during the existence of the suspension. The LPA will not compensate the Contractor for days that the Engineer determined were lost to weather.

The LPA will only pay for equipment physically located at the Project site that was received to prosecute the scheduled work during the delay.

Compensation for idle equipment will stop at the completion of the force account Work or at the end of the suspension of Work.

d. Rented Equipment. The LPA will pay a 15 percent markup for overhead and profit for all rented equipment, its corresponding [Blue Book](#) hourly operating costs, and State and Local sales taxes.

(1) Equipment Rented Solely for Force Account Work. If the Contractor rents or leases equipment from a third party exclusively for force account Work, the LPA will pay the actual invoiced amount. The actual invoiced rates must be reasonably in line with the [Blue Book](#) and approved by the Engineer. The LPA will pay a 15 percent markup for overhead and profit for all rented equipment paid for by the actual invoices. Add the [Blue Book](#) hourly operating cost to the marked up actual invoiced rates.

(2) Equipment Rented for Original Contract Work, but Used for Force Account Work. If the Contractor uses rented equipment currently on the Project for original Contract Work to perform force account Work, then determine the hourly outside-rented equipment rate as follows:

$$\text{HRER} = (\text{HRI} \times 115\%) + \text{HOC}$$

Where:

HRER = hourly rented equipment rate

HRI = hourly rental invoice costs prorated for the actual number of hours that rented equipment is operated solely on force account work. Use a monthly invoice rate

divided by 176, a weekly invoice rate divided by 40, or a daily invoice rate divided by 8.

HOC = hourly operating cost shown in the [Blue Book](#)

The LPA will not compensate for rental rates that exceed the [Blue Book](#) rates unless approved in advance of the Work by the Engineer.

e. Moving of Equipment. The LPA will also pay for the time required to move needed equipment to the location of the force account work and to return it to its original location. The LPA will pay for loading and transportation costs instead of moving time if equipment is moved by means other than its own power. Moving time back to the original location or loading and transportation costs will not be allowed if the equipment is used at the site of the force account work on contract items or related work.

The LPA will consider the actual cost of transferring the equipment to the Project and returning it to the original location as an additional expense and pay for it as specified, for equipment moved on the Project exclusively for force account work.

The Engineer will confirm the original location of the equipment before the Contractor moves and uses it for force account work.

If the equipment is transported by a common carrier, the allowance is the invoiced amount paid for the freight plus 15 percent. However, if the Contractor's forces transport the equipment, the allowable compensation will be [Blue Book](#) rate of the hauling unit and hourly [Blue Book](#) operating cost plus the driver's wages and the cost of loading and unloading the equipment calculated according to [109.05.C.2](#).

5. Foreman's Transportation. The LPA will pay the [Blue Book](#) rate for every hour the foreman's truck is on the force account site or moving to or from the site. This rate includes equipment cost, fuel and lubricants, overhead, profit, and mobile phone or two-way radios.

6. Subcontract Work. For Work performed by an approved subcontractor, the LPA will pay an amount to cover administrative costs of 8% on the first \$10,000 of work and 5% for work in excess of \$10,000 as provided in [109.05.C.4](#) through [109.05.C.5](#). No additional mark-up is allowed for work of a sub-subcontractor or trucking services employed by a subcontractor.

7. Final Adjustment to Premium for Contract Bonds. The final bond premium amount for the payment and performance bonds will be computed based on the actual final contract value. For the purpose of computing a bond premium adjustment the actual final contract value is defined as the whole sum of money, excluding any bond premium adjustment, which is passed from the LPA to the Contractor as a result of the completion of the Work. If the actual final contract value is different from the original contract value, the premium shall be adjusted accordingly; either by refund of part of the original bond premium by the Contractor if the original contract value is larger than the actual final contract value; or by payment of additional bond premium by the LPA if the original contract value is smaller than the actual final contract value. Additional payment by the LPA or refund by the Contractor will be based on the difference between the invoiced bond premium for the original contract value and the invoiced bond premium for the actual final contract value without any markup. A final bond premium adjustment will not be made when the actual final contract value differs from the original contract value by less than \$ 40,000.00.

8. Trucking.

a. Trucking firms and owner operators not subject to prevailing wage will be paid at the invoiced cost plus 8% on the first \$10,000 of trucking and 5% for trucking in excess of \$10,000 to cover administrative costs.

b. Trucking that is subject to the prevailing wage law will be compensated according to 109.05.C.1, 109.05.C.2, 109.05.C.4, 109.05.C.6, and 109.05.C.10.

Provide documentation showing payment to trucking firms and owner-operators and owner-operations status. When the trucking is subject to prevailing wage, submit payroll and equipment usage records according to [109.05.C.2](#) and [109.05.C.4](#).

9. Professional and Specialized Work. The following work, when performed by a firm hired by the Contractor, is paid at the reasonable and fair market invoiced cost plus 8% on the first \$10,000 of work and 5% for work in excess of \$10,000.

a. Surveying.

b. Engineering design.

c. Specialized work that is not normally part of a LPA Contract and is not normally subject to prevailing wage.

d. Installation, periodic maintenance, and removal of traffic control devices under [Item 614](#) performed by a traffic control service or rental company, provided the workers are not on the Project full-time. Maintenance of Traffic services performed by LEO.

e. Other professional or specialized work not contemplated at the time of Bid.

Provide documentation showing payment for professional and specialized Work.

10. Payment for Force Account Work. Submit an analysis of estimated cost prepared in accordance with [109.05.C](#) for work that will be performed on a force account basis. Attach an original affidavit to the analysis stating:

“Labor rates shown are the actual rates paid for labor, unit prices for materials and rates for owned and rented equipment have been estimated on the basis they are not in excess of those charged in the area in which the work will be performed.”

The Engineer will process an Estimated Cost of Force Account (ECFA) if the amount of the force account work is likely to be greater than \$100,000 and is expected to take more than two weeks to complete. The Engineer will process an Actual Cost of Force Account (ACFA) to make any necessary adjustment between the ECFA and the final itemized costs for the force account work.

For force account work estimated to be less than \$100,000 and anticipated to require less than two weeks to perform, the Engineer will process an Actual Cost of Force Account (ACFA) at the conclusion of the work.

Submit biweekly itemized statement of costs prepared from the Daily Force Account Records to the Engineer as the work is being performed. The Engineer will process estimates as the force account work is performed. Payment will only be made upon receipt of the Contractor’s itemized statement of costs.

Upon conclusion of the work performed by an ECFA or work performed by an ACFA submit an itemized statement of the actual costs prepared from the Daily Force Account Record Submit a compact disk (CD), labeled with the Contractor’s name and the project number, and a hard copy of the

“Electronic Force Account.” An “Electronic Force Account” template can be downloaded from the following website:

www.dot.state.oh.us/divisions/constructionmgt/admin/pages/default.aspx

The Engineer may approve an alternative electronic template provided all calculations and printouts are equivalent to those generated by the “Electronic Force Account” template.

Attach an original affidavit to the hard copy stating:

“The name, classification, total hours worked and rates paid each person listed on the Summary of Actual Cost are substantiated by actual records of persons employed on the force account work. All unit prices for materials and rates for owned and rented equipment listed on the Summary of Actual Costs are substantiated by actual records of materials and equipment actually used in performance of the force account work and the price of any owned equipment not previously agreed upon does not exceed prices charged for similar equipment in the area in which the work was performed.”

Daily Force Account Records signed by both the LPA and Contractor will govern over other LPA and Contractor records subject to the following:

a. When the Contractor is subject to a Union Contract that requires a minimum number of paid hours, the compensation will be for the verified contract minimum hours.

b. Material quantity disagreements will be resolved by field measurements of the installed quantities or the Engineer’s estimate of the amount of temporary or un-measurable material used. The Engineer may also review and consider the Contractor’s material invoices and material certifications to make the final determination.

In the event the Contractor declines to sign the Daily Force Account Record, the LPA’s records shall govern. Any resulting dispute must be pursued in accordance with 108.02.G.

D. Delay Costs.

1. General. If the LPA agrees that it has caused a delay, the LPA will pay for the costs specified in [109.05.D](#) as allowed by [108.06.D](#), unless these costs have been previously paid as listed in [109.05.B](#) or [109.05.C](#). Such payment constitutes full compensation for any and all delay costs

The LPA will make no payment for delays occurring during the period from December 1 to April 30 unless the Contractor’s approved progress schedule depicts critical Work occurring throughout this period.

The LPA will not pay for delay costs until the Contractor submits an itemized statement of those costs. Provide the content specified in [109.05.C.1](#), for the applicable items in this statement and as follows:

- a. Proof of cost of Superintendent, or other project staff salaries, wages, and payroll taxes and insurance.
- b. Proof of cost of office rent, utilities, land rent, and office supplies.
- c. Proof of escalated cost for labor and material.
- d. Proof of material storage costs.

2. Allowable Delay Costs

a. Extended Labor. Compute labor costs during delays as specified in [109.05.C.4](#) for all non-salaried personnel remaining on the Project as required under collective bargaining agreements or for other Engineer-approved reasons.

b. Escalated Labor. To receive payment for escalated labor costs, demonstrate that the LPA-caused delay forced the Work to be performed during a period when labor costs were higher than planned at the time of Bid. Provide adequate support documentation for the costs, allowances, and benefits specified in [109.05.C.4](#). The LPA will pay wages and fringes with a 20 percent mark-up to cover administrative costs.

c. Idle Equipment or Equipment Demobilization. The LPA will pay the Contractor according to [109.05.C.4.c](#) for idle equipment, other than small tools, that must remain on the Project during the delays. The LPA will pay the Contractor’s transportation costs to remove and return equipment not required on the Project during the delays. No other equipment costs are recoverable as a result of delay.

d. Material Escalation or Material Storage. The LPA will pay the Contractor for increased material costs or material storage costs due to the delay. Obtain the Engineer’s approval before storing materials due to a delay. Payment will be based upon the accepted quantity of work performed during the period for which escalated costs have been approved. The LPA will pay increased material costs with an 8 percent mark-up to cover administrative costs and any material waste inherent to the Work.

e. Field Overhead. The LPA will pay any Contractor or subcontractor for field overhead costs which include the cost of supervision, field office and office supplies, and utilities for which payment is not provided for in [109.05.D.2.f](#), during a delay period provided all of the following criteria are met:

(1) The Contractor or subcontractor has incurred an excusable, compensable delay that delays the Work at least 10 Calendar Days beyond the original Completion Date. These days are cumulative throughout the project.

(2) The delay for which payment of field overhead is sought is only due to delays defined in [108.06.D.2](#), [108.06.D.3](#), [108.06.D.5](#) or for delays due to revised Work as specified in [104.02.B](#) or [104.02.F](#).

The LPA will pay the salary and fringes plus a 5 percent markup for field personnel identified in Table [109.05-4](#).

TABLE 109.05-4

Original Contract Amount	Field Personnel
Up to \$5,000,000	One Superintendent
\$5,000,001 to \$50,000,000	One Superintendent, One Assistant Superintendent or One Engineer, One Clerk
Over \$50,000,000	One Superintendent, One Assistant Superintendent, One Engineer, One Clerk

Superintendent’s transportation is compensable at the same rate allowed for foreman’s transportation in Section [109.05.C.5](#), which includes the cost of mobile communication devices. The allowed hours are when the superintendent is at the project site.

Superintendent’s subsistence, provided this is the company’s terms of compensation to such employees, as documented by the Contractor’s written company policy or contracts with their employees.

The Contractor's or subcontractor's field office costs include field office trailers, tool trailers, office equipment rental, temporary toilets, and other incidental facilities and supplies. Compute these costs on a Calendar Day basis. Owned trailers are paid at the [Blue Book](#) rate. Rented trailers are paid at the invoiced cost plus a 15 percent markup. Rented office space, toilets, and office equipment are allowed a 5 percent markup. Purchased office supplies are allowed a 5 percent markup.

Office utilities include, but are not limited to, telephone, electric, water, and natural gas. Compute these costs on a Calendar Day basis and allow a 5 percent markup.

f. Home Office Overhead. The LPA will pay the Contractor for home office overhead, unabsorbed home office overhead, extended home office overhead, and all other overhead costs for which payment is not provided for in [109.05.D.2.e](#), including overhead costs that would otherwise be calculated using the Eichleay formula or some other apportionment formula, provided all of the following criteria are met:

(1) The Contractor has incurred an excusable, compensable delay that delays the Work at least 10 Calendar Days beyond the original Completion Date. These days are cumulative throughout the project.

(2) The delay for which payment of home office overhead is sought is only due to delays defined in [108.06.D.2](#), [108.06.D.3](#) and [108.06.D.5](#).

Any subcontractor that has approved C-92's for subcontracted work totaling \$4,000,000 or more is eligible for reimbursement of home office overhead provided the criteria set forth in [109.05.D.2.f.\(1\)](#) and [109.05.D.2.f.\(2\)](#) are met.

Payment will be made for every eligible day beyond the original contract completion date at the rate determined by [109.05.D.2.f.\(1\).i](#). Payment for eligible days occurring during an unanticipated construction period will be calculated in accordance with [109.05.D.2.f.\(1\).ii](#). Payment for eligible days occurring during an unanticipated winter period will be calculated in accordance with [109.05.D.2.f.\(1\).iii](#).

(i) Home Office Overhead Daily Rate

Calculate the home office overhead daily rate using the following formula:

$$\text{Daily HOOP} = (A \times C)/B$$

Where:

- A = original contract amount
- B = contract duration in Calendar Days
- C = value from [Table 109.05-5](#)

TABLE 109.05-5

Original Contract Amount	C
Up to \$5,000,000	0.08
\$5,000,001 to \$25,000,000	0.06
Over \$25,000,000	0.05

Daily HOOP = home office overhead daily rate

Contract duration term, B, includes every Calendar Day from the execution of the Contract, unless otherwise specified by the PRC and/or CPE, to the original Contract Completion Date.

When the Contractor requests home office overhead compensation for a subcontractor, use the above formula to calculate the subcontractor's Daily HOOP; however, in the subcontractor calculation, A is equal to the subcontractor's portion of the original contract amount as determined by the sum of all approved C-92's issued for the subcontracted work.

(ii) Home Office Overhead Payment for an Unanticipated Construction Period

Calculate the home office overhead payment for an unanticipated construction period occurring between May 1 and November 30 using the following formula:

$$\text{CP HOOP} = \text{Daily HOOP} \times D$$

Where:

D = sum of all excusable, compensable delays in Calendar Days minus the sum of all delays due to [108.06.D.1](#) and [108.06.D.4](#) in Calendar Days

Daily HOOP = daily home office overhead rate

CP HOOP = home office overhead payment for an unanticipated construction period occurring between May 1 and November 30

The excusable, compensable delay term, D, is the additional, unanticipated extended period for work performed between May 1 and November 30 in Calendar Days.

(iii) Home Office Overhead Payment for an Unanticipated Winter Period

Calculate the payment for home office overhead for an unanticipated winter period occurring between December 1 and April 30 using the following formula:

$$\text{WP HOOP} = \text{Daily HOOP} \times F \times D/E$$

Where:

D = sum of all excusable, compensable delays in Calendar Days minus the sum of all delays due to [108.06.D.1](#) and [108.06.D.4](#) in Calendar Days

E = sum of all excusable, compensable delays in Calendar Days plus the sum of all excusable, non-compensable delays in Calendar Days

F = 151 for a non-leap year or 152 for a leap year

Daily HOOP = daily home office overhead rate

WP HOOP = home office overhead payment for an unanticipated winter period occurring between December 1 and April 30

Payment for Home Office Overhead for an unanticipated winter period will not be made when the value of the remaining work is below the lesser of \$500,000.00 or 10 percent of the estimated final contract value.

(iv) Total Home Office Overhead Payment

Calculate the total home office overhead payment using the following formula:

$$\text{Total HOOP} = \text{CP HOOP} + \text{WP HOOP}$$

Where:

CP HOOP = home office overhead payment for an unanticipated construction period occurring between May 1 and November 30

WP HOOP = home office overhead payment for an unanticipated winter period occurring between December 1 and April 30

Total HOOP = total home office overhead payment

g. Subsistence and Travel Allowance. The LPA will pay costs for subsistence and travel allowances for labor that must remain on the Project during the delays, when such payments are required by the collective bargaining agreement or other employment contracts applicable to the classes of labor employed on the project. Overnight lodging will be reimbursed if the person is at a location greater than forty-five miles from their residence up to a maximum of \$106 per day. Meals and incidental expenses will be reimbursed up to a maximum of \$56 per day. The LPA will not pay a percent markup on these costs.

E. Changes in Materials. Changes in material specifications that result in increased cost to the Contractor are compensated by lump sum adjustment to the reference number. The allowed compensation is equal to the invoice supported material cost increase plus 15 percent markup for profit and overhead.

Material cost savings resulting from a specification change shall be credited to the project by a lump sum adjustment to the reference number plus a 15 percent markup if the originally specified material has not been ordered.

If the original material was ordered before the Contractor was informed of the change, the savings markup allowed is 2.5 percent in order to exclude profit on the original bid price and pay only for incurred overhead.

109.06 Directed Acceleration. The PRC and/or CPE may order the Contractor to accelerate the Work to avoid delay costs or to complete the Project early. The PRC and/or CPE and the Contractor will negotiate acceleration costs.

109.07 Inefficiency. The LPA will compensate the Contractor for inefficiency or loss of productivity resulting from [104.02](#) Revisions to the Contract Documents. Use the Measured Mile analysis comparing the productivity of work impacted by a change to the productivity of similar work performed under un-impacted conditions to prove and quantify the inefficiency.

109.08 Unrecoverable Costs. The Contractor is not entitled to additional compensation for costs not specifically allowed or provided for in [109.05](#) including, but not limited to, the following:

- A. Loss of anticipated profit.
- B. Consequential damages, including loss of bonding capacity, loss of bidding opportunities, insolvency, and the effects of force account work on other projects, or business interruption.
- C. Indirect costs.
- D. Attorney's fees, claim preparation expenses, and the costs of litigation.

109.09 Estimates. If satisfactory progress is being made, the Contractor will receive monthly payments equaling the Work and materials in place. The monthly payment is approximate, and all partial estimates and payments are subject to correction in the Final Estimate and payment. Payment for Work and materials shall not, in any way, prevent later rejection when defective Work or material is discovered, or constitute acceptance under [109.11](#) or [109.12](#). Any pay item deficient in material approval can be withheld for payment on an estimate.

Except for estimates generated during Project finalization, the LPA will not pay an estimate until the Contractor certifies to the Engineer that the work for which payment is being made was performed in accordance with the contract. Certification will be made on forms provided by the LPA.

The LPA may pay estimates twice each month if the Engineer concludes the amount of work performed is sufficient.

No estimate or payment shall be construed as acceptance of defective Work or improper materials.

The LPA will not pay the adjusted final estimate until the Contractor remedies all defective Work and accepted Work damaged by the Contractor's operations.

Interest will be paid in accordance with [ORC 126.30](#) when warranted.

109.10 Payment for Delivered Materials. The LPA will pay, up to 75 percent of the applicable contract item, for the invoiced cost of the delivered and approved materials before they are incorporated in the Work, if the approved materials are delivered, accepted, and properly stored on the project or stored in acceptable storage places in the vicinity of the Project.

The LPA will pay for the cost of approved materials before they are incorporated in the Work when asked by the Contractor, if the Engineer determines that it is not practical to deliver the material to the Project site. This provision applies only to bulky materials that are durable in nature and represent a significant portion of the project cost, such as aggregates, steel, and precast concrete. The Department will pay for un-fabricated structural steel if the following requirements are met:

- A. The Contractor has provided both the Engineer and the [Office of Materials Management](#) an itemized invoice from the steel mill for the steel for which reimbursement is requested
- B. Project structural Steel design plans are complete with no forthcoming revisions. For design build projects, Contractor accepted show drawings per [501.04](#), will need to be provided.
- C Contractor accepted certified test data for all steel in question along with mill shipping notices have been received by the [Office of Materials Management](#) per [501.06](#).
- D. The steel is properly stored to allow inspection by the [Office of Materials Management](#). It shall also be properly set apart from other material and identified as belonging to ODOT.
- E. The Contractor will provide the Engineer a written statement that under [106](#), the Contractor is responsible for the steel that has been paid for until the actual steel is erected and accepted in the field.
- F. Payment shall only be authorized after all the aforementioned documentation has been received by the [Office of Materials Management](#) and the steel has been inspected by the [Office of Materials Management](#) to verify that all steel listed in the itemized invoice has been received by the fabricator and properly stored. The amount to be paid shall be equivalent to the itemized invoice from the steel mill, but shall not exceed 50% of the bid price for the structural steel.

The LPA will not pay delivered materials on small warehouse items or for plant materials.

109.11 Partial Acceptance. Upon completion of a portion of the Work, the Contractor may request acceptance of a completed portion of the Work.

- A. An inspection may be performed on a completed portion of the project roadway section provided:
 - 1. All safety items are in place including permanent pavement markings.
 - 2. Traffic is in its final pattern.
 - 3. A completed portion of the project constitutes a completed geographic section of the project or a direction of traffic on a divided highway.
 - 4. Is in accordance with other contract provisions.
- B. An inspection may be performed on a completed bridge provided:
 - 1. All work on the bridge and approaches are complete, including all safety items and permanent pavement markings.
 - 2. The Contractor will not return to the bridge for any work except as allowed in 4.

3. Traffic is in its final pattern.
4. Painting of structural steel is either completed or scheduled to be performed.
5. Is in accordance with other contract provisions.

The Final Inspector will grant written partial acceptance for that portion of the Work or reject the Contractor's request. Such written partial acceptance will designate what portion of the Work is accepted, the date of acceptance, and the warranty provisions started by the partial acceptance.

Partial acceptance will relieve the Contractor of maintenance responsibility for the designated portion of the Work. This does not relieve the Contractor of responsibility to correct defective Work or repair damage caused by the Contractor or waive any other remedy to which the LPA is entitled at law or in equity.

109.12 Final Acceptance.

A. Final Inspection. The Department will perform a Final Inspection for the sole purpose of relieving the Contractor of maintenance responsibility for the Work.

The Final Inspection shall be a limited visual review of the Work and shall only serve as the LPA's verification that the Work appears substantially complete. Final Inspection does not waive any available rights or remedies of the LPA, nor divest the Contractor of any responsibility for compliance with the contract or liability for damages.

Notify the Engineer when the Project is complete and all of the Engineer's punch list items are complete. If the Engineer agrees the Project is complete, then within 10 business days the District Final Inspector will inspect the Work and categorize it as one of the following:

1. Unacceptable or not complete.
2. Substantially complete with punch list items found by the Final Inspector.
3. Substantially complete.

If the Final Inspector finds the Work substantially complete or substantially complete with punch list items, then the Contractor's maintenance responsibilities end on the day of the Final Inspection, except for any maintenance related to unfinished punch list items. This does not relieve the Contractor of responsibility to correct defective Work or repair damage caused by the Contractor or waive any other remedy to which the LPA is entitled at law or in equity. The Final Inspector will issue a Final Inspection Report that will document the findings of the inspection and start any warranty period.

B. Punch List. The Final Inspector will issue to the Contractor a written punch list of work required as a condition of acceptance. For project involving multiple public agencies, the Final Inspector will receive and compile punch lists from all agencies that have authority to provide one prior to issuing the Department's punch list. The Final Inspector's punch list will stipulate a reasonable time to complete the required Work. Failure of the Contractor to complete the punch list items by the stipulated time will result in the assessment of fifty percent of the Liquidated Damages according to [108.07](#) for each Calendar Day for every day beyond the stipulated time the punch list work remains incomplete and beyond the revised Completion Date.

C. Finalization. The Contractor shall accept the final quantities as determined by the Engineer or provide a written notice indicating the reason for disagreement within 30 Calendar Days of receiving the Engineer's list of final quantities. The prescribed 30 Calendar Day period can be modified by mutual agreement of the Contractor and the PRC and/or CPE. If no notice of disagreement is received, then the final payment will be based on the Engineer's list of final quantities.

Supply all documents necessary for Project finalization within 60 Calendar Days from the date that the Work is physically complete. These documents include:

1. Delinquent material certifications.
2. Delinquent certified payrolls or required revised payrolls.
3. Wage affidavit required by [ORC Chapter 4115](#) on projects without any Federal funding.
4. Delinquent force account records.
5. If applicable, DBE affidavits.
6. Any other document required to complete finalization of the project.

Failure to submit these acceptably completed documents will result in an administrative fee of \$100 per Calendar Day for every day that any of the required documents remain delinquent, starting 30 Calendar Days after receipt of written notification from the Engineer of a document deficiency.

D. Final Payment. Final payment is based on:

1. The agreed final quantities or as determined by the Engineer if agreement is not possible, no compensation for unauthorized work is allowed.
2. Finding of substantial completion by the Final Inspector.
3. Receipt of acceptable finalization documents.
4. Contractor certification that the Work was performed in accordance with the contract.

E. Completion of Contract and Continuation of Contractor's Responsibility. The Contract is complete, except for items covered by the required bonds, when the Contractor receives final payment. The PRC or if applicable, the CPE, will issue a letter confirming completion of the contract, noting any exception as provided in Items [659](#) and [661](#) and any warranty. Neither Completion of the Contract nor substantial completion relieves the Contractor of any responsibilities to properly perform or correct the Work or to repair damage or waives any remedies to which the LPA is entitled at law or in equity.

