

City of Mentor

**BID SET**

**SUPPLY, DELIVER AND START-UP A  
GOLF COURSE IRRIGATION PUMP  
STATION FOR BLACK BROOK GOLF  
COURSE**

---

**Prepared under the supervision of  
Brian E. Vinchesi, Design Engineer  
Irrigation Consulting, Inc.  
Date: June, 2023**

**Approved By:  
Kenn Kaminski, Director of Parks and  
Recreation**

## **CITY OF MENTOR OFFICIALS**

### **ADMINISTRATION**

Kenneth J. Filipiak, City Manager

David W. Malinowski, Finance Director

Joseph P. Szeman, Law Director

David A. Swiger, City Engineer

Matthew Schweikert, Director of Public Works

Kenneth Kaminski, Director of Parks and Recreation

Kevin Malecek, Economic Development Director

Kathleen Mitchell, Planning Director

Ken Gunsch, Chief of Police

Robert Searles, Fire Chief

### **MEMBERS OF COUNCIL**

Matthew E. Donovan, President

Scott Marn, Vice President

Sean P. Blake

Janet A. Dowling

Mark Freeman

John A. Krueger

Ray Kirchner

Julie Schiavoni, Clerk of Council

## I. LEGAL NOTICE

The CITY OF MENTOR will receive sealed bids at the Purchasing Office, 8500 Civic Center Blvd., Mentor, Ohio 44060, until 1:00 P.M. (local time) on Friday, August 11, 2023 for:

### **Supply, Deliver and Start-up of a Golf Course Irrigation Pump Station for Black Brook Golf Course**

Bids must be in accordance with specifications advertised on the City of Mentor website: [www.cityofmentor.com/category/rfp](http://www.cityofmentor.com/category/rfp) or RFP's will be available for pick-up at the Purchasing Office for the cost of printing. Bidders are responsible for checking for Addenda and obtaining any from the website.

Kenneth Filipiak, City Manager  
([cityofmentor.com/legal notices](http://cityofmentor.com/legal%20notices))

NEWS HERALD:  
PUBLISH DATES:

July 28, 2023  
August 4, 2023

THE CITY OF MENTOR  
8500 CIVIC CENTER BOULEVARD  
MENTOR, OH 44060

SPECIFICATIONS AND BID FORMS FOR:  
**Supply, Deliver and Start-up of a Golf Course Irrigation Pump Station for  
Black Brook Golf Course**

CONTENTS:

I. LEGAL NOTICE ..... Page LN-1  
II. INSTRUCTIONS TO BIDDERS ..... Pages IB-1/4  
III. FORM OF NONCOLLUSION AFFIDAVIT ..... Page FNA-1  
IV. BUSINESS ENTITY RESOLUTION ..... Page BER-1  
V. BIDDERS ACCEPTANCE TO CONTRACT .....Pages BAC 1 - 6  
VI. SPECIFICATIONS .....Pages 7 - 39  
VII. PROPOSAL-CONTRACT FORM ..... Page 40 - 41  
VIII. DRAWING ..... P-1.0

CITY OF MENTOR  
PURCHASING OFFICE

**DATE: Friday, August 11, 2023**

**1:00 P.M.**

**ALL BIDS SUBMITTED MUST INCLUDE THE REQUIRED BID DEPOSIT AND  
A PROPERLY EXECUTED BIDDERS ACCEPTANCE TO CONTRACT (BAC-1).**

## II.

### INSTRUCTIONS TO BIDDERS

*The Instructions to Bidders governs, except where amended by the Specifications.*

The Bidder is responsible for reading and understanding all items herein:

1. Except as otherwise provided herein, the Instructions to Bidders, Proposal-Contract Form, and all specifications, drawings and other documents referred to herein shall be a part of the contract.

2. DEFINITIONS:

- A. The term "Bidder" or "Contractor" shall mean the corporation, partnership or individual proposing or under contract to furnish the material, labor, and/or equipment listed in the Specifications.
- B. The term "City" shall mean the City of Mentor, Ohio.
- C. "Calendar Day" shall mean every day shown on the calendar.
- D. "City Manager" shall mean the Mentor City Manager or his duly authorized representative.

3. PROPOSAL: To be entitled to consideration, a proposal must be made in accordance with the following instructions:

- A. Preparation: Each proposal shall be submitted on the forms furnished by the City. All signatures shall be clearly and legibly written in long hand. No oral, facsimile or telephonic proposal or modifications will be considered. Each proposal shall show the breakdown for each item as directed on the Proposal-Contract Form. All proposals shall be considered informal which contain items not specified in the Proposal-Contract Form.

Prices for material and equipment shall include transporting and delivery to any place designated on the City's purchase order, within the corporate limits of the City. In the event of a discrepancy between unit proposal prices and extension thereof, the unit proposal price shall govern.

- B. Names of Bidders: Each proposal shall give the full business address of the Bidder(s) and be signed by them with their usual signature. Proposals by partnerships shall furnish the full names of all partners and shall be signed with the partnership name by one of the members of the partnership or by an authorized representative, followed by the signature and title of the person signing.

Proposals by corporations must be signed with the legal name of the corporation, followed by the name of the state of incorporation and by the signature and title of the President, Secretary or other person authorized to bind it in the matter.

The name of each person signing shall also be typed or printed below the signature. A proposal by a person

who affixes to their signature the word "President," "Secretary," "Agent" or other title without disclosing their principal may be held to be the proposal of the individual signing.

When requested by the City, satisfactory evidence of the authority of the officer or agent signing on behalf of a corporation or partnership shall be furnished.

- C. Delivery: The proposal shall be sealed in an envelope, addressed to:

City of Mentor  
c/o Purchasing Department  
8500 Civic Center Boulevard  
Mentor, Ohio 44060

and delivered to the office of the Purchasing Coordinator on the date set forth in the legal advertisement. The sealed envelope shall also bear the name of the Bidder, the general item(s) proposed, and the date the proposals are to be opened. Proposals will be received until the date and time specified in the legal advertisement. Proposals will be opened and read immediately thereafter, in 2nd Floor Conference Room, Mentor Municipal Center. Proposals received after the date and time specified will be returned unopened to the Bidder.

- D. Proposal to Include All Work: Each proposal shall include all equipment, material, supplies or services described in the Instructions to Bidders, Specifications, Proposal-Contract Form and all drawings.
- E. Withdrawal of Proposal: Permission will not be given to withdraw or modify any proposal after it has been deposited as provided above. Negligence on the part of a Bidder in preparing the proposal confers no right for the withdrawal of the proposal after it has been opened.
- F. Acceptance or Rejection of Proposal: The City reserves the right to accept any proposals within sixty (60) calendar days after the same are opened, as provided above. The City reserves the right to accept any proposals which, in its opinion, are deemed to be in the best interest of the City. The City reserves the right to reject any or all proposals.

In determining the award, each item may be considered separately, and separate contracts may be awarded on the various items, unless specified to the contrary in the Specifications.

- G. Proposal Bond or Check: Each proposal must be accompanied by a cashier's or certified check, an irrevocable letter of credit, or by a proposal bond, signed by a surety company authorized to do business in the State of Ohio, in the amount of ten (10) percent of the pro-

posal and made payable to the City of Mentor, as a guarantee that the contract will be honored in the event it is awarded to the Bidder, and as a guarantee that the Bidder to whom the contract is awarded will sign all documents necessary to formalize the contract, if any.

H. Forfeiture of Check or Proposal Bond: If the Bidder to whom the contract is awarded shall fail to honor the contract, or fail to sign the documents necessary to formalize the contract, if any, the deposit accompanying the proposal shall thereupon be forfeited to the City for and as liquidated damages. The work may then be readvertised or awarded to the deemed second best Bidder as the City may determine.

I. Quantities: The quantities of the work shown on the Specifications and Proposal-Contract Form are estimated by the City and will be used as the basis for comparison of the proposals only. The City reserves the right to decrease or increase any quantities and to eliminate any item(s) on the plans or proposal.

J. Informal Proposals: Proposals may be rejected for the following reasons:

- 1) If the proposal is on a form other than that furnished by the City or if the form is altered or any part thereof detached.
- 2) If there are any unauthorized additions, conditional or alternate proposals, or other irregularities of any kind which may tend to make the proposal incomplete, indefinite or ambiguous as to its meaning.
- 3) If the Bidder adds any provisions reserving the right to accept or reject an award, or to enter into a contract pursuant to an award. This does not exclude a proposal limiting the maximum gross amount of awards acceptable to any one Bidder at any one proposal letting, provided that the City will make any selection of awards.
- 4) If the proposal does not contain a unit price for each pay item listed, except in the case of authorized alternate pay items or lump sum items.

4. A. Competency of Bidders: No proposal will be considered unless the Bidder submitting the same shall furnish evidence satisfactory to the City Manager that they have the necessary equipment, ability and financial resources to fulfill the conditions of the contract and Specifications. Previous experience and responsibility of the Bidders will be considered in awarding the contract. No contract will be awarded to any Bidder who is in arrears to the City upon debt or contract, or who is in default as surety or otherwise upon any obligation to the City.

B. Disqualification of Bidders: Any of the following reasons may be considered as being sufficient for the disqualification of a Bidder and the rejection of their proposal or proposals.

- 1) More than one proposal for the same work from an individual, firm or corporation under the same or different names.
- 2) Evidence of collusion among Bidders. Participants in such collusion will receive no recognition as Bidders for any further work of the City until any such participant shall have been reinstated as a qualified Bidder.
- 3) Proposal prices that obviously are unbalanced.

5. WRITTEN AND ORAL EXPLANATIONS: Should a Bidder find discrepancies in, or omissions from, the drawings or Specifications, or should they be in doubt as to their meaning, they shall at once notify the City, which may send written instructions to all Bidders. The City will not be responsible for any oral instructions.

6. ADDENDUM OR MODIFICATION: Any addendum or modification issued during the time of bidding shall be covered in the proposal and in awarding a contract, such addendum or modification will become part thereof. In the event any such addendum or modification is issued by the City within 72 hours of the time set for the closing of proposals, excluding Saturdays, Sundays and legal holidays, the time for submitting proposals shall be extended one (1) week, with no further advertising of proposals.

7. TAX EXEMPTIONS: The City is exempt from federal excise and transportation taxes and Ohio State sales tax. Prices quoted should not include either federal excise or Ohio State sales tax. Tax exemption certificates covering these taxes will be furnished upon request.

The transportation tax is not applicable on any purchase consigned to the City and no tax exemption certificate is required. If for any reason a contemplated purchase would not be tax exempt, this fact will be indicated in the Specifications, and such taxes may be included in the price or shown as a separate item in the proposal.

8. DISCRIMINATION: In hiring of employees for the performance of work under this contract or any subcontract, neither the Contractor, subcontractor, nor any person acting in their behalf shall by reason of race, creed, color, age, sex or handicap discriminate against any citizen of the State in the employment of any laborer or worker who is qualified and available to perform the work to which the employment relates.

Neither the Contractor, subcontractor, nor any person in their behalf shall in any manner discriminate against or intimidate any employee hired for the performance of work under this contract on account of race, creed, color, age, sex or handicap.

9. INSURANCE: If the Specifications indicate insurance is required, then the Contractor shall obtain and pay for the following types of insurance:

- (a) Commercial General Liability insurance with minimum limits of not less than \$1,000,000 combined single limit. Coverage is to include contractual liability, a per

project general aggregate limit, primary and non-contributory other insurance provision, waiver of subrogation in favor of the City and additional insured status for the City including ongoing operations and products and completed operations. If such coverage is written on a Claims Made or Claims Made and Reported basis, (i) such coverage will have a retroactive date that is equal to or that precedes the date of the contract and be maintained for a minimum period of not less than three (3) years after the termination or expiration of the contract, (ii) may be replaced with other Claims Made or Claims Made and Reported coverage with a retroactive date that is equal to or that precedes the date of the contract and maintained for a minimum period of not less than three (3) years after the termination or expiration of the contract or (iii) may be cancelled after the termination of or expiration of the contract only if it is replaced by an extended reporting period with a duration of not less than three (3) years.

- (b) Automobile Liability insurance providing coverage for all owned, non-owned and hired automobiles with minimum limits not less than \$1,000,000 combined single limit. Coverage shall include additional insured status for the City and a waiver of subrogation for the City.
- (c) Worker's Compensation which meets all statutory minimum requirements

All policies must be written with insurance companies acceptable to the City. All policies are to provide the City with thirty (30) days advanced written notice of cancellation or non-renewal with the exception of cancellation for non-payment of premium which shall be ten (10) days. Contractor shall supply certificates of insurance evidencing the required coverage and shall furnish renewal certificates thirty (30) days prior to the renewal date. Failure of the City to request certificates does not relieve the Contractor from the obligation to maintain the required insurance.

- 10. LIABILITY: The Bidder shall defend, indemnify, and save harmless the City and its officers and agents from all claims, demands, payments, suits, actions, recoveries and judgments of every description, whether or not well founded by law, brought or recovered against it, by reason of any act or omission of said Bidder(s), their agents, subcontractors or employees, in the execution of the contract, or for the use of any patented inventions by said Bidder. A sum sufficient to cover aforesaid claims, including attorneys' fees, may be retained by the City from monies due or to become due to the Bidder under contract, until such claims shall have been discharged.
- 11. ROYALTIES AND/OR LICENSE FEES: The Bidder shall pay all royalties and license fees. The Bidder herein agrees to assume and save the City, its officers and agents harmless from liability of any kind or nature whatsoever, arising out of the use by the City, its officers and agents of any item, appliance, apparatus or mechanism, material or service which may be furnished or installed by the Bidder under the terms of this contract, including patent or copyright infringement, and to defend the City from any and all such liabilities whether or not such claims are well founded by law.

- 12. ASSIGNMENT OF CONTRACT: The Bidder who is awarded a contract shall not assign, transfer, convey, sublet or otherwise dispose of said contract, or right, title or interest in or to the same, or any part thereof, without previous consent in writing from the City Manager, endorsed on or attached to the contract.
- 13. CANCELLATION: Should the material(s) supplied or delivered to the City under this contract fail at any time to meet the Specifications required by the contract, then in such event, the City may cancel this contract upon written notice to the Bidder.
- 14. CONTROL OF WORK: The City Manager, or his designated agent, will decide all questions which may arise as to the quality and acceptability of materials furnished and work performed and as to the rate of progress of the work; all questions which may arise as to the interpretation of the plans and Specifications; all questions as to the acceptable fulfillment of the contract on the part of the Contractor, and as to compensation.
- 15. CLAIMS FOR ADJUSTMENT AND DISPUTES: If, in any case, the Contractor deems that additional compensation is due for work or material not clearly covered in the contract or not ordered by the City Manager as extra work, as defined herein, the Contractor shall notify the City Manager in writing of their intention to make claim for such additional compensation before they begin the work on which the claim is based. If such notification is not given and the City Manager is not afforded proper facilities by the Contractor for keeping strict account of actual costs as required, then the Contractor hereby agrees to waive any claim for such additional compensation. Such notice by the Contractor, and the fact that the City Manager has kept account of the cost aforesaid, shall not in any way be construed as proving or substantiating the validity of the claim. If the claim, after consideration by the City Manager, is found to be just, it will be paid as extra work in the amount as approved by the City Manager.
- 16. DURATION OF CONTRACT: The duration of the contract shall be for the period stated in the Specifications, and shall include all material, equipment and/or services ordered or delivered during the period. All prices quoted shall be for a definite fixed period unless otherwise noted in the Specifications.
- 17. PURCHASES: After a contract has been signed, it shall only become operative upon delivery to the Bidder a duly signed purchase order. The City shall only be obligated under the contract to the extent of such purchase order. The City shall not become liable for any claims in the event that the total quantity of material ordered or services performed under the contract should prove to be greater or less than the estimated amount in the Specifications.
- 18. DELIVERY: The Bidder agrees to make deliveries of supplies and materials within a reasonable period from the time purchase orders are received, which reasonable time is estimated to be thirty (30) days.

If deliveries are not made within such period, then the City may purchase such items in the open market; and if the prices paid by the City shall be greater than the contract price, the Bidder agrees to reimburse the City for any loss or losses that the City may thereby sustain.

United States, State of Ohio and City of Mentor which are applicable during the performance of the work.

QUESTIONS: Call the Finance Department at (440) 974-5776.

Delivery time for vehicles and equipment may be extended beyond thirty (30) days, provided the Bidder has noted the delivery time in the appropriate space on the Proposal-Contract Form.

19. PAYMENT OF INVOICES: Invoices will be due and payable within thirty (30) days of receipt of the invoice by the City. All invoices should be mailed to the attention of the Accounts Payable Department. Payments may be made on a basis of estimated partial completion of work or delivery, and the City may withhold a percentage of each partial payment until completion of the contract. The City may withhold a percentage of the final estimate for a specified period as a guarantee. Such a procedure for partial payments must be provided for in the Specifications.
20. CONTRACT BOND: The successful Bidder will be required to furnish the approved bond for the faithful performance of the contract in the amount of one hundred percent (100%) of the contract price. Such bond shall be that of an approved surety company or personal bond upon which the sureties are persons not interested in the contract, or, if interested, collateral security shall be furnished, all of which is to be to the satisfaction of the Law Director, including sureties.  
  
In lieu of a performance bond the City may elect to hold the Proposal Deposit Check, submitted with the proposal, until the contract has been fulfilled. **Any deviation from the required one hundred percent (100%) figure will be noted in the Specifications.**
21. GENERAL: Contractors shall furnish all labor, equipment, materials, services and supplies necessary to complete the proposed work. All work shall be performed according to all standards of good workmanship complete in every detail. Contractors shall coordinate their work with the work of others and, upon completion, remove tools, equipment, waste and debris and leave the site in "broom-clean" condition. Contractors shall warrant all equipment, materials, services and supplies with the normal and usual warranties, including, where applicable, warranties of merchantability and fitness for a particular purpose.
22. WAIVERABILITY: The City of Mentor reserves the right to accept any part of any proposal and reject all or parts of any and all proposals, and waive any informalities in the bidding procedure.
23. PREVAILING WAGE: Contractors must comply with ORC Chapter 4115 when applicable. It is the Contractor's responsibility to contact the City's Prevailing Wage Coordinator to determine requirements.
24. TAXES: Contractor shall pay and/or withhold all sales, consumer, use, employment and other taxes (including the City of Mentor 2% income tax) paid or withheld by Contractor in accordance with the Laws and Regulations of the



**III. FORM OF NONCOLLUSION AFFIDAVIT**

STATE OF \_\_\_\_\_ )

COUNTY OF \_\_\_\_\_ )

\_\_\_\_\_, being first duly sworn, deposes and says  
(Individual Name)

That he/she is \_\_\_\_\_ of \_\_\_\_\_  
(Sole Owner, Partner, President, Secretary, etc.) (Corporation Name)

the party making the proposal or bid; that such bid is genuine and not collusive or sham; that said Bidder has not colluded, conspired, connived, or agreed, directly or indirectly with any Bidder or person, to put in a sham bid, or that such other person shall refrain from bidding, and has not in any manner, directly or indirectly sought by agreement or collusion or communication or conference, with any person, to fix the bid price of affiant or any other Bidder, or to fix any overhead, profit, or cost element of said Bid price, or of that of any other Bidder, or to secure any advantage against the Owner, or any person interested in the proposed Contract; and that all statements contained in said proposal or bid are true; and further, that such Bidder has not, directly or indirectly submitted this Bid, or the contents thereof, or divulged information or data relative thereto to any association or to any member or agent thereof.

\_\_\_\_\_  
Affiant

Subscribed and sworn to before me this \_\_\_\_ day of \_\_\_\_\_, 2023.

\_\_\_\_\_  
Notary Public

My Commission Expires: \_\_\_\_\_

#### IV. BUSINESS ENTITY RESOLUTION

\_\_\_\_\_, of \_\_\_\_\_  
(Name of Officer) (Name of Business Entity)

an \_\_\_\_\_ Business Entity hereby certifies that the following is a true  
(State where incorporated/organized if applicable)

and correct copy of a resolution duly adopted by the Board of Directors of \_\_\_\_\_,  
(Business Entity Name)

on \_\_\_\_\_, \_\_\_\_\_, to wit:  
(Month, Day) (Year)

“Resolved, that \_\_\_\_\_\* of this Business Entity, namely  
(Name of Officer)

\_\_\_\_\_, be and he/she hereby is authorized and directed to enter into any and all  
(Title of Officer)

contracts, bid guaranty and performance bonds with **THE CITY OF MENTOR, OHIO**, for the purpose of

furnishing labor and/or materials as to \_\_\_\_\_  
(Title of Bid)

at such price and upon such terms and conditions, including any amendments or modifications thereto, as

said \_\_\_\_\_ in his/her sole discretion shall deem best,  
(Title of Officer)

and that said actions shall be binding upon the Business Entity.

“Resolved, further, that said \_\_\_\_\_\* be, and he/she further is  
(Name of Officer)

hereby authorized and directed to execute and deliver unto said **CITY OF MENTOR, OHIO** other  
instruments which in his/her discretion he/she shall deem necessary to carry out the forgoing resolution.”

IN WITNESS WHEREOF, I have hereunto set my hand and affixed the seal of said Business  
Entity (if applicable) at \_\_\_\_\_ this \_\_\_\_\_ day of \_\_\_\_\_,  
and I further certify that said resolution is still in force and effect.

\_\_\_\_\_  
**SECRETARY**

**SEAL**

BER-1

\*Name must agree with signature on page Bidders Acceptance to Contract

## V. BID SUBJECT TO ACCEPTANCE AS CONTRACT

A. BIDDER NAME (PRINT/TYPE): \_\_\_\_\_

BIDDER ADDRESS: \_\_\_\_\_

\_\_\_\_\_

BIDDER PHONE/EMAIL: \_\_\_\_\_

STATE WHERE ORGANIZED,  
INCORPORATED, OR WHERE  
DOING BUSINESS AS:

\_\_\_\_\_ DATE: \_\_\_\_\_

### BID

Per *Proposal-Contract Form*, the undersigned having been authorized to enter into Bids/Contracts on behalf of the business entity, hereby on behalf of the business entity agrees to perform the services and/or deliver the goods pursuant to the terms and conditions of the component parts described below, all of which, if the above business entity is awarded the bid, shall be the terms and conditions of the contract.

\_\_\_\_\_  
Name (PRINT/TYPE)

\_\_\_\_\_  
Title

\_\_\_\_\_  
Date

\_\_\_\_\_  
Signature

**B. NOTICE OF AWARD**

Whereas, \_\_\_\_\_ responded to an invitation to bid as to the Supply, Delivery, and Start-up of a Golf Course Irrigation Pump Station for Black Brook Golf Course and whereas said bid by \_\_\_\_\_ was approved by the City Council as the lowest and best bid, now, therefore, the City of Mentor awards the contract subject to final acceptance below to \_\_\_\_\_ to be performed pursuant to the terms and conditions specified in the following documents (component parts):

1. Instructions to Bidders
2. Bond or Certified Check
3. Specifications: General Requirements/Contractor’s Responsibilities
4. Proposal/Contract Form
5. Other

\_\_\_\_\_  
Veronica Fetsko, *Purchasing*

\_\_\_\_\_  
*Date*

**C. VENDOR AGREEMENT**

\_\_\_\_\_ hereby agrees to perform the services as bid and agrees to abide by all terms and conditions as identified. In the event of contradiction or ambiguity between the paragraphs contained in the *Instructions to Bidders* versus the other more specific paragraphs under *Specifications: General Requirements/ Contractor’s Responsibilities, Proposal/Contract Form, Other*, the paragraphs in the *Specifications: General Requirements/Contractor’s Responsibilities, Proposal/Contract Form and Other*, shall control. And whereas, the City of Mentor intends to be bound by the contract, it will pay to \_\_\_\_\_ the sums so stated in the *Proposal/Contract Form* upon satisfactory delivery of the goods and/or performance of the service.

\_\_\_\_\_ has reviewed the above component parts of the contract documents and finds no ambiguity in the terms and conditions thereof.

\_\_\_\_\_  
Company Officer

\_\_\_\_\_  
*Date*

**D. ACCEPTANCE BY THE CITY OF MENTOR**

THE FOREGOING CONTRACT IS HEREBY ACCEPTED AS TO ALL OF THE COMPONENT PARTS AND, IN SPECIFIC, TO ITEM(S) #

Item(s) #

Pursuant to Ordinance \_\_\_\_\_ Passed on \_\_\_\_\_.

By the Council of the City of Mentor, for the period through \_\_\_\_\_.

**FUNDS AVAILABLE:**

\_\_\_\_\_  
David W. Malinowski, *Finance Director*

\_\_\_\_\_  
*Date*

\_\_\_\_\_  
Kenneth J. Filipiak, *City Manager*

\_\_\_\_\_  
*Date*

**APPROVED AS TO FORM:**

\_\_\_\_\_  
Joseph P. Szeman, *Law Director*

\_\_\_\_\_  
*Date*

**E. ESCROW WAIVER**

In accordance with a certain Contract between the City of Mentor, (hereinafter referred to as "the Owner") and \_\_\_\_\_, (hereinafter referred to as "the Contractor"), it is mutually agreed by and between the parties hereto that because of the short term duration of the within contract, no escrow account will be established pursuant to Sections 153.13, 153.14 and 153.63 of the Ohio Revised Code nor shall any interest be paid on any retainage.

CITY OF MENTOR

\_\_\_\_\_  
Kenneth J. Filipiak, City Manager

COMPANY

\_\_\_\_\_

SAMPLE

**F. DELINQUENT PERSONAL PROPERTY STATEMENT**

\_\_\_\_\_ having been awarded a contract by the City of Mentor, hereby affirms under oath, pursuant to Ohio Revised Code Section 5719.042, that at the time the bid was submitted, my company **was / was not** charged with delinquent personal property taxes on the General Tax List of Personal Property for Lake County, Ohio.

If such charge for delinquent personal property tax exists on the General Tax List of Personal Property for Lake County, Ohio, the amount of such due and unpaid delinquent taxes, including due and unpaid penalties and interest, shall be set forth below.

This statement shall be incorporated into the Contract made between the City of Mentor and \_\_\_\_\_ and no payment shall be made with respect to any Contract unless such statement has been so incorporated as a part hereof.

Delinquent Personal Property Tax \$ \_\_\_\_\_

Penalties \$ \_\_\_\_\_

Interest \$ \_\_\_\_\_

Signed: \_\_\_\_\_

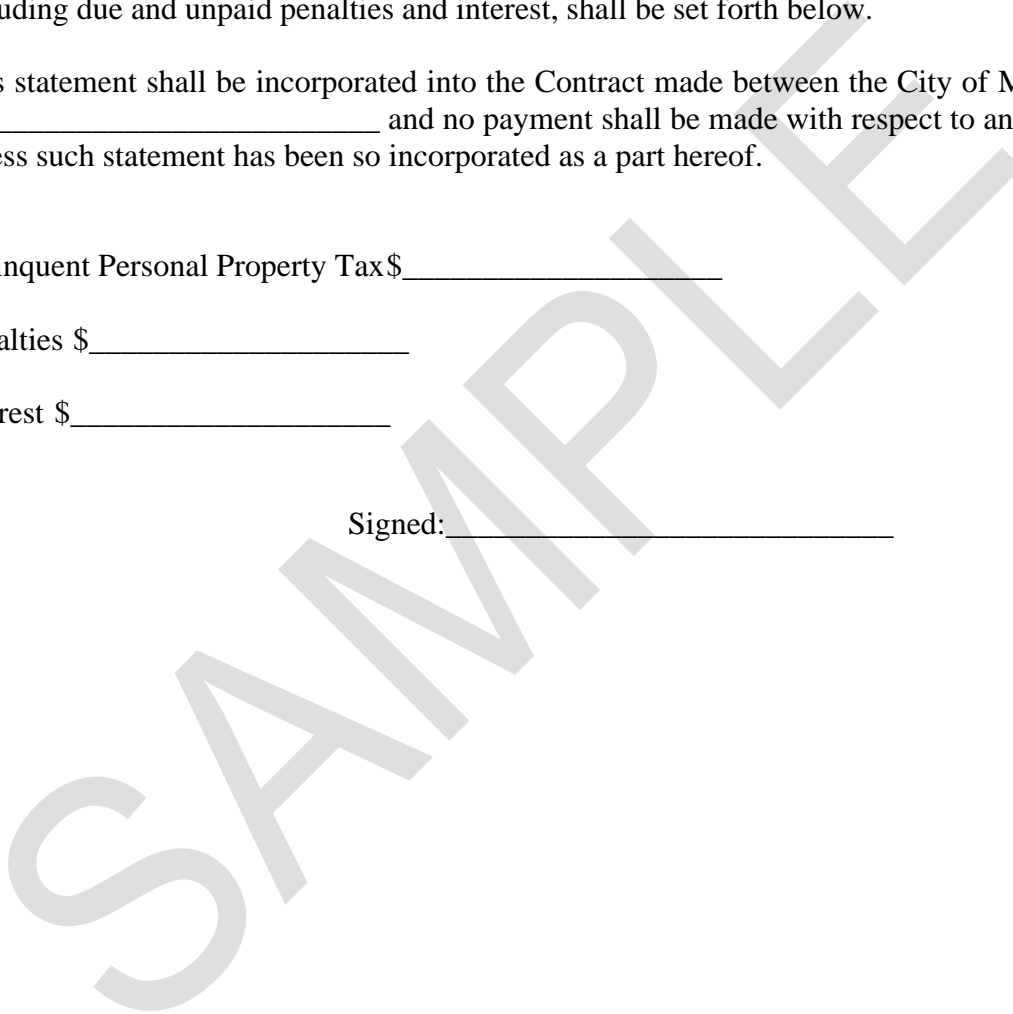

**AFFIDAVIT**  
OF COMPLIANCE WITH OHIO REVISED CODE SECTION 3517.13

STATE OF OHIO

COUNTY OF LAKE

\_\_\_\_\_ being duly sworn deposes and states as follows:

1. I am duly authorized to make the statements contained herein on behalf of \_\_\_\_\_ (“the Contracting Party”).
2. The Contracting Party is a/an (select one):
  - Individual, partnership, or other unincorporated business association (including without limitation, a professional association organized under Ohio Revised Code Chapter 1787), estate, or trust;
  - Corporation organized and existing under the laws of the State of \_\_\_\_\_.
  - Labor organization.
3. I hereby affirm that the Contracting Party and each of the individuals specified in R.C. 3517.13(I) (with respect to non-corporate entities and labor organizations) or R.C. 3517.13(J) (with respect to corporations) are in full compliance with the political contribution limitations set forth in R.C. 3517.13(I) and (J), as applicable.
4. I understand that a false representation on this certification will incur penalties pursuant to 3517.992 (R)(3).

Affiant further sayeth naught.

By: \_\_\_\_\_

Title: \_\_\_\_\_

SWORN TO BEFORE ME and subscribed in my presence this \_\_\_\_\_ day of \_\_\_\_\_, 2023.

\_\_\_\_\_  
Notary Public

My commission expires: \_\_\_\_\_



## **VI. SUPPLY, DELIVER AND START-UP OF A GOLF COURSE IRRIGATION PUMP STATION AT BLACK BROOK GOLF COURSE**

### **GENERAL REQUIREMENTS**

Intent: The intent of these specifications is to describe the purchase, delivery and start-up of a Golf Course Irrigation Pump Station for use by the City of Mentor Black Brook Golf Course employees.

Brand or Trade Name: Brand names, where mentioned in these specifications, are not intended to be restrictive, but rather to indicate the level of quality required by the City. In any instance where a brand name is mentioned, it is assumed that the phrase “or equal” shall follow.

Warranty: Please list on Proposal-Contract form period of warranty. Bidder shall submit written conditions with the bid proposal.

O.S.H.A.: Bidder shall comply with the provisions of the Occupational Safety and Health Act and Standards and Regulations issued there under and certify that all items conform to and comply with said standards and regulations.

Proposal (Bid) Bond: In accordance with Section 3G of the Instructions to Bidders. A certified check or bond in the amount of 10% of the proposal and payable to the City of Mentor must accompany the proposal or a “Bid Guarantee and Contract Bond” (AKA “rollover bond”) per O.R.C. sections 153.54 and 153.571.

Contract (Performance) Bond: Section 20 of the Instructions to Bidders. The successful bidder will be required to furnish an approved Contract bond for the faithful performance of the contract in the amount of one hundred percent (100%) of the contract price per O.R.C. 153.54 and 153.57.

The bond shall be underwritten by a Surety Company authorized to transact business in the State of Ohio having an Ohio agent and listed on the most current Department of Treasury, Circular 570, “Surety Companies Acceptable on Federal Bonds”.

Registration: All Contractors shall be registered to work in the City of Mentor. Registration information can be found at Mentor Gateway. Registration shall include completing required forms, providing a certificate of liability insurance, and a One Hundred Dollar (\$100.00) registration fee.

Permit: The City of Mentor Building Department will issue a Certificate of Plan Approval (permit) for this work. The permit fees, inspection fees, and deposit will be waived. Inspections during the course of the work will be required.

Contact: Any questions regarding the specifications please direct to Brian E. Vinchesi, Irrigation Consulting, Inc., [bvinchesi@irrigationconsulting.com](mailto:bvinchesi@irrigationconsulting.com) or City of Mentor Greens Superintendent, Nick Fortunato, [Fortunato@cityofmentor.com](mailto:Fortunato@cityofmentor.com).

The City reserves the right to accept or reject any or all bids or award or reject any combination of bid items.

## MINIMUM REQUIREMENTS

These specifications detail minimum requirements acceptable to the City of Mentor. Should the manufacturer's current specifications exceed these, they shall be considered minimum and shall be furnished, and equipment and components included in the bid shall be stipulated.

**Any additions, deletions or variations from the minimum must be stated with the specifications. Bidder shall stipulate components supplied in providing a complete unit.**

Any and all parts not specifically mentioned in these specifications but which are required for proper and safe operation shall be furnished by the bidder and shall conform in strength, quality of material and workmanship to that provided by the industry in general. All items not specifically mentioned but which are standard factory items shall be furnished.

## SPECIFICATIONS

1. Manufacturer shall at once, following examination of the documents, notify the City of Mentor of any errors, ambiguities or inconsistencies discovered.
2. Any clarification to the documents needed by the Manufacturer shall make a written request to Finance Department, City of Mentor by the date indicated in the project schedule.
3. Changes, interpretations and corrections to the Bidding Documents will be made by Addendum. Any changes to the bidding documents made otherwise shall not be binding and Manufacturer shall not rely upon them.
4. References: Irrigation Manufacturer must supply a minimum of five (5) references for pump station work of this type with their Bid including names and phone numbers of the Golf Course Manager and Superintendent and the type equipment installed on the form provided.
5. Manufacturer shall have suitable financial status to meet obligations for this project.
6. The objective of these specifications is to supply, deliver and start-up a new golf course irrigation pump station. Manufacturer will be responsible for the work indicated including:
  - a. Manufacturing pump station
  - b. Delivering pump station
  - c. Pump station start-up
  - d. Pump station winterization
7. City of Mentor will be responsible for:
  - a. Wet well and concrete pad installation
  - b. Pump station installation
  - c. High voltage power supply connections

8. Work specified herein shall comply in accordance with all governing ordinances, laws and regulations that apply to the project. If the Manufacturer performs any work contrary to such codes, laws or regulations, they shall assume full responsibility and bear all costs necessary to correct the work, at no additional cost to the City of Mentor.
9. Bidders must study the specifications and shall be responsible for discovering and reporting to the City of Mentor any error, omission, inconsistency or other defect that should be apparent to a reasonable prudent Manufacturer. The City of Mentor will interpret, correct or otherwise clarify the Project Documents as necessary, and will make any interpretation, correction or clarification in writing and issue it an addendum to all Bidders.
10. Any work undertaken by the Manufacturer containing possible errors or conflict without or before a written interpretation or instruction by the City of Mentor is done at the Bidders' own risk.
11. Pump station shall be delivered in a covered and contained truck to protect it from weather. Failure to deliver pump station in a protected environment shall result in rejection of the pump station by the Owner's Representative.
12. Manufacturers, employees and visitors to the site are expected to maintain an appropriate appearance while working on the site. Shirts must be worn. Owner's Representative shall strictly enforce this provision.
13. Parking is not allowed near the Clubhouse, in handicapped or fire access lanes, or any private ways in or surrounding the property. Vehicles so parked may be towed at the expense of the Manufacturer. Coordinate parking and staging requirements with the Owner's Representative and Golf Course Superintendent.
14. Owner's Representatives will punch list the pump station when the Manufacturer reports it is operational. Owner's Representatives will advise the Manufacturer whether or not such work has been completed in accordance with the Contract Documents. When the Manufacturer's work and submittals have been fully completed in accordance with the Contract Documents, the City of Mentor and the Owner's Representatives will authorize final payment.
15. Final acceptance of the work will be considered when the pump station is operating to the satisfaction of the City of Mentor. The pump station will be accepted as a whole and not in parts. Final payment will be provided when the Manufacturer has demonstrated to the City of Mentor that the Manufacturer has delivered and had approved Maintenance and Operating Manuals as specified.
16. Delivery: Please indicate on Proposal-Contract form delivery date. The successful bidder will be required to deliver the equipment within the number of days stated.
17. Bidder will need to provide written documentation that any deviations from the specifications or alternate offered is comparable to our requirements.

VFD TURBINE PUMP STATION REFERENCES: (Must be a s close to Mentor, Ohio as possible)

**1. Project Name:** \_\_\_\_\_

Address: \_\_\_\_\_

City, State, Zip: \_\_\_\_\_

Phone: \_\_\_\_\_

Year/Type of Installation: \_\_\_\_\_

**2. Project Name:** \_\_\_\_\_

Address: \_\_\_\_\_

City, State, Zip: \_\_\_\_\_

Phone: \_\_\_\_\_

Year/Type of Installation: \_\_\_\_\_

**3. Project Name:** \_\_\_\_\_

Address: \_\_\_\_\_

City, State, Zip: \_\_\_\_\_

Phone: \_\_\_\_\_

Year/Type of Installation: \_\_\_\_\_

**4. Project Name:** \_\_\_\_\_

Address: \_\_\_\_\_

City, State, Zip: \_\_\_\_\_

Phone: \_\_\_\_\_

Year/Type of Installation: \_\_\_\_\_

**5. Project Name:** \_\_\_\_\_

Address: \_\_\_\_\_

City, State, Zip: \_\_\_\_\_

Phone: \_\_\_\_\_

Year/Type of Installation: \_\_\_\_\_

## PUMP STATION AND ENCLOSURE

### PART I -- GENERAL

#### QUALITY ASSURANCE

Pump station Manufacturer shall furnish proof of having at least five (5) years' experience in the manufacture, start-up and adjustment of flow-based microprocessor controlled variable speed pump stations of this size and scope.

City of Mentor will not consider pump station bids from Manufacturers who have not successfully manufactured at least five stations comparable to what is specified herein within the past three years, and who cannot be recommended by their references.

Control system, drive equipment and other electrical equipment and the manner in which they are installed shall conform to the latest edition of the National Electric Code.

#### 1.02 WORK INCLUDED

- A. Provide, deliver and test a totally automatic, prefabricated, multiple pump, variable speed, vertical turbine pump station and enclosure as outlined in these specifications.
- B. Main electrical connection shall be by others. This work shall consist of installation of a single conduit from the supply point at the transformer/meter to the pump station, bumping of pump motors for proper rotation, etc. Local permitting and inspection/approval will be the responsibility of others.
- C. Pump station wiring, including motor connections, pressure transducers, level controls and flow sensors shall be by the Manufacturer.
- D. Omission of material from this specification is not to be interpreted to the effect that omitted material will not be furnished by the Manufacturer. Material and labor, unless specifically indicated as being furnished by others, must be furnished and installed by the Manufacturer under the signed agreement.

#### 1.03 QUALITY ASSURANCE

- A. Award of a Contract for the work shall be contingent upon approval of the pump station Manufacturer by the City of Mentor and the Owner's Representative after review of their qualifications.

Pump station Manufacturer shall furnish proof of having at least five (5) years' experience in the manufacture, start-up and adjustment of flow based microprocessor controlled variable speed pump stations of this size and scope. A list of five (5) past projects within the last 3 years comparable to that specified herein, including names and phone numbers of owners/operators of comparable stations shall be submitted.

References must be for similar stations as close as possible to Black Brook Golf Course.

- C. Applicable requirements of accepted Standards and Codes shall apply to the work of this Section:
1. American Society of Testing & Materials (ASTM)
  2. National Electric Code (NEC)
  3. Institute of Electronic and Electrical Engineers (IEEE)
  4. Underwriters Laboratory (UL)
  5. Occupational Health and Safety Administration (OSHA)
- D. Control system, drive equipment and other electrical equipment and the manner in which they are installed shall conform to the latest National Electric Code.

#### 1.04 TESTS

- A. Manufacturer shall perform tests on the pump station in the presence of the Owner's Representative.
- B. See applicable paragraphs under Part III, EXECUTION, this Section.

#### 1.05 SUBMITTALS

- A. Product Data: The successful Manufacturer shall submit an electronic copy of the following Manufacturer's catalog cut/equipment data for approval before manufacturing is begun. Submittals shall be marked-up to indicate features/capacities/sizes/etc. as they apply to this project:
1. Turbine Pumps
  2. Submersible Pump
  3. Variable Speed Drives
  4. Control Panel
  5. Touch Screen
  6. Flow sensor
  7. Check Valves
  8. Isolation Valves
  9. Pipe and Fittings
  10. Programmable Logic Controller
  11. Pressure Release Valve
  12. Wye Strainer
  13. Motors
  14. Pressure Transducers
  15. Relays
  16. Level Transducers
  17. Float
  18. Doglegs

- 19. Monitoring Software
- 20. Enclosure
- 21. Miscellaneous Materials

B. A complete pump station submittal including wiring circuitry with terminals, components and wiring identified shall be provided for approval before manufacturing is begun.

#### 1.06 DELIVERY, HANDLING AND STORAGE

- A. Pack, ship, deliver and test pump station in such a manner as to protect it from damage due to weather, vandalism, theft, shipping or other cause.
- B. Pump station and its components shall be shrink wrapped or tarped during shipping regardless of trailer type (enclosed or flatbed). Imperfections in the station due to failure to protect the station and its components during shipping shall be repaired to the satisfaction of the Owner's Representative at no additional cost to the City of Mentor.
- C. Manufacturer shall be responsible for coordination of delivery of the pump station on a schedule determined with the Owner's Representative and installing Contractor. Manufacturer will be responsible for technical start up.

#### 1.07 WARRANTIES

- A. Pump station Manufacturer shall warrant materials and equipment to be free of defects for a period of two (2) years from the date of final acceptance.
- B. Pump station Manufacturer shall be responsible for coordinating warranty on items, whether or not of their manufacture. Warranty shall be one contact, which is the Manufacturer's authorized service center.
- C. In addition, where equipment Manufacturer's offer extended warranties, pump station Manufacturer shall honor the material guarantee to the full extent of the Manufacturer's Warranty Statement.
- D. Manufacturer shall perform the first year (assumed 2025) spring start up and fall winterization (assumed 2024) following acceptance of the pump station to maintain the warranties.

#### 1.08 MAINTENANCE AND OPERATING INSTRUCTIONS

- A. Bid shall include an allowance for eight (8) hours of instruction (two separate visits) of Black Brook Golf Course's personnel at completion of Check/Test/Start-up/Adjust operations. Owner's Representative shall set dates of final test and training. Pump station testing and instruction shall be provided by the Manufacturer's factory authorized and published service center and not by the installer or distributor.

- B. Materials dealing with the pump station including bid documents, submittals, and Operating and Maintenance material shall be specific to the Black Brook Irrigation pump station. Generic statements or non-applicable information will not be accepted and may affect the award of the bid and final acceptance of the station by the City of Mentor.
- C. Upon application for acceptance and final payment Manufacturer shall provide a customized electronic manual labeled as MAINTENANCE AND OPERATING INSTRUCTIONS FOR BLACK BROOK GOLF COURSE'S IRRIGATION PUMP STATION, to the Owner's Representative's office. After review and acceptance, the files will be forwarded to the City of Mentor/Black Brook Golf Course. Maintenance & Operating Manuals shall contain:
  - 1. A complete set of original "Approved" submittals of pump station equipment;
  - 2. A complete set of operating instructions for each item of pumping, control, drive and safety equipment.
  - 3. A complete set of maintenance instructions for each item of pumping, control, drive and safety equipment.
  - 4. A copy of the pump station schematics and record drawings.
  - 5. A copy of the suggested flow and pressure settings for the various control equipment for the station.
  - 6. A complete set of pump curves for the pumps installed with the operating points and operating curves highlighted.
- D. Binders shall be divided into sections with table of contents and index dividers.

## PART 2 - PRODUCTS

### 2.01 GENERAL

- A. Materials to be incorporated in the pump station shall be new, without flaws or defects and shall conform to standards set forth in these specifications and as approved by the Owner's Representative.
- B. Pump station and enclosure will be installed on a new 5 foot diameter concrete wet well.
- C. Power supply shall be three phase, 480-volt, 60 hertz, 200 amps and shall be brought to the pump station by others.
- D. Pump station is to be completely, wired, piped, painted, and tested before leaving the factory. The pump manifold and pipe shall be tested at 150% of maximum pump pressure and be leak and drip free. The electrical components shall be tested at the rated voltage and the control circuits shall be tested in simulated conditions.
- E. No pressure gages, pressure switches, water activated devices, or water lines shall be installed inside of an electrical control panel.



- F. Pump station shall be prefabricated in an enclosure and mounted on steel skid to support components and to serve as a mounting base.
- G. Necessary lift points shall be indicated to unload and set the pump station.
- H. The pump station shall be capable of pumping minimum 1,000 gpm @ 115 psi (266 feet) as it exits the station. The pressure maintenance pump shall pump approximately 50 gpm at 1415 psi (266 feet) on as flat a curve as possible. Pumps shall be two (2) approximately 500 gpm, not to exceed 50 horsepower.
- I. An access hatch to the wet well through the station skid shall be built into the pump station skid or a hinged cover welded to the side of the skid.
- J. For bidding purposes, pump station wet well is 14 feet deep.
- K. Pump station shall be as manufactured by MCI Flowtronex, Watertronics or approved equal.

## 2.02 CONSTRUCTION

- A. Nuts, bolts, washers and fasteners shall be stainless-steel, zinc or cadmium plated for corrosion resistance.
- B. Pipe within the pump station shall independently supported. Pumps and other equipment shall not be used to support the pipe.
- C. Pump station construction shall be of the modular form utilizing a steel base with minimum 3/16-inch steel floor plate and minimum 6-inch channel iron base structurally adequate to support the pumps, pipe and electrical equipment and enclosure as a single integral assembly.
- D. Pump station discharge header shall be constructed from Schedule 40 standard weight steel of suitable design flow so that the velocity does not exceed 15 feet per second. The header shall be constructed with 150# cast iron flanged, Victaulic, or welded fittings as required for valved connections to pump discharge header.
- E. Pump station to connect to new irrigation system 10-inch HDPE mainline with flange connected dogleg fitting.
- F. Pressure release/wye strainer is to discharge back into the pond through a 4-inch HDPE pipe with flange connected dogleg fitting.

## 2.03 VERTICAL TURBINE PUMPS

- A. Entire pump assembly including the bowl assembly, column and shafting shall be of a

single United States manufacture. The pump Manufacturer shall have a network of service centers and pump technicians to handle service, repair, and the handling of warranty procedures.

Bowl assemblies including suction case, intermediate bowls and discharge bowls shall be cast iron. Closed impellers shall be of stainless-steel construction and statically balanced. Impellers shall have perihedral seals to provide vertical cylindrical and horizontal surface impeller sealing. This seal shall prevent pump shaft stretch from affecting pump performance. Impellers shall be adjusted vertically by means of an adjusting nut located at the top of the pond.

Pump suction case shall incorporate vanes to guide fluid and have a "flare" to minimize shock and entrance losses.

Pump shafts shall be turned, ground and polished 316 stainless steel with 100,000 psi tensile strength. The pump shafts shall meet the requirements of size, horsepower rating, smoothness and straightness tolerances of AWWA. The shafts are to be supported by bearings above and below each impeller at a minimum of every 5 to 7 feet.

Suction case, intermediate bowl and discharge case bearing shall be composite, high temperature, self-lubrication with internal flutings. The bearings shall stabilize the top and bottom of the pump shaft and provide accurate alignment of impellers at the intermediate bowls. The suction case bearing shall be a minimum of five shaft diameters in length and shall have a stainless-steel collar immediately above to prevent abrasives from entering the bearing.

Pump strainers shall be stainless-steel basket type, corrosive resistant. The open area of the strainer shall not be less than four times the suction bell inlet area.

Discharge column pipes shall conform to ASTM A106 standards. Column ends shall be machine faced to provide a butt fit between column sections to maintain alignment throughout pump column assembly. Discharge column pipe shall be furnished in interchangeable sections with flanged or threaded couplings. Line shafts shall be polished steel utilizing non-corrosive sleeves at each bearing. Line shafts shall have steel couplings with left hand threads. Stainless steel shaft as discussed above shall be used when passing through the stuffing box.

- B. Ductile iron discharge head shall support the entire pump assembly and shall be an open style head. The discharge header shall be constructed with a minimum 60,000 psi tensile strength with a safety factor of 5 to 1 to provide maximum strength. The discharge header shall be flanged with the top diameter matching the diameter of the motor base to evenly distribute the load. Discharge header shall be equipped with a drain for leakage. No leakage is allowed to run onto the skid

or

Steel discharge head shall support the entire pump assembly and shall be an open style head. The discharge header shall be constructed with a minimum 60,000 psi tensile strength steel with a safety factor of 5 to 1 to provide maximum strength. The discharge header shall be flanged with the top diameter matching the diameter of the motor base to evenly distribute the load. Discharge header shall be equipped with a drain for the stuffing box leakage. No leakage is allowed to run onto the skid.

- C. Each turbine pump discharge head shall contain a mechanical seal assembly located where the line shaft protrudes through the discharge head. The mechanical seal assembly shall consist of a main housing, shaft sleeve assembly, locking and drive collars. The shaft sleeve shall be machined from 316 stainless steel. The locking and driving collars shall be machined from 7075 aluminum and anodized after machining. Integral to the seal housing, a permanently lubricated ball bearing shall be mounted, located out of the pumping media. The mechanical seal shall be resistant to corrosion and abrasives, totally self-lubricating, and rated for no less than 150 psi. The seal assembly shall require no bypass tubes or related devices to provide cooling or lubrication.

Integral to each turbine pump discharge head, an air release port shall be located at the highest point of the head. A multi-turn valve shall be located at the release port, adjusted to ensure full expulsion of air upon pump start-up. Air/water discharge from the air release valve shall be piped back to the wet well and also serve to relieve water to prevent the pumps from over-heating during shut-off conditions.

For bidding purposes, turbine pumps shall have a 13-foot set from the bottom of the strainers to the top of the pump pedestal skid support. Manufacturer shall coordinate set with Irrigation Consultant before assembling pump shafts. Minimum pump efficiency shall be 80 percent.

## 2.04 VERTICAL TURBINE MOTORS

- A. Motors shall be of U.S. manufacture, 1800 RPM, 3 Phase, 480 volt rated for 60 cycle, 40-degree C ambient, continuous performance. Pump motors shall be squirrel cage induction type vertical hollow shaft motors with rodent screens, conforming to the latest standards of the current American National Standard Association including rating, characteristics, and tests. The pumps and motors shall be connected by a bolt-down coupling located in the motors. The motors temperature rise shall conform to NEMA MG-1-12.42 for Class F installations. The motors shall have a thrust bearing of significant rating to carry the weight of rotating parts and the hydraulic thrust of the pump. Bearing should be sized for a minimum life of 5 years.

Motors shall be equipped with a non-reverse ratchet to protect the pumps from reverse rotation damage caused by a check valve failure or incorrect electrical phasing.

Motors shall be sized so that the maximum possible load developed under the pumping conditions specified will not exceed the nameplate horsepower. Pumps designed with the motors running in their service factor at design point will be rejected.

Pump station Manufacturer shall provide on each pump motor a 120-volt, single phase space heater of ample size to prevent condensation within the motor. The space heater shall be de-energized when the motor is running.

Minimum motor efficiency shall be 94.5 percent. Horsepower's shall not exceed 50 horsepower.

## 2.05 SUBMERSIBLE PUMP AND MOTOR

- A. Pump station skid shall include a multistage turbine type submersible pressure maintenance pump capable of pumping approximately 50 gpm at 115 psi (266 feet). Minimum pump efficiency shall be 65 percent. Pump shall include 100,000 psi stainless steel shaft, type 416 with water lubricated bronze suction, discharge and intermediate bowl bearings. Impellers shall be enclosed cast-bronze balanced and be constructed from C836 bronze and cast-iron bowls shall meet ASTM-A48, class 30. The bowls shall have vitra glass lined waterways for maximum efficiency and wear protection. The inlet area shall have a net open area of at least four times the eye area of the impeller. Submersible pump shall be as manufactured by Gould's or Grundfos.
- B. Submersible motor shall meet NEMA standards and operate within the nameplate horsepower for the points on the operating curve, maximum of 5 horsepower. The motor shall be of corrosion resistant construction, 316 stainless steel shell, splines stainless steel shaft, cast iron end bells, hermetically sealed windings, Kingsbury-type thrust bearings, pressure equalizing diaphragm, removable water-bloc lead connector and UL recognized.
- C. Manufacturer shall use a properly installed submersible splice kit to connect to the submersible motor. The power cable shall be UL Listed, type TW rated for 600 volts with ground wire.
- D. Bottom of pressure maintenance pump shall be installed minimum 6 inches, and maximum 8 inches, from top of wet well floor.

## 2.06 VARIABLE SPEED DRIVES

- A. Invertor Manufacturer shall have a minimum of 5 years' experience in invertors and shall have a minimum 4 years' experience with IGBT transistors used with the drive to produce the output PWM waveform, allowing quiet motor operations.

Adjustable speed invertors shall be a pulse width modulated (PWM) design that has a carrier frequency of 3KHZ or higher so no acoustic noise will be produced onto the motor. The adjustable speed drives shall generate a sine-coded, adjustable voltage/frequency three phase output for complete speed control of a NEMA B VAV duty squirrel cage induction motor. The adjustable speed drive shall maintain a 120% current overload capability for sixty seconds with automatic stall prevention and boost to prevent a nuisance tripping during load or line side transient conditions. The adjustable

speed drives shall maintain a power factor of not less than 0.95 throughout its speed range.

B. Adjustable speed drives shall have the following basic design:

1. Converters shall consist of a modular assembly consisting of diode rectifier and capacitor assembly which will first convert, then filter and maintain a fixed DC voltage source from the fixed voltage and frequency input.
2. Invertors shall use Insulated Gate Biopolar Transistor (IGBT) with a minimum rating of 1000 VDC on 480 VAC controls to invert the converter fixed DC voltage into a sine-coded pulse width modulated output.
3. Control logic shall consist of a single printed circuit board for the horsepower sizes and incorporate an 8 bit or larger, microcomputer central processing unit to control inverter, converter, base drive and external interface functions.
4. Terminal strip for input and output signals must be provided.
5. Drive to be mounted in the high voltage control panel.

C. Adjustable speed drives to include, as a minimum, the following design features as standard:

1. 3KHz or higher sine-coded, pulse width modulated output
2. Eight-bit microcomputer control logic
3. Maximum and minimum speed adjustment capability
4. Controlled speed range of minimum 20:1
5. Overload capability of 120% for 60 seconds, 110% continuous
6. Process follower 4-20m ADC, 0-5 VDC, 01-10 VDC or 0-135-ohm resistance input
7. Minimum of three selectable output frequency ranges
8. Sixteen selectable volts/hertz patterns
9. A four-segment digital readout displaying frequency, status, percent current, percent voltage and percent response signal
10. Current limiting circuit
11. Coast or ramp to stop
12. Electronic reversing
13. Adjustable acceleration and deceleration
14. Fault indicators
15. Fault contacts
16. The drive shall have an open-collector output signal to indicate when the drive's output is at maximum and minimum speed

D. Adjustable speed drives shall have as a minimum the following protective features:

1. Ground fault protection
2. Thermal motor overload relay
3. Current limit adjustable from 60% - 100%
4. Current limited stall prevention during acceleration, deceleration and run conditions

5. Automatic restart after momentary power loss or over voltage. The drive shall not restart into faults other than over voltage, under voltage, or over current due to acceleration rate set to fast, because other faults, such as over current to blown transistor or a short circuit on the output, could cause damage to the inverter. No restart into ground fault.
6. Start into a rotating motor.
7. Fault indicators shall indicate the following fault conditions. Faults should be displayed by flashing on the LED display on the front panel of the inverter. When a fault occurs, the drive shall have built in diagnostic functions that assist in determining the cause and source of the fault. The drive shall also indicate the level of current and voltage and the frequency at the time of the fault.
  - a. over current while running
  - b. over current on output
  - c. internal short circuit
  - d. overload
  - e. over voltage during deceleration
  - f. over voltage due to power surge
  - h. control function error
  - i. ground fault
8. DC bus discharge indicator. The drive must have a visual indication that is visible with the door closed as to whether hazardous voltage still remains on the DC bus so servicing technicians may avoid exposing themselves to dangerously high voltage.
9. Current limiting DC bus fuses.
10. Isolated operator controls.
11. Phase-to-phase short circuit protection.
12. High speed current limiting fuses before drive.

E. Adjustable speed drives shall have the following adjustments available:

1. Acceleration - 0.1 to 300 seconds.
2. Deceleration - 0.1 to 300 seconds.
3. Volts/hertz adjustments.
4. Maximum frequency range.
5. Minimum frequency (0 to 100% speed).
6. Maximum frequency (0 to 100% speed).
7. Carrier frequency (3KHZ to 16KHZ).
8. Bias and gain adjustment for 4-20mA, 0-5VDC, 0-10VDC follower.  
(Can be direct or indirect acting).

F. Adjustable speed drives shall be designed to operate within the following environmental and service conditions:

1. Ambient service temperature: -10 C to 40 C
2. Ambient storage temperature: -20 C to 60 C
3. Humidity: non-condensing to 90%.
4. Altitude to 3300 feet.
5. Service factor: 1.1.

6. Input voltage: 380/480VAC +/- 10% for 480VAC series.
7. Input frequency: 50/60 hertz +/- 3%.

G. Adjustable speed drives shall be subject to the following parameters and tests:

Integrated circuits (TTL) and components used for circuit board construction shall be tested to an acceptance criterion of 0.5% AQL (Accepted Quality Level).

In-circuit testing of printed circuit boards shall be conducted to insure proper mounting and correct value for the components.

Final printed circuit board assemblies shall be functionally tested via computerized test equipment where tests and acceptance criteria are pre-programmed and test results are stored as detailed quality assurance data.

Fully assembled controls shall be combined-tested for performance and functionality at the Manufacturer's factory with fully loaded VAC rated induction motors. The combined test data shall then be analyzed to insure adherence to quality assurance specifications.

H. Adjustable speed drives shall be designed and built to the following standards:

1. UL Listed
2. NEMA listed
3. IEEE 587

I. Adjustable speed drives shall be provided with a set of reverse contactors for connection of a two-position key switch in the pump station control panel door to safely transfer the motors from line, or from line to drive at zero speed.

J. Invertors may be programmed locally from a standard front mounted programming panel or through a serial communication port.

K. Variable frequency drives shall have an internal DC link choke to prevent electrical noise from the drive to power source.

L. Invertor Manufacturer shall have the following available:

1. Service engineer
2. Training/Service schools
3. 24-hour phone service

M.. One drive shall be installed for the turbine pumps. Pressure maintenance pump shall also include a drive.

N. Drive Manufacturer shall be ABB 500 Series, Allen Bradley, Danfoss, Altivar 61 Series or approved equal.

## 2.07 RELEASE VALVE

- A. A pressure release valve shall be installed downstream of the pump station turbine pumps. The valve is to relieve pressure in excess of system pressure and is to protect the irrigation system against surge on closing.

The valve shall seal by means of a corrosion-resistant seat and resilient, rectangular seat disc. These and other parts shall be replaceable in the field; such service and adjustments to be possible without removing the valve from the line. The stem of the valve shall be guided top and bottom by integral bushings. The control valve and its pilot control system shall contain no packing glands or stuffing boxes. The diaphragm shall not be used as a seating surface nor shall pistons be used as an operating medium. Internal and external ferrous surfaces shall be coated with a high-quality, two-part epoxy primer; the exterior to then receive a coat of baked enamel paint.

The valve, with appropriate pilot valve in place, shall be operationally and hydrostatically tested prior to shipping and shall carry a one-year warranty against failure due to defects in workmanship or materials. Release valve to be flanged, minimum 150# cast iron.

Valve shall be sized for full discharge capacity of pump station, intermittent service, 3-inch.

- B. Ball valves and flow strainers shall be installed on copper tubing for filtering and isolation of CRL's, etc.
- C. Discharge from the release valve shall be piped to the edge of the pump station skid and out the enclosure to a 4-inch HDPE discharge pipe through a painted steel return line. Discharge may be incorporated with the wye strainer discharge.
- D. Pressure release valve shall be as manufactured by Cla-Val or approved equal.

## 2.08 CHECK VALVES

- A. Check valves to be flanged, 150# rated, center pivot, spring loaded, non-slam, silent type cast iron check valves. Sealing surfaces shall have resilient Buna-N-Rubber as manufactured by Val-Matic or approved equal. Pressure loss is not to exceed 3 psi at full discharge capacity. Check valve shall be mounted directly to discharge header. Butterfly, ball or swing type check valves shall not be approved for installation including for the pressure maintenance pump.
- B. Pressure maintenance pump shall include a skid mounted check valve in addition to the one included in the pump.

## 2.09 ISOLATION VALVES

- A. Isolation valves shall be installed on individual pump discharges, and pump station release valve. Valves shall have lever handle. Latch lock or manual gear operator type butterfly valve shall be installed for release valve isolation. Station isolation valve shall



be gear operated. Pressure rating shall be 200 psi. Trim shall include stainless steel stem, bronze or nickel coated iron streamlined disc, and full faced resilient seats. Butterfly valves to be as manufactured by Victaulic, Watts or approved equal.

## 2.10 FLOW SENSOR

- A. Pump station shall include a flanged magnetic flow sensor having the ability to report the gallons per minute being pumped and the totalized flow volume to the control panel. Magnetic flow sensor must be accurate to within plus or minus 0.25% of full scale. Flow sensor shall be installed according to Manufacturer's recommendations. Flow sensor to be as manufactured by Krohne, Siemens or approved equal.

## 2.11 PRESSURE TRANSDUCER

- A. Pressure transducer shall be utilized for providing pressure signal for the pump control logic. Pressure transducer shall be a solid-state bonded strain gage type with an accuracy of plus/minus 0.25% and constructed of stainless steel. Transducer shall be rated for system discharge pressure and shall provide gauge pressure output, rather than an absolute. Pressure transducer shall be constructed of stainless steel. Pressure transducer shall be 4-20mA analog type with 7- 33 VDC supply range.
- B. Pressure transducer shall have stainless steel diaphragm and 200 psi burst pressure rated for submersible applications. Transducer shall also have built-in surge protection.
- C. Transducer shall have a ¼ inch NPT welded pressure port adapter for installation into water pipe. Transducers shall measure pump discharge pressure and have a range of 0-250 psi gauge.
- D. Pressure transducer shall be as manufactured by Druck, IFM or approved equal.

## 2.12 PIPE AND FITTINGS

- A. Pump station pipe and fittings shall be welded seamless, steel flanged, Gruvlok or Victaulic connected standard steel pipe conforming to ASTM and AWWA Standards and shall be pressure tested to 150% of maximum pump pressures. The pipe shall be sized so that velocities in pipe on the discharge side remain below 15 feet per second. The pipe shall be sized to minimize velocities while keeping the accuracy of the flow sensor at low flows. Welded joints are to be welded by a certified welder and to conform to ASTM Specification A234 (no threaded joints will be accepted). Flanged joints to be Class 150 forged steel flanges, unless otherwise specified. Pipe is to be independently supported and shall not exert a strain on pump, valves or other fittings.
- B. Pipe for pressure maintenance pump shall be minimum 2-inch, Schedule 40 steel.
- C. Irrigation dogleg fitting shall be 6-inch x 10-inch, welded seamless standard steel pipe for flange connection to 10-inch HDPE irrigation mainline by the installing Contractor.
- D. Release valve/wye strainer dogleg fitting shall be 3-inch x 4-inch, welded seamless standard steel pipe for flanged connection to 4-inch HDPE discharge pipe by the

installing Contractor.

- E. Pipe shall be painted welded steel or stainless-steel. No galvanized pipe shall be allowed on the pump station.
- F. Pipe shall be epoxy coated, inside and outside.

#### 2.13 WYE STRAINER

- A. An iron body flanged wye type strainer having a working pressure of 200 psi shall be part of the pumping station. The screen in the strainer shall be made from AIAI 304 perforated stainless steel reinforced for liquid service, with 1/16-inch screen. The strainer shall have a bolted cover flange machined to securely receive the screen, and the screen shall be positively secured in both the body and cover flange. The strainer should be sized so that "the clean" pressure drop is no more than 3.0 psi as manufactured by Watts Regulator or approved equal.
- B. Provide a 2-inch manual ball valve for wye strainer release.
- C. Discharge from the wye strainer shall be piped to the edge of the pump station skid and out of the building enclosure to a 4-inch HDPE discharge pipe through a painted steel return line. Discharge may be incorporated with the release valve discharge.

#### 2.14 DRAINS

- A. 1/4-inch ball valves are to be used as drains at low point in the station. Pipe water from drains to wet well through firmly secured flexible Type L copper tubing.

#### 2.15 GAUGES

- A. Pressure gauges on the station shall be of the same size and scale, 0-200 psi or as required. Gauges shall be glycerin filled with an accuracy conforming to ANSI Grade B or greater. Gauges shall be provided minimum before the release valve and on the discharge line downstream of the release valve. Pressure gauges shall be installed on test cocks or ball valves to facilitate servicing.

#### 2.17 HIGH VOLTAGE CONTROL PANEL

- A. Enclosure to be NEMA 4, 12-gauge steel minimum. The panel as a unit shall be UL Listed. Units constructed of UL components in lieu of UL Listing shall not be accepted. Door gasket seals shall be close-cell neoprene sufficient to protect interior components from weather and dust. Electrical panel doors shall be constructed of 12-gauge steel with locking screws and latches. Internal components of the enclosure shall be mounted on removable back panels. Mounting screws for the components shall not be tapped into the panel enclosure. Panel penetrations must maintain NEMA 4 integrity. Wiring within and interconnecting the panels and pumps shall be complete. Wiring troughs and cable

raceways shall be self-contained within the enclosures and no external cable trays or wiring troughs will be permitted.

Circuit breakers shall be fast acting, low peak, current limiting action and shall have interrupting capacity (A.I.C.) as required for motor horsepower per the National Electrical Code.

- B. A drive bypass feature shall be installed in the panel to operate the turbine pumps if drive failure occurs. The bypass's shall contain solid state reduced voltage starters and reversing contactors. Appropriate controls and starters for this purpose shall be installed in the high voltage control panel for the turbine pumps as well as for starting the lay pump. Starters shall be Allen-Bradley or approved equal. The VFD/starter system shall follow the following logic:
  - 1. Normal Operation: Pressure maintenance pump VFD shall start on a drop-in pressure. First turbine shall start on the VFD. Second turbine shall start on the pumps across the line and the VFD shall ramp down.
  - 2. Loss of VFD Operation: Pressure maintenance pump shall start on a drop-in pressure. At required flow/pressure, 1st turbine shall start on the pumps across the line starter. Second turbine shall start on the across the line starter.
  - 3. As such the pressure maintenance pump shall have a VFD and an across the line starter. The turbine pumps shall have one (1) VFD drive and two (2) across the line starters.
- C. An air to water heat exchanger unit shall be installed on one side or back of the panel. The forced water heat exchanger is responsible for maintaining good working temperatures within the panel. The heat exchanger shall be installed on its own electrical circuit breaker included in the high voltage control panel.
- D. Across the line starters shall be protected on each power leg by a time delay fuse of the needed amperage and have a reset button. Motor starter coil shall be 120 volt operated. Overload relays shall be ambient-compensating, differential-tripping type installed on each power leg and shall be set to trip at 105% of motor full load current rating. Starters shall be horsepower rated and conform to the standards and recommended practices of NEMA as manufactured by Allen Bradley or approved equal.
- E. High voltage control panel shall include windows to view the drives digital readouts through the doors. Maintain NEMA integrity. Drive interface shall be installed internal to the control panel enclosure.

## 2.18 MAIN STATION DISCONNECT

- A. A three-pole approved type fused disconnect (200 amps) shall be mounted in the high voltage control panel to completely isolate the electrical system from the incoming power. The disconnect shall conform to NEC requirements. The station disconnect shall have an operating handle on the front or side of the panel. Rotary handles shall include

actuator supports to enhance alignment.

- B. Station shall also have a separate outdoor mounted disconnect provided on the enclosure to turn off electric power to the pump station and enclosure. Disconnect shall be NEMA 4 rated and include two 6-inch x 8-inch “DANGER: HIGH VOLTAGE” signs.

## 2.19 CONTROL/DISPLAY PANEL

- A. Panel shall be NEMA 4 separate or combined with the high voltage panel in accordance with NEC and not less than 12-gauge steel and equipped with an-impact-resistant, gasketed door. The door shall have a draw-tight locking screw latch. The incoming power shall be isolated by means of a circuit breaker or fused disconnect. The entire pump station control panel and the manner in which it is installed shall be UL Listed.
- B. Pump sequence controller shall be industrial grade multi-function-micro-processor, field programmable, and equipped with light emitting diodes for diagnostic and monitoring purposes. It shall be capable of operating at temperatures of 0 to 70 degrees Celsius (32 to 150 degrees Fahrenheit). The microprocessor shall integrate to the other hardware items through optically isolated input/output modules. The programming shall be stored in EEPROM memory. It shall have a minimum of 128K of battery backed RAM to store pump station operation history. For optimum viewing it shall incorporate a bright touch screen display. The data entry shall be through an environmentally sealed touch screen. The controller shall receive inputs from flow the sensor and pressure transducer located on the discharge manifold capable of providing controlled time sequence station start-up, starting and retiring pumps through the use of the flow sensor, pressure transducer and variable frequency drives.
- C. Panel shall meet NEC, Ohio and Mentor Codes. In the event of a conflict among the codes, the current National Electric Code shall predominate provided it meets minimum local standards.
- D. Provide a disconnect switch in motor circuitry for easy isolation of each motor and its circuit breaker. Motor disconnect switches shall be circuit breaker, rotary handle or other approved type. "ON-OFF" indications shall be provided on the disconnect switches themselves. Rotary handles shall include actuator supports to enhance alignment. Disconnects may be exterior or interior to the panels.
- E. Each pump shall have an HOA switch with position indicator mounted in the control panel door or incorporated in the touch screen display.
- F. When the touch screen is lit, it should indicate that power is available to the control power circuitry.
- G. Each pump motor is to have an elapsed time hour meter mounted in the control panel door in addition to those incorporated into the touch screen display. Meters shall indicate the number of hours and tenths of an hour the motor has been energized since a

predetermined point of time.

- H. A pump running light (green) for each motor is to be installed in the control panel door or incorporated in the touch screen display. The pump run light is to be illuminated whenever the associated pump motor is drawing electrical current. This light may be integrated as part of the HOA switch.
- I. A phase-failure/drive failure light shall be installed in the control panel door or incorporated in the touch screen display. The incoming power to each motor (unless included in the starters) as well as the panel shall be protected by a phase-failure/low voltage system dropout relay to de-energize the pump station in case either phase failure, reversal or low voltage condition occurs. The phase-failure cutout condition will remain in effect after power is restored with the indicator light to remain illuminated until manually reset.
- J. A low discharge pressure light/reset button is to be installed in the control panel door or incorporated in the touch screen display. The light is to illuminate whenever the station shuts down from a pressure drop below a preset level. A low pressure reset button in the panel door or incorporated in the touch screen display must be depressed in order to re-energize the entire station. Low discharge pressure is to be sensed by the pump starting set point. When the station discharge pressure decreases to this point and maintains a start signal for the time called out, the pumps will be de-energized and remain so until the circuit is manually reset. Panel shall have a manual override for this circuit located on the panel door or incorporated in the touch screen display, allowing pumps to operate at low pressure to fill irrigation lines.
- K. The control panel shall include a circuit breaker on the incoming line such that only one terminal screw is energized in the entire panel when the circuit is open.
- L. Control voltage shall be 120 VAC or 24 VAC and be supplied from a transformer dedicated to the control circuitry only. Control voltage transformer shall not provide power to other devices. Control voltage transformer shall have over current protection in the form of a circuit breaker on the primary and secondary side.
- M. Individual digital LED flow and discharge pressure displays shall be incorporated as part of the touch screen displays.
- N. Time-delay relay switches used in the control panel shall be 8-pin, 3-range, field adjustable switches with integral OFF, RUN, ON indicator light. Each time-delay relay shall be independently wired to the appropriate mode of operation.
- O. A double-pole, single-throw, switch is to be installed in the control circuit to override cut-out circuits.
- P. Corrosion-inhibiting modules shall be installed in electrical enclosures in accordance with the manufacture's recommendations.

- Q. A low water level cutout indicator lamp shall be mounted in the front control panel door or incorporated as part of the touch screen display to shut the pumping station down if the water level drops below a preset level in the wet well. Pump station shall not operate until the safety circuit has been manually reset.
- R. Gauges and switch gauges shall be isolated from electrical switch gear and control panels. Gauges shall be wired to the panel using waterproof connections. Equipment and wiring shall be labeled and mounted so that maintenance and adjustments can easily be performed from the front of the panel. Gauges shall be liquid filled. Controls shall be assembled from standard industrial logic components.
- S. Station shall have a high-discharge pressure safety circuit that will shut down the pumping station if discharge pressure reaches a predetermined high level on either discharge pipe. Indicating light shall be mounted in the control panel door or incorporated as part of the touch screen display. Pump station shall not operate until safety circuit has been manually reset.
- T. A key lock switch shall be mounted on the panel or a password protected code in the touch screen software to indicate a monitor or modify status to the programmed data set points.
- U. A two-position switch mounted on the panel door to safely transfer the motor from line, or from line to drive, at zero speed shall be interconnected to a reverse set of contactors in the motor drive.
- V. Control panel shall include a door panel mounted potentiometer or adjustable slide switch in the touch screen display for adjustment of the drive speed when filling the system or running the station under a manual condition.
- W. An automatic/manual, lead/lag, alternation switch shall be mounted in the control panel door or incorporated into the touch screen display. The switch will allow the turbine pumps on the station to run with automatic alternation or the lead pump can be manually selected.
- X. Manufacturer shall provide one of each size and type of fuses included in the pump control panels.
- Y. In conjunction with the wet well level indicator the station software shall include a well/pond level control management system capable of managing the pond level. System shall control the operation of up to two devices through remote relays in the control panel. Panel shall include an indicator light on the door or incorporated in the touch screen display that shall illuminate whenever the level indicator is calling for water. There should be a manual override switch for operation of the relays built into the touch screen display.

Z. Control panel shall include RS-232 and RS-485 communication ports and two (2) analog input modules for interfacing of the control panel with the monitoring software. The communication between the pump control panel and other devices shall be over a wireless connection.

AA. In conjunction with the pump station operation, the control panel shall have the ability to activate external indicator lights (supplied and installed by the pump station Manufacturer) on the exterior to the pump station enclosure. Lights signals shall be as follows:

1. Green – flows exceeding 35 gallons per minute
2. Red – fault

Lights shall be powered from the control panel and shall be 120-volt, approximately 15 watts each.

#### 2.4 OPTICAL ISOLATOR

A. Pump station Manufacturer shall supply within the electrical control enclosure an electronic signal optical isolator. The optical isolator shall allow additional monitoring of the pumping station flow signal. This signal may be utilized by the irrigation control system and any additional system that may require a flow signal to operate. Optical isolator shall be as manufactured by Data Industrial or approved equal.

B. Pump station Manufacturer shall include dry contact relays with terminal strip wiring points to allow the activation of auxiliary equipment. The dry contacts shall close during the automatic operation of any pump, not including pumps utilized for pressure maintenance purposes.

#### 2.20 MONITORING SOFTWARE WITH SMART PHONE APP

A. Pump station control system shall incorporate a cellular modem for remote monitoring of the control system that is accessible from a web enabled device via the internet.

B. Web enabled device for remote monitoring and control of the pump system shall require a browser.

C. Historic data specific to each RTU shall be stored in a password protected secure data storage facility. The secure data storage facility shall be environmentally hardened, secure of viruses and power anomalies.

D. Remote monitoring and control system shall be accessed by a secure login and password. A user hierarchy shall provide varying levels of access as defined by the system administrator. Upon successful login, the user shall be able to monitor the complete pump station on a single overview screen. Additional pump monitoring and control features shall be accessed through links from the overview screen. Specific features of this system shall include, but not be limited to:

1. Graphical overview of system operations and status including pump status, flow, pressures, power draws, and regulate set points and alarms.
  2. Operational status of pumps: Enabled/Disabled, Running/Not Running, Position of Hand/Off/Auto switch.
  3. Controls/software shall have the capability of being monitored through the touch pad or being remotely monitored through the use of an internet connection to a smart device.
- E. The software shall be capable of:
1. Monitoring Pump Station Status (on/off, current flow, pressure, total usage and alarms)
  2. Stop/Restart Pumps
  3. Reset/Acknowledge Alarms
  4. Display Pressure/Flow Graph
  5. Display Pump Running Graph
  6. Display Usage Graph
  7. Display Maintenance Requirements
  8. Change System Clock
  9. Automatic Lockout of pump during specific time periods.
- F. Smart phone application shall be available to the user to remotely monitor and receive alerts for the pump station via a connected iPhone or approved equal. Other smart phones that the user may use shall include browser capability which allows the user to log into the web site to view his data.
- G. Alerts shall be programmed to be received via text messages, regardless of smart phone Manufacturer.
- H. Help portal shall be available on the web system, which the user can use to seek advice on issues regarding operation of the system, once logged in.
- I. User rule writing capability on web based system enabling the ability to define actions which the user wants automatically executed when data from devices meet the criteria defined by the rule being written. This capability shall allow the user to set limits and alerts using the device installed on the pump station via:
1. Multiple rules that are allowed to be written on the same device.
  2. Rules that have more than one criteria.
  3. Multiple alerts that are capable on the same device
- J. Software will be responsible for recording minimum the past 7 day's history of the pump station operation. It shall record a value or the average flow, pressure and pumps on/off state every minute and store this in memory for the past seven days. It shall then have the ability to communicate this history to a remote computer where it can be in different periods (1, 12, 24 hours or 7 days at a time).



1. Cellular (GSM or CDMA) shall include 5 years of cellular service with unlimited data. Pump station Manufacturer to supply hardware and cellular service.
2. Monitoring software shall have the ability to directly interface with the Rain Bird Cirrus Pro or Toro Lynx CE central control software, latest versions.

#### 2.21 SECONDARY CONTROL CIRCUITS/FUSES

- A. Circuit breakers with appropriate ratings shall supply power to drive and pump starter coil circuits, the control system and to other circuits as specified. Fuse holders shall be safety style so that operator can remove without danger.

#### 2.22 WIRING

- A. Pump station wiring from the control panel to the motors shall be in conduit with copper conductors rated not less than 600 VAC and of proper size to carry the full load amperage of the motors without exceeding 70% capacity of the conductor. A grounding cable sized to current National Electric Code requirements shall be included in the liquid-tight conduit. There shall be no splices between the pump station motor starters and the motor connection boxes.
- B. Wiring to flow sensor and pressure transducer shall be multi-conductor shielded cable suitable for Class II low voltage controls.
- C. Wiring within starter/VFD and control panels and between control or starter/VFD panel and components of the pumping station shall be completed by the Manufacturer.

#### 2.23 LIGHTNING PROTECTION

- A. Electrical equipment shall be protected against lightning and voltage surges by a Category C and Category B surge arrester to suppress voltages on the incoming power. Response time shall be less than 5 nanoseconds. Pass voltage for a 480-volt device to the end equipment shall not exceed 1500-1800v when subject to 8ms-20ms wave shape resulting in a performance of 3,720 joules minimum with a power dissipation of 82,500 joules @ 1800v maximum pass voltage to equipment. Arrester shall meet IEEE Standard No. 28 Discharge Voltage Test and withstand a maximum discharge current of 60,000 amps.

#### 2.26 SEQUENCE OF OPERATION

- A. Pressure maintenance pump VFD shall start on predetermined drop in pressure for demands less than approximately 50 gallons per minute. Variable speed pump #1 shall start on flow. Motor frequency shall vary to provide required station demand in gallons per minute at a constant pressure until demand is met or exceeds the pump capacity. Drive shall then transfer to pump #2 as a variable speed. Motor frequency shall vary to

provide the required station demand in gallons per minute at a constant pressure until demand meets or exceeds the #1 and #2 pump capacities. Pumps shall retire in the reverse order. Pressure maintenance pump shall be locked out of station operation following initial sequencing, but shall return to service on shut-down if required for low flows.

- B. Pressure maintenance pump shall be used to maintain system pressure at zero flow.
- C. Pump station shall be capable of providing flows of 0 to approximately 1,000 gallons per minute at 115 psi discharge pressure as required by the irrigation system demand.

## 2.27 LIQUID LEVEL SENSOR

- A. Ultrasonic liquid level sensor shall be provided with enough manufacturer supplied cable to connect directly into the control panel PLC. Sensor transmitter shall provide a 4-20mA signal, which shall be read by pump station programmable logic controller (PLC). Accuracy shall be +/- 0.3% minimum over full-scale range (21-foot water column).
- B. Transmitter shall be installed with a stilling tube to prevent turbulence at the water surface as read by the transmitter. Stilling tube shall be 4-inch PVC or approved equal.
- C. Sensor shall be manufactured by Flowline, Model LU81-5101 or approved equal.
- D. Wet well liquid level control safety float shall be rated for 32-190 degrees. Float shall be constructed of ABS and be leak proof, shock proof and impact resistant. Float shall be normally open. Float shall be as manufactured by Conery Manufacturing or approved equal.
- E. Level controls shall be fully integrated with the control system with programmable set points accessible through the station touch screen.

## 2.28 RELAYS

- A. Relays shall be normally open, 120-volt contactor, rated 10 amps. Relays shall be NRU series with LED indicator and 4.7K to 100K sensitivity. Relays shall be installed in a NEMA 4 enclosure housings and shall be mounted on the top left side of the pump station control panel located in the pump house.

## 2.29 PAINTING

- A. Painting of the entire pump station including the underside of the skid shall consist of a multi-step coating system, which includes metal preparation, and a two-part polyurethane finish having a total dry film thickness of not less than 5 mils. Metal surfaces shall be sandblasted to bright metal prior to painting. Paint shall be ultraviolet insensitive.
- B. Pipes shall be epoxy coated inside and out. Coating shall be a one part thermosetting

epoxy coating, NSF-61 certified, 3M Scotchkote 134 or equal.

### 2.30 MISCELLANEOUS

- A. Provide a 150# rated 2-inch thread-o-let with 2-inch nipples, 2-inch 600 WOG ball valve and 2-inch threaded plug downstream of the pump and release valve for attachment of an air compressor line to facilitate winterization of the system.
- B. Provide three (3) 150# rated 3/4-inch thread-o-lets with 3/4-inch threaded plugs in the pump station downstream of the pump and release valve for attachment of a fertigation system injection assemblies on the discharge pipe. Thread-o-lets shall be positioned as follows:
  - 1. 1 at top-dead center 12:00
  - 2. 1 at 3:00
  - 3. 1 at 9:00

### 2.31 DOGLEG FITTINGS

- A. Irrigation dogleg fitting exiting the pump station shall be welded, seamless steel. Dogleg fitting shall be flange connected to pump station discharge by others. Dogleg fitting shall be flange connected to new 120-inch HDPE mainline. Dogleg fitting shall be 6-inch x 10-inch x 4 feet in length.
- B. Release valve/wye strainer dogleg fitting exiting the pump station shall be welded, seamless steel. Dogleg fitting shall be flange connected to pump station by others. Dogleg fitting shall be flanged end connected to new 4-inch HDPE pipe. Dogleg fittings shall be 3-inch x 4-inch x 4 feet in length.
- C. Dogleg fittings shall include two 90-degree elbows. 45-degree elbows shall not be approved for dogleg fittings.

### 2.32 LAGGING EQUIPMENT

- A. Provide 8-5/8-inch stainless steel bolts 8 inches long and 8-4-inch x 8 inch, 1/4-inch-thick stainless-steel anchor brackets supplied by the Manufacturer.

### 2.33 INLET STRAINER

- A. Inlet strainer shall be 32-inch square box type with minimum 3,072 square inches of screened area. Mesh to be 1/2 inch x 1/2 inch stainless steel screen installed on three sides. Top and bottom to be solid stainless-steel panels (minimum 20 gauge). Strainer shall bolt onto a 24-inch SDR 35 inlet pipe.
- B. Inlet strainer shall be provided by the pump station Manufacture and shall be shipped separately, ahead of the pump station.

2.35 ENCLOSURE

- A. Enclosure shall be pre-assembled and weather tight with appurtenances.
- B. Enclosure shall meet the following Codes, Standards and Inspections
  - 1. (OSHA) 29 CFR 1910, “General Industry OSHA Safety and Health Standards.”
  - 2. Manufacturer shall comply with applicable Mentor and Ohio building codes and NEC.
- C. General Requirements
  - 1. Pump station manufacturer shall be responsible for supplying a completed enclosure on skid in accordance to applicable codes and the specifications.
  - 2. Enclosure may be fiberglass, composite or pre-approved equal.
  - 3. Enclosure will be equipped with features, furnishings and other accessories to make a complete and functional unit and shall be completely confined within the skid boundaries as specified.
  - 4. Approval of drawings will be required prior to fabrication.
- D. Minimum Structural Design Requirements
  - 1. Side panels, two sets of double doors and pitched roof panels formed from fiberglass reinforced composite material. This material will be a 32-lb density closed cell fiberglass reinforced polyurethane panel having the following physical properties.

Material Properties	.05”	.75”	1.0”
Tensile Parallel: strength	6,220 psi	4,298 psi	3,837 psi
Tensile Perpendicular: strength	186 psi	274 psi	343 psi
Shear: Strength	530 psi	641 psi	685 psi
Shear: Modulus	3,750 psi	5,376 psi	6,243 psi
Compression: Strength @ 2.5% strain	366 psi	454 psi	339 psi
Compression: Modulus	14,700 psi	18,154 psi	13,627 psi
Flex: Strength	6,813 psi	5,372 psi	5,669psi
Flex: Modulus	311,180 psi	217,520 psi	278,440 psi
Static Bending: Strength	6,813 psi	5,563 psi	6,422 psi
Static Bending: Modulus	378,770 psi	279,310 psi	286,450 psi
R-Value:	1.22F(ft <sup>2</sup> )h/Btu	1.92F(ft <sup>2</sup> )h/Btu	2.24F(ft <sup>2</sup> )h/Btu
Coefficient of Linear Expansion:	1.33 X 10 <sup>-5</sup> in/in/F	1.33 X 10 <sup>-5</sup> in/in/F	1.33 X 10 <sup>-5</sup> in/in/F
Mold/Fungi Test:	Passed Rating of 0	Passed Rating of 0	Passed Rating of 0

- 2. Corner posts, center posts and header beams shall be formed from structural composite profiles of steel having UL 94 VO Flame Resistance Properties. The chart below is a typical listing of mechanical properties of the structural profiles utilized within the composite enclosures.

Mechanical Properties	Unit	Value
Tensile Strength	Psi	12,500
Tensile Modulus	Psi X 10 <sup>6</sup>	1.2
Flexural Strength	Psi	25,000
Flexural Modulus	Psi X 10 <sup>6</sup>	1.1
Compressive Strength – flatwise	Psi	34,000
Compressive Strength – edgewise	Psi	29,500
Shear Strength	Psi	13,000
IZOD Impact Strength	Ft. lb./in	9.6
Water absorption in 24 hrs.	% by weight	.2
Specific Gravity		1.8

3. A header beam shall run from corner post to corner post on all sides of the enclosure. The header beam shall be chemically fused to the corner posts and center posts utilizing a Methacrylate structural adhesive. The composite framework is then attached to the skid utilizing the supplied mechanical hold-downs.
  4. Each side panel shall have either a corner or center post on each side. Corner and center posts hold side panels in place from behind. Header beams hold side panels in place at the top and front.
- E. Entire roof shall be removable without disturbing the remainder of the building. The roof panels shall sit on top of and bolt to the header beams. Bolts shall be spaced no farther than 20” apart around the lower flange of each roof panel. Removal of these bolts shall be the only obstacle to removing the entire roof. Two lifting points will be attached to the roof assembly for ease of removal. When two roof panels are joined together the mated pair is easily removed with a lifting strap and a boom. Removing the roof panels allows full access to pumps and motors from above.
- F. Painting shall consist of a multi-step coating system including composite preparation for use of a two part ultraviolet insensitive Aliphatic Urethane finish having a total dry film thickness of not less than 5 mils. All exposed enclosure components including side panels, doors, roof panels, posts, headers, and mounting brackets shall be painted beige or approved equal.
- G. Pump station manufacturer shall provide a Fusible Disconnect Mounted to the Outside of the Composite Enclosure.
- H. Enclosure shall be designed to withstand wind load of 80 MPH and a roof live load of 42 PSF. Maximum loads shall be 130 MPH for the wind load and 110 PSF for the snow load.
- I. Electrical
1. LED lights shall be installed to deliver optimum light, controlled by an inside switch.
  2. Manufacturer shall identify electric cable and wire in pull boxes by means of an engraved phenolic tag, indicating equipment served and voltage. Tags shall be

- color coded for various voltages and shall be no less than 1-1/4 inch by 1/8 inch thick with 5/32 inch hole. Tags shall be fastened to cable with nylon cord.
3. Manufacturer shall identify both ends of control wires by sequential numbering or other method approved by the Owner's Representative.
  4. Manufacturer shall install a 3 phase dry type transformer and four wire distribution panel with circuit breakers mounted inside the enclosure. Manufacturer shall furnish and install conduit from the main power distribution panel to the pump control cabinet and for other electrical devices to be included in the enclosure and as part of the booster pump station.
  5. Flexible liquid-tight conduit shall be used for connections to rotating or vibrating equipment and for short connections where rigid conduit is impractical. Flexible conduit fittings shall be moisture tight by Crouse-Hinds, or approved equal. Flexible conduit shall be American Metal Hose "Sealtite", or approved equal. Steel duct or wire ways shall be used for surface mounted switching where same as in groups. Conduits shall be sufficiently braced or anchored to properly resist displacement. Conduits entering cabinets or boxes shall be secured in place with galvanized locknuts and approved bushings. Conduit ends within cabinets, panels, boxes, etc., shall be completely closed with Johns-Mansville "Duxseal" or approved equal.
  6. Minimum acceptable wire size for power, control and lighting shall be #12 AWG. The neutral and ground wires shall have a white and green outer braid respectively, throughout the system. Conductors shall be tinned copper, free from splints, flaws and other defects. National Electric Code Type THW or THHN, 600 volt insulation shall be used for lighting and power wire.
  7. Wall switches shall be located on the enclosure wall beside the door. Where two or more switches are located at the same point, they shall be gang-mounted with gang plates. Switches shall be specification grade with quiet mechanism, 20 ampere, rated at 120 volt.
  8. Two (2) grounded (GFI) duplex receptacles shall be included in the enclosure, one on each of the long side walls. Receptacles shall be mounted with ground lug on top. Receptacles shall come with wrap-around bridge. Duplex receptacle 20 ampere, 120 volt, 3-wire, grounding, Hubbell Cat. #5362-1, or equivalent.
  9. Provide wall plates for each switch receptacle and special purpose outlet. Plates to meet Federal Specification W-P455a. Plates shall be by Hubbell, or approved equivalent.
  10. Provide for each wall outlet, standard outlet boxes. Boxes and covers shall be not less than 1/16 inch thick and in every instance of such form and dimensions to be adapted to its specific use and location, type of fixture to be used, number, size and arrangement of conduits connecting therein. Outlet boxes shall be firmly anchored in place. Junction boxes shall be provided with blank covers.
  11. Enclosure shall include external read and green indicator lights exterior to the enclosure as specified.

#### G. Environmental Control Systems

1. A fan shall be incorporated into one fixed side panel. The fan motor shaft shall be

placed at least 48” above the top of the pump station skid. The fan shall have protective screening completely surrounding the blades and self-opening shutters on the outside of the panel. The fan shall be at least 18” in diameter and move at least 250 cfm. The fan shall draw air from within the enclosure. A self-opening louvered panel shall be placed in a fixed side panel as far from the fan as possible. This louvered panel shall serve as air intake into the enclosure. An industrial thermostat will activate the fan.

2. The manufacturer shall provide a heavy duty industrial rated 5 KW heater. The heater shall be provided with an internal protected disconnect switch, thermostat, and thermal safety overload shutdown. The heater shall be prewired and securely mounted in one corner of the enclosure.

### PART 3 - EXECUTION

#### 3.01 GENERAL

- A. Examine documents applying to this Section noting discrepancies and bringing the same to the attention of the Owner’s Representative for timely resolution.

#### 3.02 PUMP STATION INSTALLATION

- A. Pump station shall be installed on a new concrete pad provided by the installing Contractor. Coordinate installation schedule with the Owner’s Representative and installing Contractor.
- B. Pump skid shall be lagged to concrete pad using 8-5/8-inch stainless steel bolts 8 inches long and 1/4-inch-thick stainless-steel anchor brackets supplied by the Manufacturer.
- C. Dogleg fittings shall be connected without strain to flanged outlets of pump station using flanged connections.
- D. Manufacturer shall be responsible for wiring off skid communications into the panel. Manufacturer shall wire relays for make-up water fill lines to new pump station control panel.
- E. Pipe within the enclosure shall be completed by the Manufacturer.

#### 3.03 MONITORING SOFTWARE INSTALLATION

- A. Manufacture in conjunction with the installing Contractor shall be responsible for loading/integrating/troubleshooting irrigation monitoring software on the irrigation central computer in the maintenance facility office.
- B. Install modems, wiring, connections, software, antenna, etc. as required for proper operation of the monitoring software.

3.04 TESTING

A. Technical start-up of the station:

When the discharge pipe and electrical connections have been completed for the pump station, a factory service representative from the Manufacturer's factory shall be on hand at the site for a period of two (2), one half-day visits. The following services shall be performed by the Manufacturer at no further cost to the City of Mentor during this visit:

1. Start-up pump station and pressurize irrigation system.
2. Manufacturer will conduct training (4 hours minimum) to familiarize the operator(s) with the station operation, maintenance and adjustments, and the monitoring software.
3. Adjust valves and pumps on/off pressures and flows for optimum performance of the irrigation system and to prevent frequent on/off cycling of the pumps.
4. Adjust control panel for optimum pump station performance and efficiency.
5. Adjust high-pressure cut-out so that if the pressure of the system rises above a preset psi the pump station will shut down.
6. Monitor a partial cycle of the irrigation system if possible and authorized by the Owner's Representative to identify problems with the pump station.

B. Testing:

1. Pumps shall operate without undue vibration throughout the range of operating conditions. Pumps and pump station shall be given a running test of normal start, stop and ramping operations under load. During such tests, the pumps shall demonstrate their ability to operate without undue vibration and shall demonstrate without question their general fitness for service. Defects shall be corrected and adjustments made without expense to the City of Mentor. Tests shall be repeated until satisfactory results are obtained. In addition, the pump station shall show that the safeties incorporated in the station are also functioning.
2. Owner's Representative/installing Contractor will notify Manufacturer in advance of final test.
3. Test lines in pump station under pressure for leaks. Repair leaks, retest and repaint.
4. Furnish necessary equipment to perform tests.
5. Test safety features to insure their proper operation.
6. Review Maintenance and Operating Manuals section by section with golf course personnel.
7. Test monitoring software.

3.05 OPERATION AND ACCEPTANCE BY THE CITY OF MENTOR

- A. Upon completion of the work and acceptance by the City of Mentor, the Manufacturer shall be responsible for the training of the golf course superintendent and his assistants in the operation of the station including setting up and completion of pump set points.



Manufacturer shall furnish, in addition to the pump station schematic and Maintenance and Operating Manuals, copies of available specification sheets and parts lists to the Owner's Representative.

- B. Pump station Manufacturer shall guarantee parts and labor as specified.

END OF SECTION

BID FORM

---

(Name)

---

(Address)

---

(City and State)

(Phone)

(Fax)

To furnish, deliver and start-up a totally enclosed 3 pump prefabricated golf course irrigation pump station in accordance with the Bid Documents for the Black Brook Golf Course, being located in Mentor Ohio.

TO: Finance Department  
City of Mentor  
120 Perkins Road  
Mentor, Ohio 44060

To Whom It May Concern:

The undersigned bidder has carefully examined the Bid Documents and also the site of the work and will provide necessary labor, machinery, equipment, tools, apparatus, and other means of construction, and do the work and furnish materials and services called for by the Bid Documents in the manner prescribed therein, and in accordance with the requirements of The City of Mentor under them, for the lump sum price for base bid enclosed.

The undersigned bidder agrees:

FIRST: To begin work with receipt of a purchase order and to diligently prosecute said work in such a manner as to complete work in the Bid Documents in a timely manner. Contractor shall adhere to the established timetable.

SECOND: The undersigned bidder acknowledges the receipt of the following Addenda:

Addendum Number.

- |    |       |             |
|----|-------|-------------|
| 1. | _____ | Dated _____ |
| 2. | _____ | Dated _____ |

(If an individual, partnership, or non-incorporated organization.)

Signature of Bidder: \_\_\_\_\_

By: \_\_\_\_\_

Address of Bidder: \_\_\_\_\_

Business Address: \_\_\_\_\_

**BASE BID I – TOTALLY ENCLOSED 3 PUMP PREFABRICATED PUMP STATION**

To furnish, deliver and start-up the specified totally enclosed 3 pump, prefabricated golf course irrigation pump station in accordance with the Project Documents the lump sum price of:

\_\_\_\_\_ (Dollars)

\$ \_\_\_\_\_  
(in figures)

Delivery (Days after receipt of Purchase Order): \_\_\_\_\_

Terms of Sale: \_\_\_\_\_

Warranty: \_\_\_\_\_

List subcontractors to be used on this project.

Contractor: \_\_\_\_\_ Item: \_\_\_\_\_

Contractor: \_\_\_\_\_ Item: \_\_\_\_\_

PUMP STATION INTAKE PROFILE  
1/4" = 1'-0" (P-1.1)

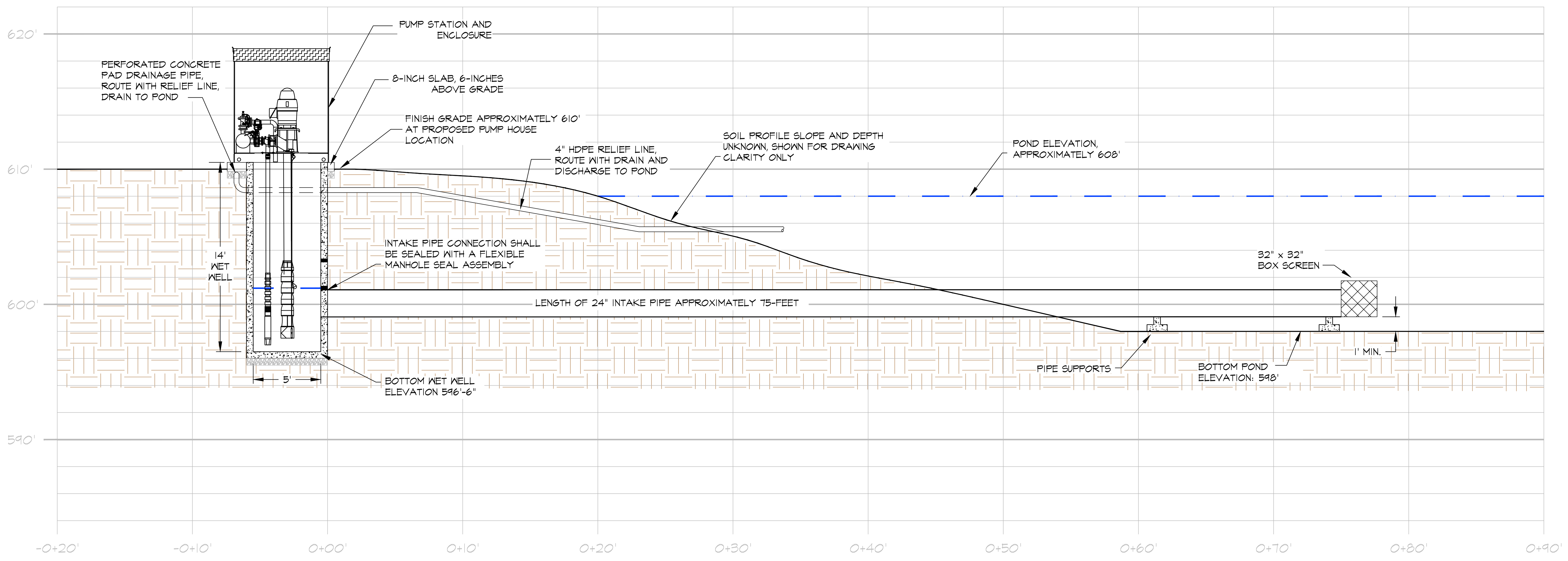

PUMP STATION PLAN VIEW  
1/2" = 1'-0" (P-1.2)

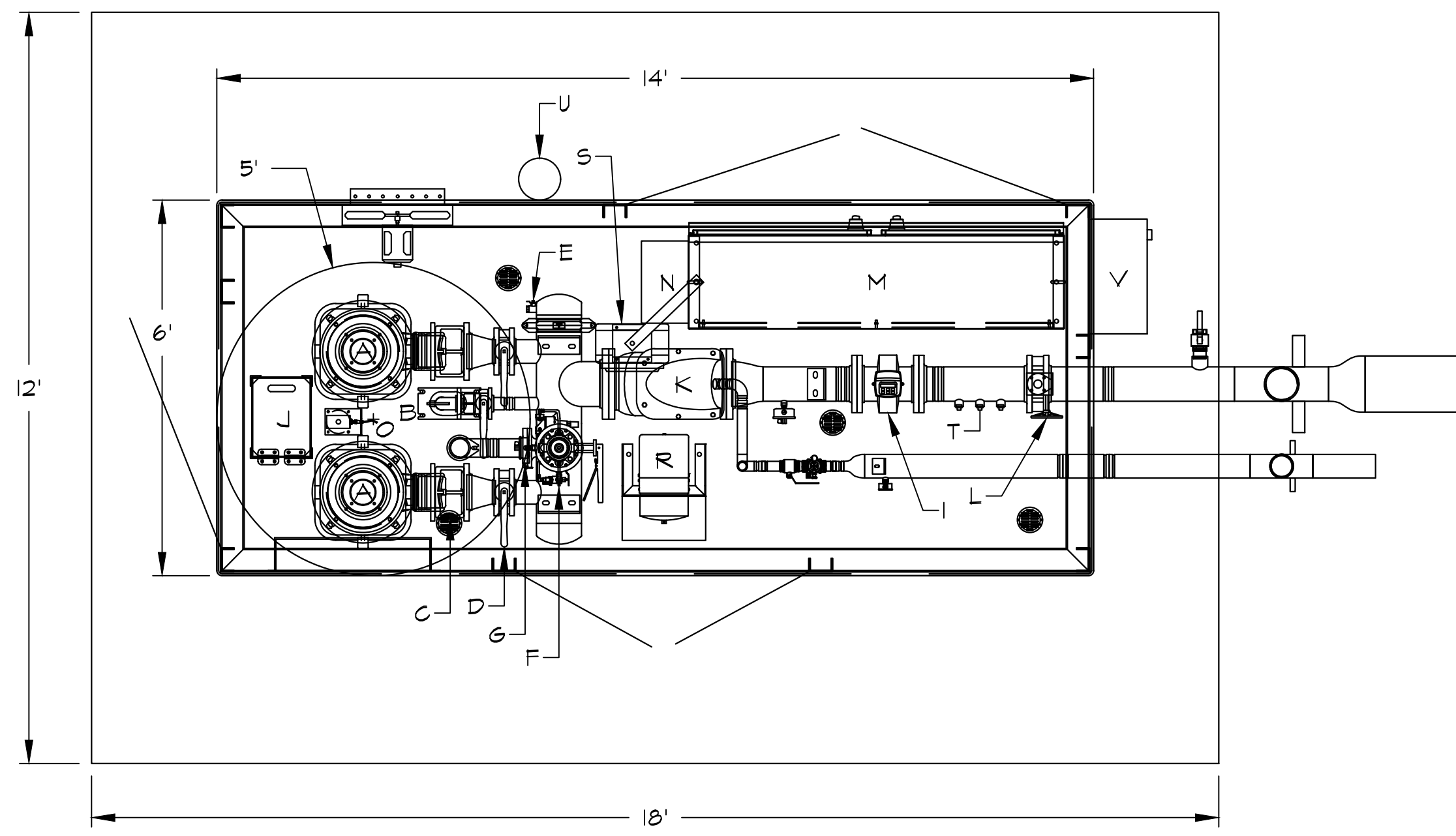

STATION COMPONENTS:

- A 50HP PUMP AND MOTOR
- B 5HP SUSTAIN PUMP AND MOTOR
- C CHECK VALVE
- D PUMP ISOLATION VALVE
- E DRAIN
- F PRESSURE RELIEF VALVE - 3"
- G PRESSURE TRANSDUCER W/ GAUGE
- H PAINTED STEEL BASE (SANDSTONE)
- I ELECTROMAGNETIC FLOW METER - 6" (SIEMENS W/ DISPLAY)
- J NET WELL VIEWING HATCH
- K NYE STRAINER (8") W/ AUTOFLUSH
- L STATION ISOLATION VALVE - 6"
- M CONTROL CABINET - 75X12X18
- N HEAT EXCHANGER, J-BOX UNDERNEATH H/E
- O LEVEL SENSOR W/ 2 POND FILL RELAYS
- P 4" GR X 4" PE X 36" BURY DROP PIPE
- Q 6" GR X 10" PE X 36" BURY DROP PIPE
- R 5KVA TRANSFORMER AND LOAD CENTER
- S 5KW HEATER (CABINET MOUNTED)
- T 3/4" CHEMICAL INJECTION TAPS - QTY. 3
- U TOWN EXTERNAL DUSK TO DAWN LIGHT
- V 200A FUSED EXTERNAL DISCONNECT

PUMP STATION PROFILE VIEW  
1/2" = 1'-0" (P-1.3)

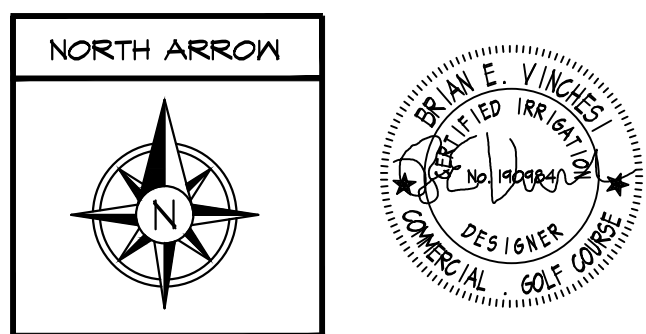
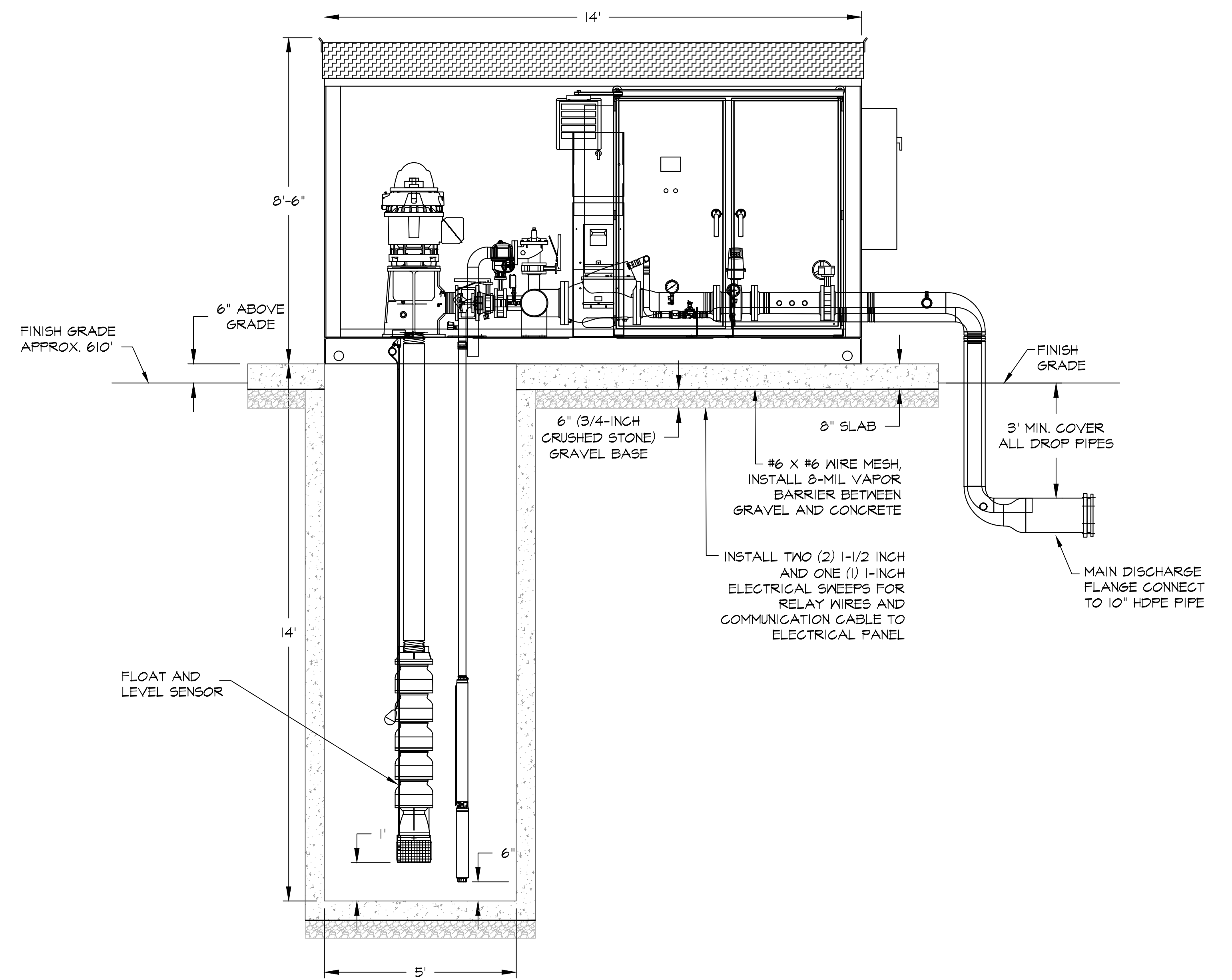

SCALE: AS NOTED	STATUS: FOR BIDDING NOT FOR CONSTRUCTION	REVISIONS: NO. DATE DESCRIPTION	SHEET TITLE: PUMP STATION INTAKE AND COMPONENTS BLACK BROOK GOLF COURSE	PROJECT NAME: BLACK BROOK GOLF COURSE 8900 LAKESHORE BLVD MENTOR, OH 44060	CLIENT NAME: BLACK BROOK GOLF COURSE 8900 LAKESHORE BLVD MENTOR, OH 44060	 20 Merritt Parkway, 2nd Floor Nashua, NH 03062 (603) 425-8412 Fax (603) 425-2166 e-mail: bvn@irrigationconsulting.com 112 S. Old Statesville Road, Suite 104 Huntersville, NC 28078 (704) 843-3688 Fax (704) 843-3581 e-mail: sgr@irrigationconsulting.com
--------------------	--	------------------------------------	--	---	--	---